



⚠ Read this manual carefully before operating this vehicle.

OWNER'S MANUAL

YZF155

YZF155

B1P-F8199-20

 **Read this manual carefully before operating this vehicle. This manual should stay with this vehicle if it is sold.**

Welcome to the Yamaha world of motorcycling!

As the owner of the YZF155, you are benefiting from Yamaha's vast experience and newest technology regarding the design and manufacture of high-quality products, which have earned Yamaha a reputation for dependability.

Please take the time to read this manual thoroughly, so as to enjoy all advantages of your YZF155. The Owner's Manual does not only instruct you in how to operate, inspect and maintain your motorcycle, but also in how to safeguard yourself and others from trouble and injury.

In addition, the many tips given in this manual will help keep your motorcycle in the best possible condition. If you have any further questions, do not hesitate to contact your Yamaha dealer.

The Yamaha team wishes you many safe and pleasant rides. So, remember to put safety first!

Yamaha continually seeks advancements in product design and quality. Therefore, while this manual contains the most current product information available at the time of printing, there may be minor discrepancies between your motorcycle and this manual. If there is any question concerning this manual, please consult a Yamaha dealer.



 **WARNING**

Please read this manual carefully and completely before operating this motorcycle.

Important manual information

EAU10134

Particularly important information is distinguished in this manual by the following notations:

	This is the safety alert symbol. It is used to alert you to potential personal injury hazards. Obey all safety messages that follow this symbol to avoid possible injury or death.
	A WARNING indicates a hazardous situation which, if not avoided, could result in death or serious injury.
	A NOTICE indicates special precautions that must be taken to avoid damage to the vehicle or other property.
TIP	A TIP provides key information to make procedures easier or clearer.

*Product and specifications are subject to change without notice.

EAUE0011

**YZF155
OWNER'S MANUAL
©2019 by India Yamaha Motor Pvt. Ltd.
1st edition, July 2018
All rights reserved.
Any reprinting or unauthorized use
without the written permission of
India Yamaha Motor Pvt. Ltd.
is expressly prohibited.
Printed in India.**

Table of contents

Location of important labels	1-1	For your safety – pre-operation checks	5-1	Tires	7-18
Safety information	2-1	Operation and important riding points	6-1	Cast wheels	7-19
Further safe-riding points	2-5	Starting the engine.....	6-1	Adjusting the clutch lever free play.....	7-20
Description	3-1	Shifting	6-2	Checking the brake lever free play.....	7-21
Left view	3-1	Tips for reducing fuel consumption.....	6-2	Brake light switches	7-21
Right view	3-2	Engine break-in	6-3	Checking the front and rear brake pads	7-22
Controls and instruments	3-3	Parking	6-3	Checking the brake fluid level	7-23
Instrument and control functions ..	4-1	Periodic maintenance and adjustment	7-1	Changing the brake fluid	7-24
Main switch/steering lock.....	4-1	Owner’s tool kit.....	7-1	Drive chain slack.....	7-24
Indicator lights and warning lights.....	4-2	Periodic maintenance chart for the emission control system.....	7-2	Cleaning and lubricating the drive chain.....	7-26
Multi-function meter unit	4-3	General maintenance and lubrication chart.....	7-3	Checking and lubricating the cables.....	7-27
Handlebar switches.....	4-11	Removing and installing the cowling and panels.....	7-7	Checking and lubricating the throttle grip and cable end.....	7-27
Clutch lever	4-12	Checking the spark plug.....	7-9	Checking and lubricating the brake and shift pedals.....	7-27
Shift pedal	4-12	Engine oil and oil filter element	7-10	Checking and lubricating the brake and clutch levers	7-28
Brake lever.....	4-12	Why Yamalube	7-13	Checking and lubricating the sidestand.....	7-29
Brake pedal	4-13	Coolant.....	7-13	Lubricating the swingarm pivots.....	7-29
Fuel tank cap	4-13	Cleaning the air filter element	7-15	Checking the front fork.....	7-29
Fuel.....	4-14	Adjusting the engine idling speed.....	7-16	Checking the steering.....	7-30
Catalytic converter	4-15	Adjusting the throttle grip free play	7-17	Checking the wheel bearings	7-30
Seats	4-16	Valve clearance	7-17	Battery	7-31
Helmet holder	4-17			Replacing the fuses	7-32
Sidestand	4-18				
Ignition circuit cut-off system	4-18				

Table of contents

Vehicle lights	7-33
Replacing a turn signal light bulb	7-33
Supporting the motorcycle.....	7-34
Front wheel.....	7-34
Rear wheel.....	7-36
Troubleshooting	7-38
Troubleshooting charts	7-39
Motorcycle care and storage	8-1
Matte color caution	8-1
Care.....	8-1
Storage.....	8-4
Specifications.....	9-1
Consumer information	10-1
Identification numbers.....	10-1
Motorcycle noise regulation (for Australia)	10-2
Index	11-1

Location of important labels

EAU10385

1

Read and understand all of the labels on your vehicle. They contain important information for safe and proper operation of your vehicle. Never remove any labels from your vehicle. If a label becomes difficult to read or comes off, a replacement label is available from your Yamaha dealer.

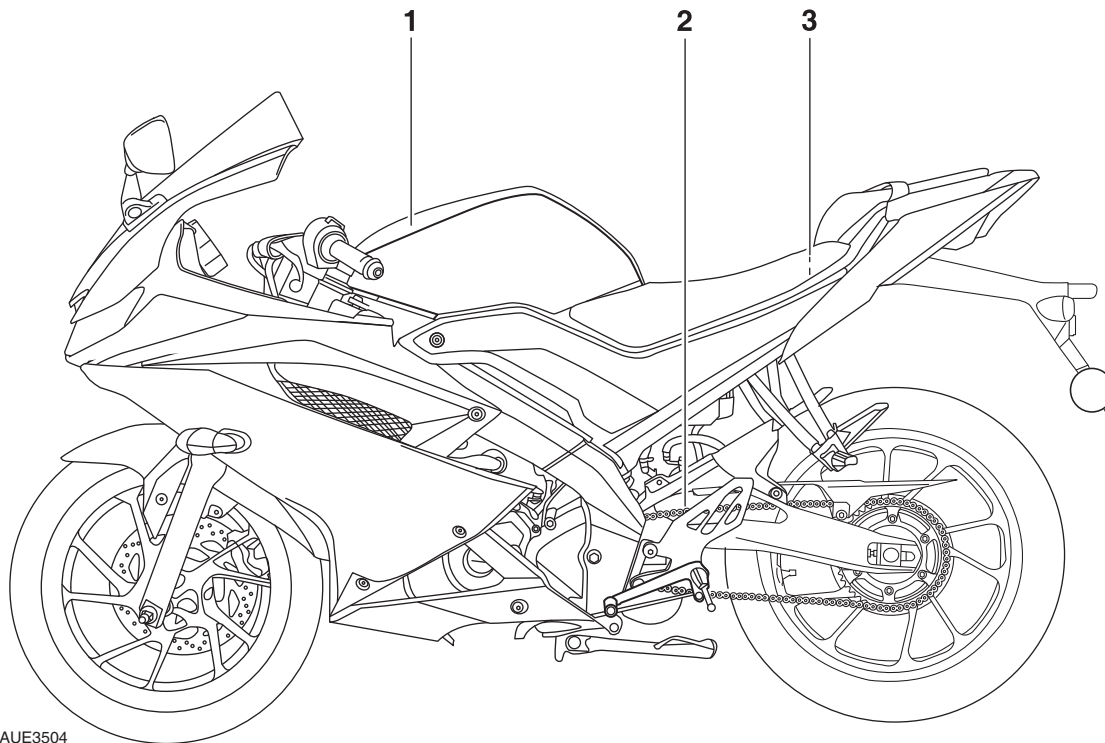

ZAUE3504

Location of important labels

1

1

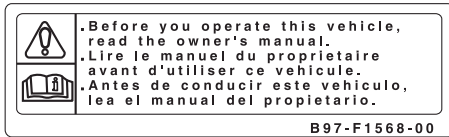

2

	kPa, psi	
100kPa=1bar		
	200, 29	225, 33
	200, 29	225, 33

BK7-F1668-00

3

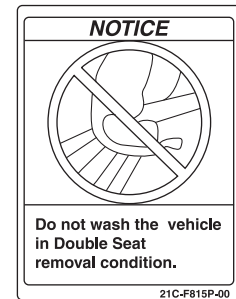

ZAUE3337

EAU1028C

2

Be a Responsible Owner

As the vehicle's owner, you are responsible for the safe and proper operation of your motorcycle.

Motorcycles are single-track vehicles. Their safe use and operation are dependent upon the use of proper riding techniques as well as the expertise of the operator. Every operator should know the following requirements before riding this motorcycle.

He or she should:

- Obtain thorough instructions from a competent source on all aspects of motorcycle operation.
- Observe the warnings and maintenance requirements in this Owner's Manual.
- Obtain qualified training in safe and proper riding techniques.
- Obtain professional technical service as indicated in this Owner's Manual and/or when made necessary by mechanical conditions.

- Never operate a motorcycle without proper training or instruction. Take a training course. Beginners should receive training from a certified instructor. Contact an authorized motorcycle dealer to find out about the training courses nearest you.

Safe Riding

Perform the pre-operation checks each time you use the vehicle to make sure it is in safe operating condition. Failure to inspect or maintain the vehicle properly increases the possibility of an accident or equipment damage. See page 5-1 for a list of pre-operation checks.

- This motorcycle is designed to carry the operator and a passenger.
- The failure of motorists to detect and recognize motorcycles in traffic is the predominating cause of automobile/motorcycle accidents. Many accidents have been caused by an automobile driver who did not see the motorcycle. Making yourself conspicuous ap-

pears to be very effective in reducing the chance of this type of accident.

Therefore:

- Wear a brightly colored jacket.
- Use extra caution when you are approaching and passing through intersections, since intersections are the most likely places for motorcycle accidents to occur.
- Ride where other motorists can see you. Avoid riding in another motorist's blind spot.
- Never maintain a motorcycle without proper knowledge. Contact an authorized motorcycle dealer to inform you on basic motorcycle maintenance. Certain maintenance can only be carried out by certified staff.

- Many accidents involve inexperienced operators. In fact, many operators who have been involved in accidents do not even have a current motorcycle license.
 - Make sure that you are qualified and that you only lend your motorcycle to other qualified operators.
 - Know your skills and limits. Staying within your limits may help you to avoid an accident.
 - We recommend that you practice riding your motorcycle where there is no traffic until you have become thoroughly familiar with the motorcycle and all of its controls.
- Many accidents have been caused by error of the motorcycle operator. A typical error made by the operator is veering wide on a turn due to excessive speed or undercornering (insufficient lean angle for the speed).
 - Always obey the speed limit and never travel faster than warranted by road and traffic conditions.
- Always signal before turning or changing lanes. Make sure that other motorists can see you.
- The posture of the operator and passenger is important for proper control.
 - The operator should keep both hands on the handlebar and both feet on the operator footrests during operation to maintain control of the motorcycle.
 - The passenger should always hold onto the operator, the seat strap or grab bar, if equipped, with both hands and keep both feet on the passenger footrests. Never carry a passenger unless he or she can firmly place both feet on the passenger footrests.
- Never ride under the influence of alcohol or other drugs.
- This motorcycle is designed for on-road use only. It is not suitable for off-road use.

Protective Apparel

The majority of fatalities from motorcycle accidents are the result of head injuries. The use of a safety helmet is the single most critical factor in the prevention or reduction of head injuries.

- Always wear an approved helmet.
- Wear a face shield or goggles. Wind in your unprotected eyes could contribute to an impairment of vision that could delay seeing a hazard.
- The use of a jacket, heavy boots, trousers, gloves, etc., is effective in preventing or reducing abrasions or lacerations.
- Never wear loose-fitting clothes, otherwise they could catch on the control levers, footrests, or wheels and cause injury or an accident.
- Always wear protective clothing that covers your legs, ankles, and feet. The engine or exhaust system become very hot during or after operation and can cause burns.
- A passenger should also observe the above precautions.

Safety information

2

Avoid Carbon Monoxide Poisoning

All engine exhaust contains carbon monoxide, a deadly gas. Breathing carbon monoxide can cause headaches, dizziness, drowsiness, nausea, confusion, and eventually death.

Carbon Monoxide is a colorless, odorless, tasteless gas which may be present even if you do not see or smell any engine exhaust. Deadly levels of carbon monoxide can collect rapidly and you can quickly be overcome and unable to save yourself. Also, deadly levels of carbon monoxide can linger for hours or days in enclosed or poorly ventilated areas. If you experience any symptoms of carbon monoxide poisoning, leave the area immediately, get fresh air, and **SEEK MEDICAL TREATMENT.**

- Do not run engine indoors. Even if you try to ventilate engine exhaust with fans or open windows and doors, carbon monoxide can rapidly reach dangerous levels.
- Do not run engine in poorly ventilated or partially enclosed areas such as barns, garages, or carports.

- Do not run engine outdoors where engine exhaust can be drawn into a building through openings such as windows and doors.

Loading

Adding accessories or cargo to your motorcycle can adversely affect stability and handling if the weight distribution of the motorcycle is changed. To avoid the possibility of an accident, use extreme caution when adding cargo or accessories to your motorcycle. Use extra care when riding a motorcycle that has added cargo or accessories. Here, along with the information about accessories below, are some general guidelines to follow if loading cargo to your motorcycle:

The total weight of the operator, passenger, accessories and cargo must not exceed the maximum load limit.

Operation of an overloaded vehicle could cause an accident.

Maximum load:
167 kg (368 lb)

When loading within this weight limit, keep the following in mind:

- Cargo and accessory weight should be kept as low and close to the motorcycle as possible. Securely pack your heaviest items as close to the center of the vehicle as possible and make sure to distribute the weight as evenly as possible on both sides of the motorcycle to minimize imbalance or instability.
- Shifting weights can create a sudden imbalance. Make sure that accessories and cargo are securely attached to the motorcycle before riding. Check accessory mounts and cargo restraints frequently.
- Properly adjust the suspension for your load (suspension-adjustable models only), and check the condition and pressure of your tires.
- Never attach any large or heavy items to the handlebar, front fork, or front fender. These items, including such cargo as sleeping bags, duffel bags, or

tents, can create unstable handling or a slow steering response.

- **This vehicle is not designed to pull a trailer or to be attached to a sidecar.**

Genuine Yamaha Accessories

Choosing accessories for your vehicle is an important decision. Genuine Yamaha accessories, which are available only from a Yamaha dealer, have been designed, tested, and approved by Yamaha for use on your vehicle.

Many companies with no connection to Yamaha manufacture parts and accessories or offer other modifications for Yamaha vehicles. Yamaha is not in a position to test the products that these aftermarket companies produce. Therefore, Yamaha can neither endorse nor recommend the use of accessories not sold by Yamaha or modifications not specifically recommended by Yamaha, even if sold and installed by a Yamaha dealer.

Aftermarket Parts, Accessories, and Modifications

While you may find aftermarket products similar in design and quality to genuine Yamaha accessories, recognize that some aftermarket accessories or modifications are not suitable because of potential safety hazards to you or others. Installing aftermarket products or having other modifications performed to your vehicle that change any of the vehicle's design or operation characteristics can put you and others at greater risk of serious injury or death. You are responsible for injuries related to changes in the vehicle.

Keep the following guidelines in mind, as well as those provided under "Loading" when mounting accessories.

- Never install accessories or carry cargo that would impair the performance of your motorcycle. Carefully inspect the accessory before using it to make sure that it does not in any way reduce ground clearance or cornering clearance, limit suspension travel,

steering travel or control operation, or obscure lights or reflectors.

- Accessories fitted to the handlebar or the front fork area can create instability due to improper weight distribution or aerodynamic changes. If accessories are added to the handlebar or front fork area, they must be as lightweight as possible and should be kept to a minimum.
- Bulky or large accessories may seriously affect the stability of the motorcycle due to aerodynamic effects. Wind may attempt to lift the motorcycle, or the motorcycle may become unstable in cross winds. These accessories may also cause instability when passing or being passed by large vehicles.
- Certain accessories can displace the operator from his or her normal riding position. This improper position limits the freedom of movement of the

Safety information

2

operator and may limit control ability, therefore, such accessories are not recommended.

- Use caution when adding electrical accessories. If electrical accessories exceed the capacity of the motorcycle's electrical system, an electric failure could result, which could cause a dangerous loss of lights or engine power.

Aftermarket Tires and Rims

The tires and rims that came with your motorcycle were designed to match the performance capabilities and to provide the best combination of handling, braking, and comfort. Other tires, rims, sizes, and combinations may not be appropriate. See page 7-18 for tire specifications and for information on servicing and replacing your tires.

Transporting the Motorcycle

Be sure to observe following instructions before transporting the motorcycle in another vehicle.

- Remove all loose items from the motorcycle.
- Check that the fuel cock (if equipped) is in the off position and that there are no fuel leaks.
- Shift the transmission into gear (for models with a manual transmission).
- Secure the motorcycle with tie-downs or suitable straps that are attached to solid parts of the motorcycle, such as the frame or upper front fork triple clamp (and not, for example, to rubber-mounted handlebars or turn signals, or parts that could break). Choose the location for the straps carefully so the straps will not rub against painted surfaces during transport.
- The suspension should be compressed somewhat by the tie-downs, if possible, so that the motorcycle will not bounce excessively during transport.

Further safe-riding points

EAU60590

- Be sure to signal clearly when making turns.
- Braking can be extremely difficult on a wet road. Avoid hard braking, because the vehicle could slide. Apply the brakes slowly when stopping on a wet surface.
- Slow down as you approach a corner or turn. Once you have completed a turn, accelerate slowly.
- Be careful when passing parked cars. A driver might not see you and open a door in your path.
- Railroad crossings, streetcar rails, iron plates on road construction sites, and manhole covers become extremely slippery when wet. Slow down and cross them with caution. Keep the vehicle upright, otherwise it could slide out from under you.
- The brake pads or linings could get wet when you wash the vehicle. After washing the vehicle, check the brakes before riding.

- Always wear a helmet, gloves, trousers (tapered around the cuff and ankle so they do not flap), and a brightly colored jacket.
- Do not carry too much luggage on the vehicle. An overloaded vehicle is unstable. Use a strong cord to secure any luggage to the carrier (if equipped). A loose load will affect the stability of the vehicle and could divert your attention from the road. (See page 2-3.)

Description

EAU10411

Left view

3

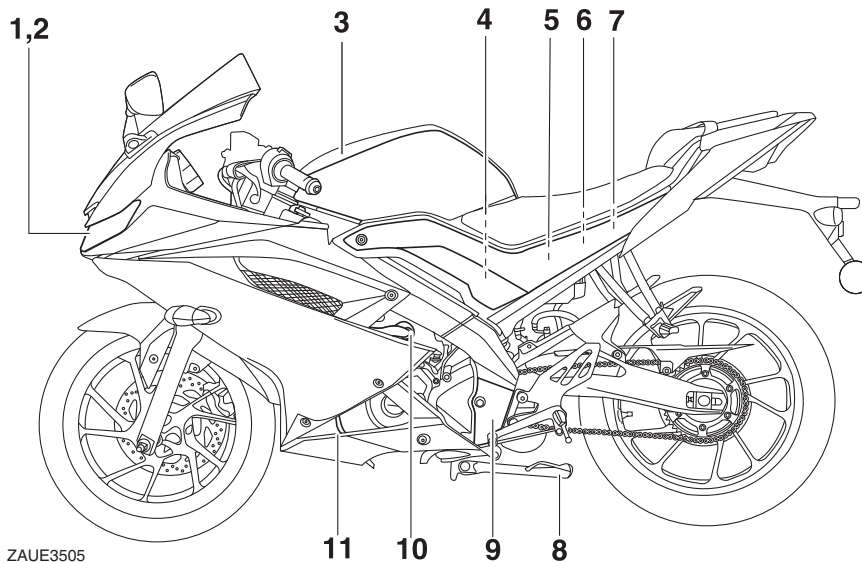

ZAUE3505

1. Headlight (page 7-33)
2. Auxiliary light
3. Fuel tank cap (page 4-13)
4. Air filter (page 7-15)
5. Battery (page 7-31)
6. Fuse (page 7-32)
7. Owner's tool kit (page 7-1)
8. Sidestand (page 4-18)

9. Shift pedal (page 4-12)
10. Idle adjusting screw (page 7-16)
11. Coolant reservoir (page 7-13)

Right view

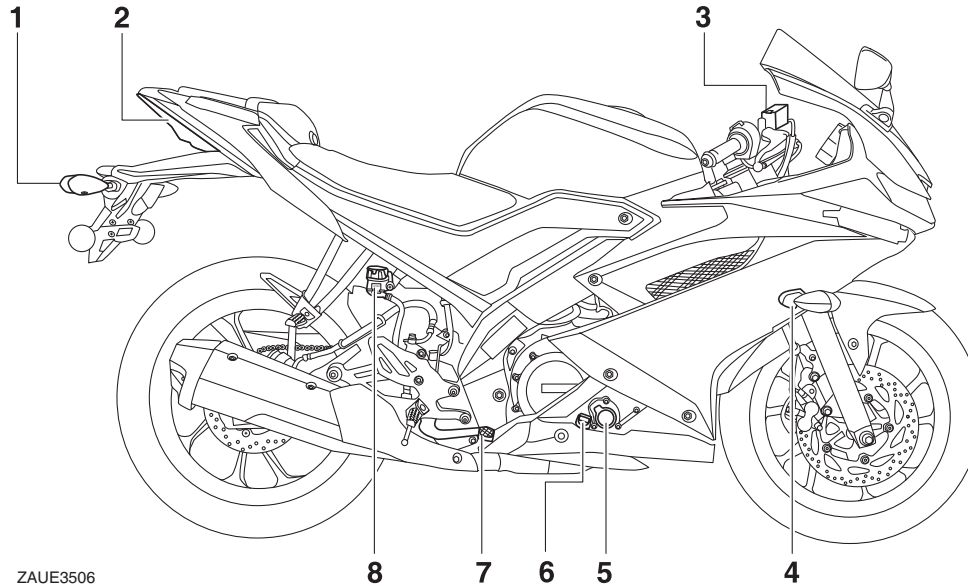

ZAUE3506

1. Rear turn signal light (page 7-33)
2. Tail/brake light
3. Front brake fluid reservoir (page 7-23)
4. Front turn signal light (page 7-33)
5. Engine oil filter element (page 7-10)
6. Dipstick (page 7-10)
7. Brake pedal (page 4-13)
8. Rear brake fluid reservoir (page 7-23)

Controls and instruments

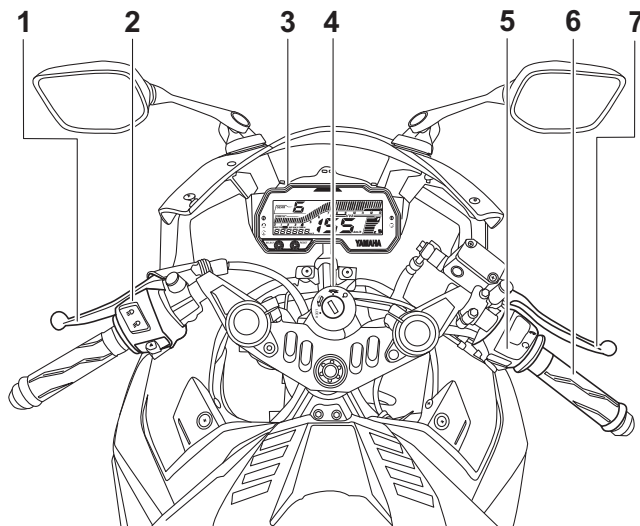
3

ZAUE3507

1. Clutch lever (page 4-12)
2. Left handlebar switches (page 4-11)
3. Multi-function meter unit (page 4-3)
4. Main switch/steering lock (page 4-1)
5. Right handlebar switches (page 4-11)
6. Throttle grip (page 7-17)
7. Brake lever (page 4-12)

Main switch/steering lock

EAU10462

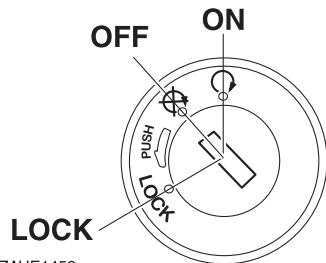

ZAUE1453

The main switch/steering lock controls the ignition and lighting systems, and is used to lock the steering. The various positions are described below.

○ (on)

EAUE3340

All electrical circuits are supplied with power. The meter lighting, taillight, license plate light and auxiliary lights come on, and the engine can be started. The key cannot be removed.

TIP

The headlight comes on automatically when the engine is started and stays on even if engine stop switch turn to "⊗". The headlight will turn off when the key is turned to "⊗".

EAU54301

⊗ (off)

All electrical systems are off. The key can be removed.

EWA16371

⚠ WARNING

Never turn the key to "⊗" or "LOCK" while the vehicle is moving. Otherwise the electrical systems will be switched off, which may result in loss of control or an accident.

EAU10696

LOCK

The steering is locked and all electrical systems are off. The key can be removed.

To lock the steering

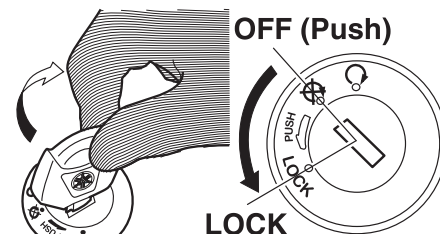

ZAUE2730

1. Turn the handlebars all the way to the left or right.
2. With the key in the "OFF" position, push the key in and turn it to "LOCK".
3. Remove the key.

TIP

If the steering will not lock, try turning the handlebars back to the right or left slightly.

Instrument and control functions

To unlock the steering

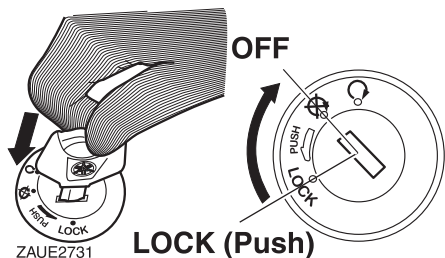



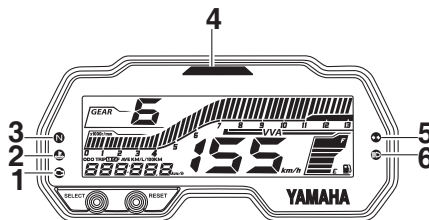

From the “LOCK” position, push the key and turn it to “OFF”.

Indicator lights and warning lights

EAU4939G



ZAUE3341

1. Engine trouble warning light “”
2. Coolant temperature warning light “”
3. Neutral indicator light “**N**”
4. Shift timing indicator light
5. Turn signal indicator light “ ”
6. High beam indicator light “”

Turn signal indicator light “ ”

EAU11022

This indicator light flashes when a turn signal light is flashing.

Neutral indicator light “**N**”

EAU11061

This indicator light comes on when the transmission is in the neutral position.

High beam indicator light “”

EAU11081

This indicator light comes on when the high beam of the headlight is switched on.

Coolant temperature warning light “”

EAUM3300

This warning light comes on if the engine overheats. If this occurs, stop the engine immediately and allow the engine to cool.

The electrical circuit of the warning light can be checked by turning the key to “**O**”. The warning light should come on for a few seconds, and then go off. If the warning light does not come on initially when the key is turned to “**O**”, or if the warning light remains on, have a Yamaha dealer check the electrical circuit.

NOTICE

ECA10022

Do not continue to operate the engine if it is overheating.

TIP

If the engine overheats, see page 7-40 for further instructions.

Engine trouble warning light “”

EAU68540

This warning light comes on or flashes if a problem is detected in the electrical circuit monitoring the engine. If this occurs, have a Yamaha dealer check the self-diagnosis system.

The electrical circuit of the warning light can be checked by turning the key to “○”. The warning light should come on for a few seconds, and then go off. If the warning light does not come on initially when the key is turned to “○”, or if the warning light remains on, have a Yamaha dealer check the electrical circuit.

Shift timing indicator light

EAU62470

This indicator light can be set to come on and go off at the desired engine speeds and is used to inform the rider when it is time to shift to the next high-

er gear. (See page 4-8 for a more detailed explanation of this indicator light and on how to set it.)

The electrical circuit of the indicator light can be checked by turning the key to “○”. The indicator light should come on for a few seconds, and then go off.

If the indicator light does not come on initially when the key is turned to “○”, or if the indicator light remains on, have a Yamaha dealer check the electrical circuit.

Multi-function meter unit

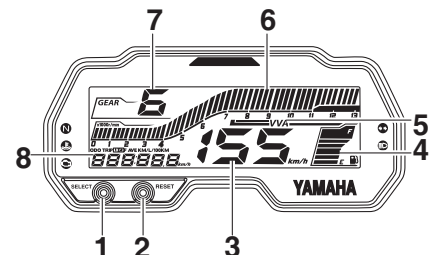

ZAUE3342

1. “SELECT” button
2. “RESET” button
3. Speedometer
4. Fuel meter
5. VVA (variable valve actuation) indicator
6. Tachometer
7. Transmission gear display
8. Multi-function display

The multi-function meter unit can be adjusted for the brightness screen.

To adjust the brightness screen

1. Turn the key to “”.
2. Push and hold the “SELECT” button.
3. Turn the key to “○” and then release the “SELECT” button after five seconds.

Instrument and control functions

4. Push the “RESET” button to select the desired brightness level.

EWA12423

⚠ WARNING

Be sure to stop the vehicle before making any setting changes to the multi-function meter unit. Changing settings while riding can distract the operator and increase the risk of an accident.

4

The multi-function meter unit is equipped with the following:

- a speedometer
- a fuel meter
- a VVA indicator
- a tachometer
- a transmission gear display
- a multi-function display
- a shift timing indicator light
- a self diagnosis device

Speedometer

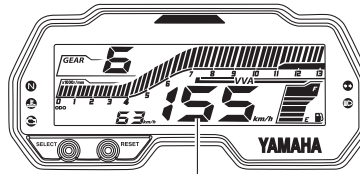

ZAUE3343

1. Speedometer

The speedometer shows the vehicle’s traveling speed.

Fuel meter

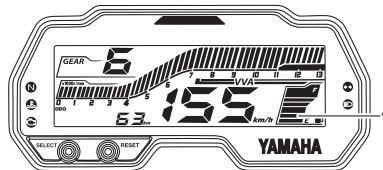

ZAUE3344

1. Fuel meter

The fuel meter indicates the amount of fuel in the fuel tank. The display segments of the fuel meter disappear towards “E” (empty) as the fuel level decreases. When the last segment start flashing, refuel as soon as possible.

When the key is turned to “Ⓞ”, the display segments of the fuel meter will sweep once across the fuel level range and then return to the current amount in order to test the electrical circuit.

VVA indicator

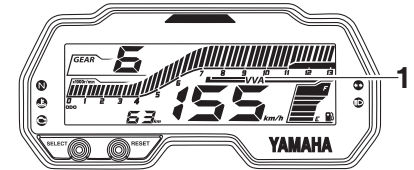

ZAUE3345

1. VVA (variable valve actuation) indicator

This model is equipped with variable valve actuation (VVA) for good fuel economy and acceleration in both the low-speed and high-speed ranges.

Instrument and control functions

The VVA indicator comes on when the variable valve actuation system has switched to the high-speed range.

Tachometer

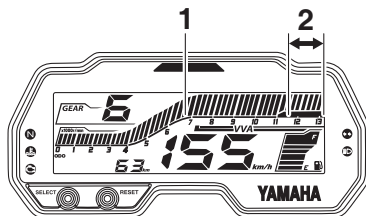

ZAUE3346

1. Tachometer
2. Tachometer red zone

The tachometer allows the rider to monitor the engine speed and keep it within the ideal power range.

ECA23050

NOTICE

Do not operate the engine in the tachometer high-r/min zone.

High-r/min zone: 11500 r/min and above

Transmission gear display

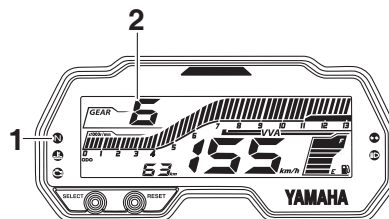

ZAUE3347

1. Neutral indicator light “N”
2. Transmission gear display

This display shows the selected gear. The neutral position is indicated by “-” and by the neutral indicator light.

Multi-function display

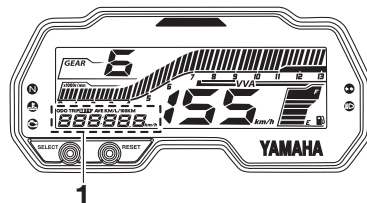

ZAUE3348

1. Multi-function display

The multi-function display is equipped with the following:

- an odometer
- two tripmeters
- a fuel reserve tripmeter
- a clock
- an instantaneous fuel consumption display
- an average fuel consumption display
- an average speed display
- welcome screen display

Push the “SELECT” button to switch the display between the odometer mode “ODO”, tripmeters mode “TRIP 1” and “TRIP 2”, clock mode “__:__:__”, instantaneous fuel consumption mode “km/L” or “L/100 km”, average fuel consumption mode “AVE__ km/L” or “AVE__ L/100 km” and average speed mode “AVE__ km/h” in the following order:

ODO → TRIP 1 → TRIP 2 → CLOCK → km/L or L/100 km → AVE__ km/L or AVE__ L/100 km → AVE__ km/h → ODO

Instrument and control functions

Push the “RESET” button to switch display backward.

If the last segment of the fuel meter starts flashing, the display automatically changes to the fuel reserve tripmeter mode “TRIP F” and starts counting the distance traveled from that point. In that case, push the “SELECT” button to switch the display between the various tripmeter, odometer, clock, instantaneous fuel consumption, average fuel consumption, and average speed modes in the following order:

TRIP F → CLOCK → km/L or L/100 km
→ AVE_ _ _ km/L or AVE_ _ _ L/100 km
→ AVE_ _ _ km/h → ODO → TRIP 1 →
TRIP 2 → TRIP F

To reset a tripmeter, select it by pushing the “SELECT” button and then push the “RESET” button for at least one second.

If you do not reset the fuel reserve tripmeter manually, it resets itself automatically and the display returns to the prior mode after refueling and traveling 5 km.

Odometer mode

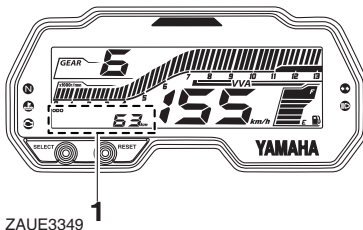

1. Odometer

The odometer shows the total distance traveled by the vehicle. It cannot be reset.

Tripmeters mode

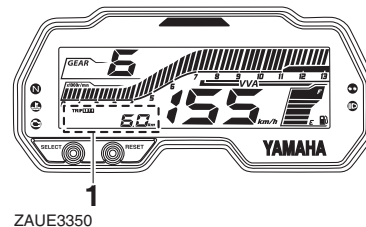

1. Tripmeter

The tripmeters shows the total distance traveled since they were last reset.

To reset a tripmeter, push the “RESET” button for one second.

TIP

- The odometer will lock at 999999 and cannot be reset.
- The tripmeters will reset and continue counting after 9999.9 is reached. To reset the tripmeters, while it is being displayed, press the “RESET” button for at least one second.

Instrument and control functions

Clock mode

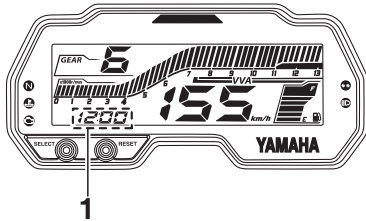

ZAUE3351

1. Clock

The clock uses a 12-hour time system.

To set the clock

1. Switch the display to the clock mode.
2. With the display in the clock mode, push and hold the “SELECT” and “RESET” button together.
3. When the hour digits start flashing, use the “RESET” button to set the hours.
4. Push the “SELECT” button and the minutes will start flashing.
5. Use the “RESET” button to set the minutes.

6. Push the “SELECT” button to start the clock.

Instantaneous fuel consumption mode

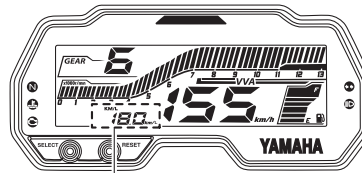

ZAUE3352 1

1. Instantaneous fuel consumption display

Shows the current fuel consumption when the vehicle is traveling at least 10 km/h.

There are two display modes: “km/L” and “L/100 km”

To switch the instantaneous fuel consumption display between “km/L” and “L/100 km”, push the “SELECT” button for one second.

- “km/L”: The distance that can be traveled on 1.0 L of fuel under the current riding conditions is shown.

- “L/100 km”: The amount of fuel necessary to travel 100 km under the current riding conditions is shown.

TIP

- If traveling at speeds under 10 km/h, “_ _ _” is displayed.
- The instantaneous fuel consumption function should be used for general reference only. Do not use this figure to estimate the distance that can be traveled on the current tank of fuel.

4

Average fuel consumption mode

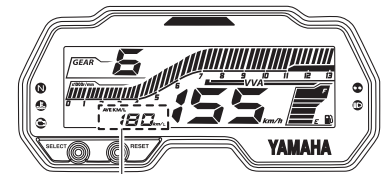

ZAUE3353 1

1. Average fuel consumption display

Show the average fuel consumption since it was last reset.

Instrument and control functions

There are two display mode: “AVE_ _ _ km/L” and “AVE_ _ _ L/100 km”.

To switch the average fuel consumption display between “AVE_ _ _ km/L” and “AVE_ _ _ L/100 km”, push the “SELECT” button for one second.

- “AVE_ _ _ km/L”: The average distance that can be traveled on 1.0 L of fuel is shown.
- “AVE_ _ _ L/100 km”: The average amount of fuel necessary to travel 100 km is shown.

To reset the average fuel consumption display, push and hold the “RESET” button.

TIP

- After resetting the average fuel consumption, “_ _ _” will be shown until the vehicle has traveled 1 km.
The average fuel consumption function should be used for general reference only. Do not use this figure to estimate the distance that can be traveled on the current tank of fuel.

Average speed mode

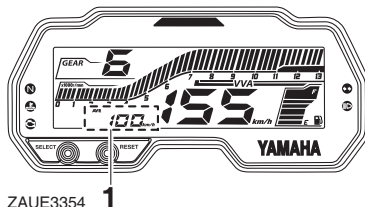

1. Average speed display

Shows the vehicle's traveling speed since it was last reset.

To reset the average speed display, push and hold the “RESET” button until the average speed flashes, and then push the button again .

Shift timing indicator light

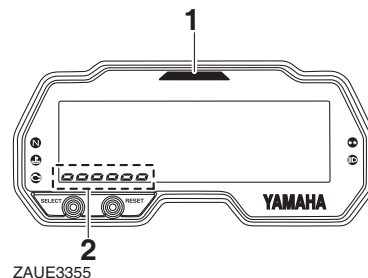

1. Shift timing indicator light
2. Brightness level display



The shift timing indicator light has four settings which can be adjusted.

- Flashing pattern: this function allows you to choose whether or not the indicator light will come on and whether it should flash or stay on when activated.
- Activation point: this function allows you to select the engine speed at which the indicator light is activated.
- Deactivation point: this function allows you to select the engine speed at which the indicator light is deactivated.

Instrument and control functions

- Brightness: this function allows you to adjust the brightness of the indicator light.

To adjust the shift timing indicator light

1. Turn the key to “”.
2. Push and hold the “SELECT” button.
3. Turn the key to “”, and then release the “SELECT” button after five seconds. After that push the “SELECT” button again. The shift timing indicator light can now be adjusted.

To set the flashing pattern

1. Push the “RESET” button to select one of the following flashing pattern settings:
 - On: the indicator light stays on when activated. (This setting is selected when the indicator light stays on.)
 - Flash: the indicator light flashes when activated. (This setting is selected when the indicator light flashes four times per second.)

- Off: the indicator light is deactivated; in other words, it does not come on or flash. (This setting is selected when the indicator light flashes once every two seconds.)
2. Push the “SELECT” button to confirm the selected flashing pattern. The shift timing indicator light changes to the activation point setting mode.

The tachometer will show the current setting r/min for the activation point and deactivation point setting modes.

To set the shift activation point

TIP

The shift timing indicator light activation point can be set between 9000 r/min and 13000 r/min. The indicator light can be set in increments of 250 r/min.

1. Push the “RESET” button to select the desired engine speed for activating the indicator light.

2. Push the “SELECT” button to confirm the selected engine speed. The control mode changes to the deactivation point setting mode.

To set the deactivation point

TIP

- The shift timing indicator light deactivation point can be set between 9000 r/min and 13000 r/min. The indicator light can be set in increments of 250 r/min.
- Be sure to set the deactivation point to a higher engine speed than for the activation point, otherwise the shift timing indicator light will not come on.

1. Push the “RESET” button to select the desired engine speed for deactivating the indicator light.
2. Push the “SELECT” button to confirm the selected engine speed. The control mode changes to the brightness setting mode.

Instrument and control functions

To adjust the brightness

1. Push the “RESET” button to select the desired shift indicator light brightness level.
2. Push the “SELECT” button to confirm the selected brightness level. The display exits the shift timing light control mode and returns to the standard multi-function display mode.

4

Welcome screen

The welcome screen greets the rider when the key is turned to “○” with the messages “Hi Buddy” and “see you” when the key is turned to “⊗”. The user name “Buddy” is set as the factory default, but it can be set to your name.

To set the user name

1. Turn the key to “⊗”.
2. Push and hold the “RESET” button.
3. Turn the key to “○”, and then release the “RESET” button after four seconds

4. When the first character starts flashing, push the “SELECT” button to change the character in the following order.

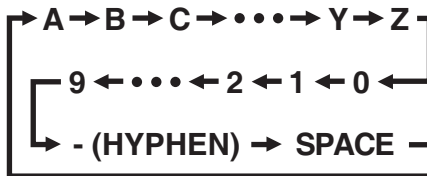

5. Push and hold the “SELECT” button to confirm the selected character. The second character will start flashing. Repeat this process for all six characters. After the sixth character is set, all characters will flash twice and the setting mode will automatically end.

Self-diagnosis device

This model is equipped with a self-diagnosis device for various electrical circuits.

If a problem is detected in any of those circuits, the engine trouble warning light will come on and the display will indicate an error code.

ECA11591

NOTICE

If the display indicates an error code, the vehicle should be checked as soon as possible in order to avoid engine damage.

Handlebar switches

EAU1234M

Left

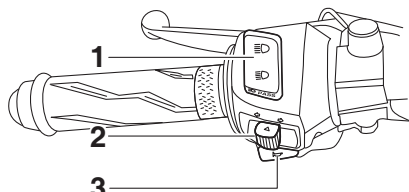

ZAUE3356

1. Dimmer/Pass switch “ \equiv ○/ \equiv ○/PASS”
2. Turn signal switch “ \leftarrow / \rightarrow ”
3. Horn switch “ 📢 ”

Right

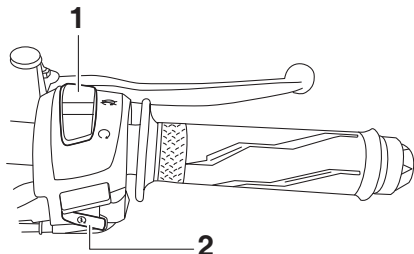

ZAUE3357

1. Engine stop switch “○/ 🛑 ”
2. Start switch “ 🌀 ”

Dimmer/Pass switch “ \equiv ○/ \equiv ○/PASS”

EAUE3630

Set this switch to “ \equiv ○” for the high beam and to “ \equiv ○” for the low beam. To flash the high beam, push the switch down towards “PASS” while the headlights are on low beam.

TIP

When the switch is set to low beam, the inner two headlights come on. When the switch is set to high beam, all four headlights come on.

Turn signal switch “ \leftarrow / \rightarrow ”

EAU12461

To signal a right-hand turn, push this switch to “ \rightarrow ”. To signal a left-hand turn, push this switch to “ \leftarrow ”. When released, the switch returns to the center position. To cancel the turn signal lights, push the switch in after it has returned to the center position.

Horn switch “ 📢 ”

EAU12501

Press this switch to sound the horn.

Engine stop switch “○/ 🛑 ”

EAU12663

Set this switch to “○” (run) before starting the engine. Set this switch to “ 🛑 ” (stop) to stop the engine in case of an emergency, such as in the event of an overturn or if the throttle is stuck.

Start switch “ 🌀 ”

EAU12713

Push this switch to crank the engine with the starter. See page 6-1 for starting instructions prior to starting the engine.

Instrument and control functions

Clutch lever

EAU31642

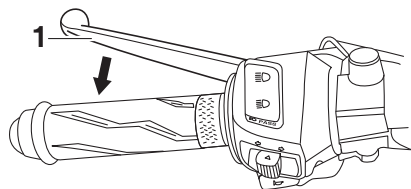

ZAUE3358

1. Clutch lever

The clutch lever is located on the left side of the handlebar. To disengage the clutch, pull the lever toward the handlebar grip. To engage the clutch, release the lever. The lever should be pulled rapidly and released slowly for smooth clutch operation.

The clutch lever is equipped with a clutch switch, which is part of the starting circuit cut-off system.

Shift pedal

EAU12875

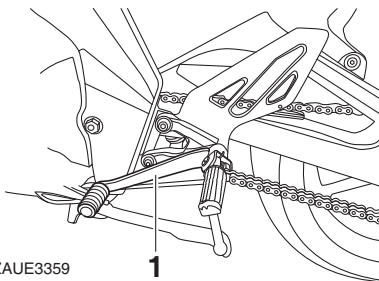

ZAUE3359

1. Shift pedal

The shift pedal is located on the left side of the motorcycle. To shift the transmission to a higher gear, move the shift pedal up. To shift to the transmission to a lower gear, move the shift pedal down. (See page 6-2.)

Brake lever

EAU12892

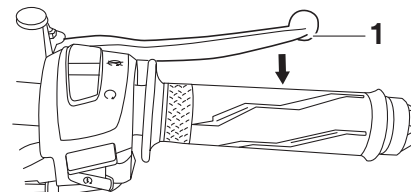

ZAUE3360

1. Brake lever

The brake lever is located on the right side of the handlebar. To apply the front brake, pull the lever toward the throttle grip.

Brake pedal

EAU12944

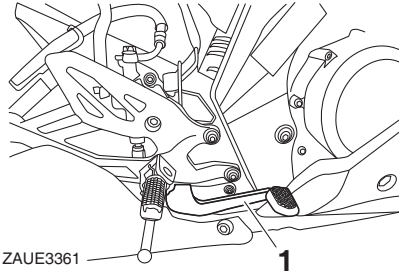

1. Brake pedal

The brake pedal is located on the right side of the motorcycle. To apply the rear brake, press down on the brake pedal.

Fuel tank cap

EAUE1481

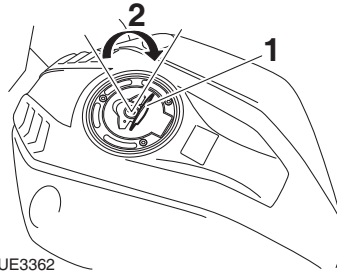

1. Fuel tank cap lock cover
2. Unlock.

To remove the fuel tank cap

1. Open the fuel tank cap lock cover.
2. Insert the key into the lock and turn it 1/4 turn clockwise. The lock will be released and the fuel tank cap can be removed.

To install the fuel tank cap

1. Push the fuel tank cap into position with the key inserted in the lock.
2. Turn the key counterclockwise to the original position, and then remove it.
3. Close the lock cover.

TIP

The fuel tank cap cannot be installed unless the key is in the lock. In addition, the key cannot be removed if the cap is not properly installed and locked.

EWA11142

WARNING

Make sure that the fuel tank cap is properly installed before riding. Leaking fuel is a fire hazard.

Instrument and control functions

Fuel

Make sure there is sufficient gasoline in the tank.

EAU13213

EWA10882

WARNING

Gasoline and gasoline vapors are extremely flammable. To avoid fires and explosions and to reduce the risk of injury when refueling, follow these instructions.

1. Before refueling, turn off the engine and be sure that no one is sitting on the vehicle. Never refuel while smoking, or while in the vicinity of sparks, open flames, or other sources of ignition such as the pilot lights of water heaters and clothes dryers.
2. Do not overfill the fuel tank. Stop filling when the fuel reaches the bottom of the filler tube. Because fuel expands when it heats up, heat from the engine or the sun can cause fuel to spill out of the fuel tank.

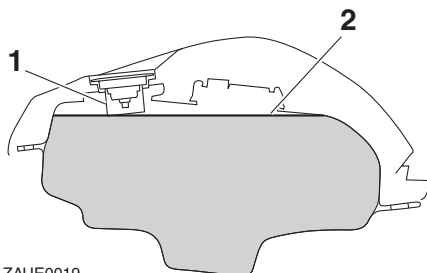

ZAUE0019

1. Fuel tank filler tube
2. Maximum fuel level
3. Wipe up any spilled fuel immediately. **NOTICE: Immediately wipe off spilled fuel with a clean, dry, soft cloth, since fuel may deteriorate painted surfaces or plastic parts.** [ECA10072]
4. Be sure to securely close the fuel tank cap.

EWA15152

WARNING

Gasoline is poisonous and can cause injury or death. Handle gasoline with care. Never siphon gasoline by mouth. If you should swallow some gasoline or inhale a lot of gasoline vapor, or get some gasoline in your eyes, see your doctor immedi-

ately. If gasoline spills on your skin, wash with soap and water. If gasoline spills on your clothing, change your clothes.

EAU53073

Recommended fuel:

Regular unleaded gasoline only

Fuel tank capacity:

11 L (2.9 US gal, 2.4 Imp.gal)

Fuel reserve amount:

1.9 L (0.50 US gal, 0.42 Imp.gal)

ECA11401

NOTICE

Use only unleaded gasoline. The use of leaded gasoline will cause severe damage to internal engine parts, such as the valves and piston rings, as well as to the exhaust system.

Your Yamaha engine has been designed to use regular unleaded gasoline with a research octane number of 91 or higher. If knocking (or pinging) occurs, use a gasoline of a different brand or premium unleaded fuel. Use of unleaded fuel will extend spark plug life and reduce maintenance costs.

Gasohol

There are two types of gasohol: gasohol containing ethanol and that containing methanol. Gasohol containing ethanol can be used if the ethanol content does not exceed 10% (E10). Gasohol containing methanol is not recommended by Yamaha because it can cause damage to the fuel system or vehicle performance problems.

Catalytic converter

EAU13434

This model is equipped with a catalytic converter in the exhaust system.

EWA10863

WARNING

The exhaust system is hot after operation. To prevent a fire hazard or burns:

- Do not park the vehicle near possible fire hazards such as grass or other materials that easily burn.
- Park the vehicle in a place where pedestrians or children are not likely to touch the hot exhaust system.
- Make sure that the exhaust system has cooled down before doing any maintenance work.
- Do not allow the engine to idle more than a few minutes. Long idling can cause a build-up of heat.

ECA10702

NOTICE

Use only unleaded gasoline. The use of leaded gasoline will cause unreparable damage to the catalytic converter.

Instrument and control functions

Seats

EAUE3430

Passenger seat

To remove the passenger seat

1. Remove the plastic cover.

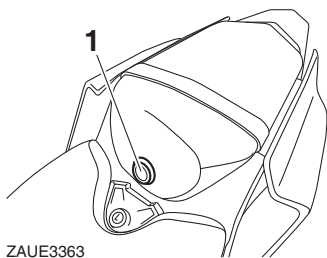

1. Plastic cover

2. Remove the nut and then slide in forward direction to remove the passenger seat as shown.

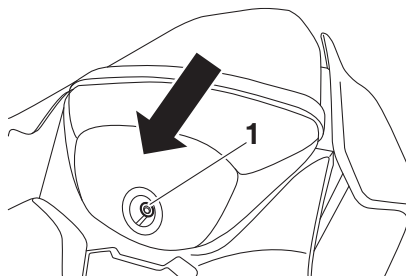

1. Nut

To install the passenger seat

1. Insert the projections on the front of the passenger seat into the seat holders as shown, and then place the seat in the original position.

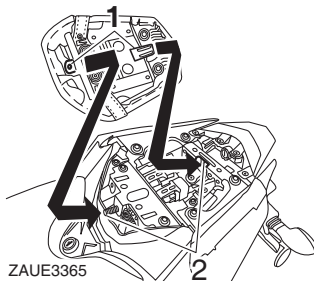

1. Projection
2. Seat holder

2. Install the passenger seat by installing the nut.
3. Install the plastic cover.

Rider seat

To remove the rider seat

1. Insert the key into the seat lock, and then turn it clockwise.

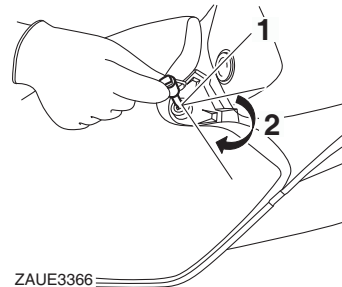

1. Rider seat lock
2. Unlock.

2. While holding the key in the position "2", lift from rear of the rider seat and pull it backward.

To install the rider seat

1. Insert the projection on the front of the rider seat into the seat holder as shown, place the seat in the original position.

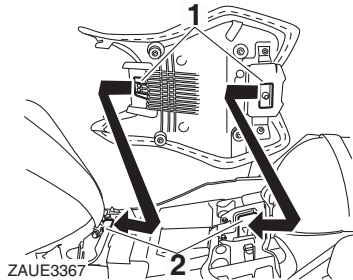

1. Projection
2. Seat holder

2. Remove the key.

TIP

Make sure that the seats are properly secured before riding.

Helmet holder

EAU14326

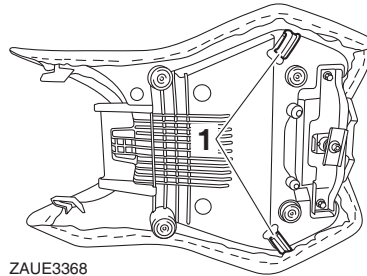

1. Helmet holder

The helmet holder is located under the rider seat.

To secure a helmet to the helmet holder

1. Remove the rider seat. (See page 4-16.)
2. Hook the helmet onto the helmet holder, and then securely install the seat. **WARNING! Never ride with a helmet attached to the helmet holder, since the helmet may hit objects, causing loss of control and possibly an accident.** [EWA10162]

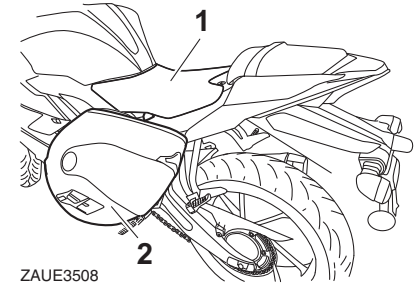

1. Rider seat
2. Helmet

To release the helmet from the helmet holder

Remove the rider seat, remove the helmet from the helmet holder, and then install the seat.

Instrument and control functions

Sidestand

EAU15306

The sidestand is located on the left side of the frame. Raise the sidestand or lower it with your foot while holding the vehicle upright.

TIP

The built-in sidestand switch is part of the ignition circuit cut-off system, which cuts the ignition in certain situations. (See the following section for an explanation of the ignition circuit cut-off system.)

4

EWA10242

WARNING

The vehicle must not be ridden with the sidestand down, or if the sidestand cannot be properly moved up (or does not stay up), otherwise the sidestand could contact the ground and distract the operator, resulting in a possible loss of control. Yamaha's ignition circuit cut-off system has been designed to assist the operator in fulfilling the responsibility of raising the sidestand before starting off. Therefore, check

this system regularly and have a Yamaha dealer repair it if it does not function properly.

EAU44895

Ignition circuit cut-off system

This system prevents in-gear engine starts unless the clutch lever is pulled and the sidestand is up. Also, it will stop the running engine should the sidestand be lowered while the transmission is in gear.

Periodically check the system via the following procedure.

TIP

- This check is most reliable if performed with a warmed-up engine.
 - See pages 4-1 and 4-11 for switch operation information.
-

Instrument and control functions

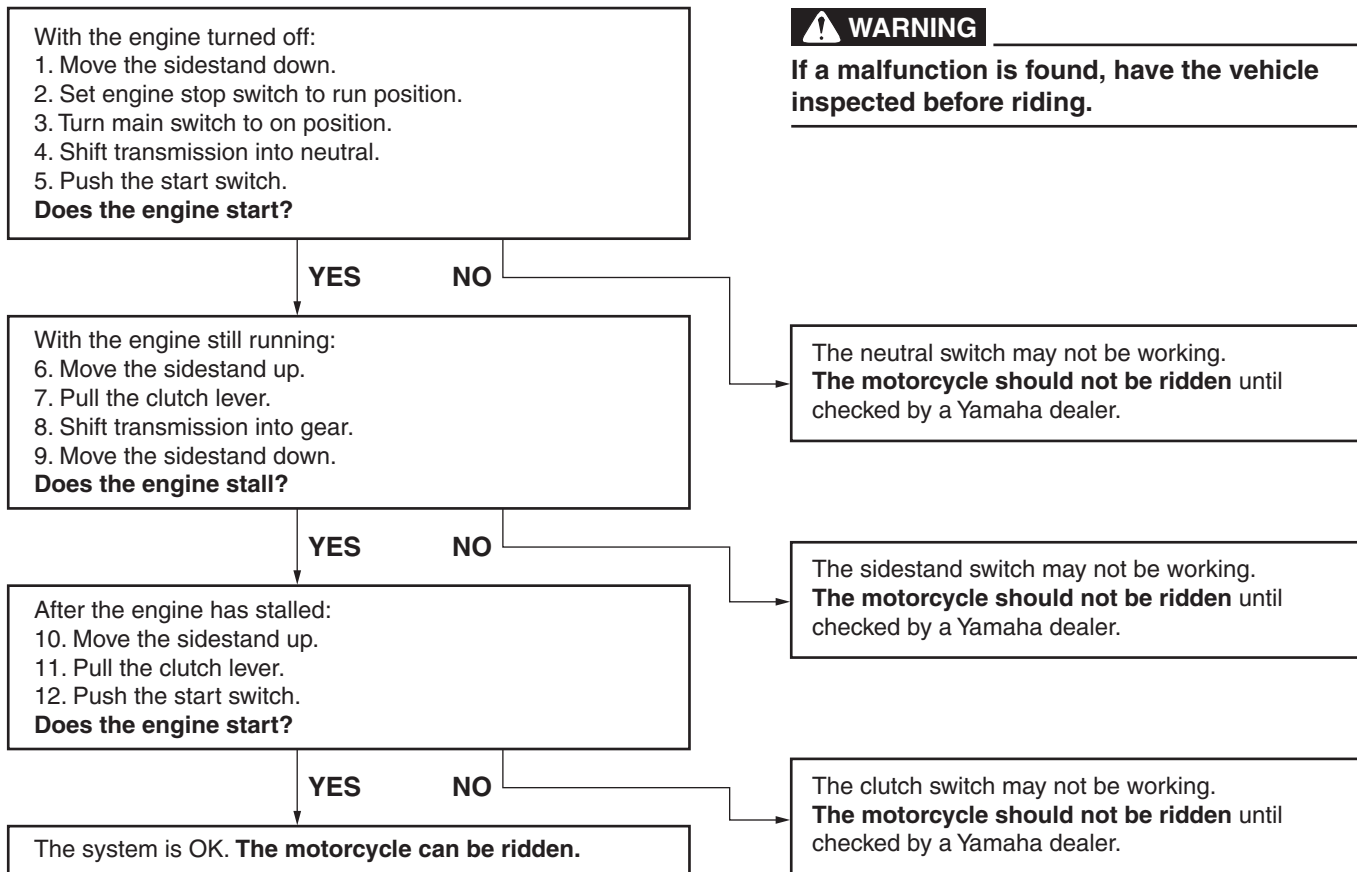

For your safety – pre-operation checks

EAU15599

Inspect your vehicle each time you use it to make sure the vehicle is in safe operating condition. Always follow the inspection and maintenance procedures and schedules described in the Owner's Manual.

EWA11152

WARNING

Failure to inspect or maintain the vehicle properly increases the possibility of an accident or equipment damage. Do not operate the vehicle if you find any problem. If a problem cannot be corrected by the procedures provided in this manual, have the vehicle inspected by a Yamaha dealer.

Before using this vehicle, check the following points:

ITEM	CHECKS	PAGE
Fuel	<ul style="list-style-type: none">• Check fuel level in fuel tank.• Refuel if necessary.• Check fuel line for leakage.	4-14
Engine oil	<ul style="list-style-type: none">• Check oil level in engine.• If necessary, add recommended oil to specified level.• Check vehicle for oil leakage.	7-10
Coolant	<ul style="list-style-type: none">• Check coolant level in reservoir.• If necessary, add recommended coolant to specified level.• Check cooling system for leakage.	7-13
Front brake	<ul style="list-style-type: none">• Check operation.• If soft or spongy, have Yamaha dealer bleed hydraulic system.• Check brake pads for wear.• Replace if necessary.• Check fluid level in reservoir.• If necessary, add specified brake fluid to specified level.• Check hydraulic system for leakage.	7-22, 7-23

5

For your safety – pre-operation checks

ITEM	CHECKS	PAGE
Rear brake	<ul style="list-style-type: none"> • Check operation. • If soft or spongy, have Yamaha dealer bleed hydraulic system. • Check brake pads for wear. • Replace if necessary. • Check fluid level in reservoir. • If necessary, add specified brake fluid to specified level. • Check hydraulic system for leakage. 	7-22, 7-23
Clutch	<ul style="list-style-type: none"> • Check operation. • Lubricate cable if necessary. • Check lever free play. • Adjust if necessary. 	7-20
Throttle grip	<ul style="list-style-type: none"> • Make sure that operation is smooth. • Check throttle grip free play. • If necessary, have Yamaha dealer adjust throttle grip free play and lubricate cable end and grip housing. 	7-17, 7-27
Control cables	<ul style="list-style-type: none"> • Make sure that operation is smooth. • Lubricate cable ends if necessary. 	7-27
Drive chain	<ul style="list-style-type: none"> • Check chain slack. • Adjust if necessary. • Check chain condition. • Lubricate if necessary. 	7-24, 7-26
Wheels and tires	<ul style="list-style-type: none"> • Check for damage. • Check tire condition and tread depth. • Check air pressure. • Correct if necessary. 	7-18, 7-19
Brake and shift pedals	<ul style="list-style-type: none"> • Make sure that operation is smooth. • Lubricate pedal pivoting points if necessary. 	7-27
Brake and clutch levers	<ul style="list-style-type: none"> • Make sure that operation is smooth. • Lubricate lever pivoting points if necessary. 	7-28
Sidestand	<ul style="list-style-type: none"> • Make sure that operation is smooth. • Lubricate pivot if necessary. 	7-29

For your safety – pre-operation checks

ITEM	CHECKS	PAGE
Chassis fasteners	<ul style="list-style-type: none">• Make sure that all nuts, bolts and screws are properly tightened.• Tighten if necessary.	–
Instruments, lights, signals and switches	<ul style="list-style-type: none">• Check operation.• Correct if necessary.	–
Sidestand switch	<ul style="list-style-type: none">• Check operation of ignition circuit cut-off system.• If system is not working correctly, have Yamaha dealer check vehicle.	4-18

EAU15952

Read the Owner's Manual carefully to become familiar with all controls. If there is a control or function you do not understand, ask your Yamaha dealer.

EWA10272



WARNING

Failure to familiarize yourself with the controls can lead to loss of control, which could cause an accident or injury.

EAUM2327

Starting the engine

In order for the ignition circuit cut-off system to enable starting, one of the following conditions must be met:

- The transmission is in the neutral position.
- The transmission is in gear with the clutch lever pulled and the sidestand up.

See page 4-18 for more information.

1. Turn the key to "ON" and make sure that the engine stop switch is set to "○".

The following warning lights and indicator light should come on for a few seconds, then go off.

- Neutral indicator light
- Turn signal indicator light
- High beam indicator light
- Coolant temperature warning light
- Engine trouble warning light

ECA11834

NOTICE

If a warning or indicator light does not come on initially when the key is turned to "ON", or if a warning or in-

dicator light remains on, see page 4-2 for the corresponding warning and indicator light circuit check.

2. Shift the transmission into the neutral position. The neutral indicator light should come on. If not, ask a Yamaha dealer to check the electrical circuit.
3. Start the engine by pushing the start switch.

If the engine fails to start, release the start switch, wait a few seconds, and then try again. Each starting attempt should be as short as possible to preserve the battery. Do not crank the engine more than 10 seconds on any one attempt.

ECA11043

NOTICE

For maximum engine life, never accelerate hard when the engine is cold!

Operation and important riding points

Shifting

EAU16674

ECA10261

EAU16811

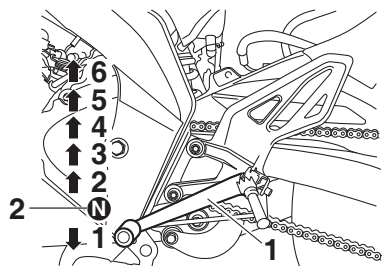

ZAUE3370

1. Shift pedal
2. Neutral position

Shifting gears lets you control the amount of engine power available for starting off, accelerating, climbing hills, etc.

The gear positions are shown in the illustration.

TIP

To shift the transmission into the neutral position (N), press the shift pedal down repeatedly until it reaches the end of its travel, and then slightly raise it.

NOTICE

- Even with the transmission in the neutral position, do not coast for long periods of time with the engine off, and do not tow the motorcycle for long distances. The transmission is properly lubricated only when the engine is running. Inadequate lubrication may damage the transmission.
- Always use the clutch while changing gears to avoid damaging the engine, transmission, and drive train, which are not designed to withstand the shock of forced shifting.

Tips for reducing fuel consumption

Fuel consumption depends largely on your riding style. Consider the following tips to reduce fuel consumption:

- Shift up swiftly, and avoid high engine speeds during acceleration.
- Do not rev the engine while shifting down, and avoid high engine speeds with no load on the engine.
- Turn the engine off instead of letting it idle for an extended length of time (e.g., in traffic jams, at traffic lights or at railroad crossings).

Engine break-in

EAU16831

There is never a more important period in the life of your engine than the period between 0 and 1000 km (600 mi). For this reason, you should read the following material carefully.

Since the engine is brand new, do not put an excessive load on it for the first 1000 km (600 mi). The various parts in the engine wear and polish themselves to the correct operating clearances. During this period, prolonged full-throttle operation or any condition that might result in engine overheating must be avoided.

EAU16983

0–500 km (0–300 mi)

Avoid prolonged operation above 5000 r/min.

After every hour of operation, stop the engine, and then let it cool for five to ten minutes.

Vary the engine speed from time to time. Do not operate the engine at one set throttle position.

500–1000 km (300–600 mi)

Avoid prolonged operation above 7500 r/min.

Rev the engine freely through the gears, but do not use full throttle at any time. **NOTICE: After 1000 km (600 mi) of operation, the engine oil must be changed, the oil filter cartridge or element replaced, and the oil strainer cleaned.**^[ECA10322]

1000 km (600 mi) and beyond

The vehicle can now be operated normally.

ECA10311

NOTICE

- Keep the engine speed out of the tachometer red zone.
- If any engine trouble should occur during the engine break-in period, immediately have a Yamaha dealer check the vehicle.

EAU17214

Parking

When parking, stop the engine, and then remove the key from the main switch.

EWA10312

WARNING

- Since the engine and exhaust system can become very hot, park in a place where pedestrians or children are not likely to touch them and be burned.
- Do not park on a slope or on soft ground, otherwise the vehicle may overturn, increasing the risk of a fuel leak and fire.
- Do not park near grass or other flammable materials which might catch fire.

Periodic maintenance and adjustment

EAU17246

Periodic inspection, adjustment, and lubrication will keep your vehicle in the safest and most efficient condition possible. Safety is an obligation of the vehicle owner/operator. The most important points of vehicle inspection, adjustment, and lubrication are explained on the following pages.

The intervals given in the periodic maintenance charts should be simply considered as a general guide under normal riding conditions. However, depending on the weather, terrain, geographical location, and individual use, the maintenance intervals may need to be shortened.

EWA10322

WARNING

Failure to properly maintain the vehicle or performing maintenance activities incorrectly may increase your risk of injury or death during service or while using the vehicle. If you are not familiar with vehicle service, have a Yamaha dealer perform service.

EWA15123

WARNING

Turn off the engine when performing maintenance unless otherwise specified.

- **A running engine has moving parts that can catch on body parts or clothing and electrical parts that can cause shocks or fires.**
- **Running the engine while servicing can lead to eye injury, burns, fire, or carbon monoxide poisoning – possibly leading to death. See page 2-3 for more information about carbon monoxide.**

EWA15461

WARNING

Brake discs, calipers, drums, and linings can become very hot during use. To avoid possible burns, let brake components cool before touching them.

EAU17362

Owner's tool kit

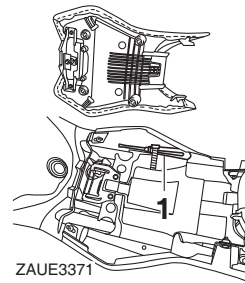

ZAUE3371

1. Owner's tool kit

The owner's tool kit is located under the rider seat. (See page 4-16.) The service information included in this manual and the tools provided in the owner's tool kit are intended to assist you in the performance of preventive maintenance and minor repairs. However, additional tools such as a torque wrench may be necessary to perform certain maintenance work correctly.

TIP

If you do not have the tools or experience required for a particular job, have a Yamaha dealer perform it for you.

Periodic maintenance and adjustment

EAU71021

TIP

- The annual checks must be performed every year, except if a distance-based maintenance is performed instead.
- From 30000 km (17500 mi), repeat the maintenance intervals starting from 6000 km (3500 mi).
- Items marked with an asterisk should be performed by a Yamaha dealer as they require special tools, data and technical skills.

EAU71040

Periodic maintenance chart for the emission control system

NO.	ITEM	CHECK OR MAINTENANCE JOB	ODOMETER READING					ANNUAL CHECK
			1000 km (600 mi)	6000 km (3500 mi)	12000 km (7000 mi)	18000 km (10500 mi)	24000 km (14000 mi)	
1	* Fuel line	<ul style="list-style-type: none"> • Check fuel hoses for cracks or damage. • Replace if necessary. 		√	√	√	√	√
2	* Spark plug	<ul style="list-style-type: none"> • Check condition. • Adjust gap and clean. 		√		√		
		<ul style="list-style-type: none"> • Replace. 			√		√	
3	* Valve clearance	<ul style="list-style-type: none"> • Check and adjust. 		√	√	√	√	
4	* Fuel injection	<ul style="list-style-type: none"> • Check and adjust engine idle speed. 	√	√	√	√	√	√
5	* Exhaust system	<ul style="list-style-type: none"> • Check for leakage. • Tighten if necessary. • Replace gasket if necessary. 	√	√	√	√	√	

Periodic maintenance and adjustment

EAU71342

General maintenance and lubrication chart

NO.	ITEM	CHECK OR MAINTENANCE JOB	ODOMETER READING					ANNUAL CHECK
			1000 km (600 mi)	6000 km (3500 mi)	12000 km (7000 mi)	18000 km (10500 mi)	24000 km (14000 mi)	
1	* Diagnostic system check	<ul style="list-style-type: none"> • Perform dynamic inspection using Yamaha diagnostic tool. • Check the error codes. 	√	√	√	√	√	√
2	* Air filter element	• Clean.		√		√		
		• Replace.			√		√	
3	Air filter case check hose	• Clean.	√	√	√	√	√	
4	Clutch	<ul style="list-style-type: none"> • Check operation. • Adjust. 	√	√	√	√	√	
5	* Front brake	<ul style="list-style-type: none"> • Check operation, fluid level, and for fluid leakage. • Replace brake pads if necessary. 	√	√	√	√	√	√
6	* Rear brake	<ul style="list-style-type: none"> • Check operation, fluid level, and for fluid leakage. • Replace brake pads if necessary. 	√	√	√	√	√	√
7	* Brake hoses	• Check for cracks or damage.		√	√	√	√	√
		• Replace.	Every 4 years					
8	* Brake fluid	• Change.	Every 2 years					
9	* Wheels	<ul style="list-style-type: none"> • Check runout and for damage. • Replace if necessary. 		√	√	√	√	
10	* Tires	<ul style="list-style-type: none"> • Check tread depth and for damage. • Replace if necessary. • Check air pressure. • Correct if necessary. 		√	√	√	√	√

7

Periodic maintenance and adjustment

NO.	ITEM	CHECK OR MAINTENANCE JOB	ODOMETER READING					ANNUAL CHECK
			1000 km (600 mi)	6000 km (3500 mi)	12000 km (7000 mi)	18000 km (10500 mi)	24000 km (14000 mi)	
11	* Wheel bearings	<ul style="list-style-type: none"> • Check bearing for looseness or damage. 		√	√	√	√	
12	* Swingarm pivot bearings	<ul style="list-style-type: none"> • Check operation and for excessive play. 		√	√	√	√	
		<ul style="list-style-type: none"> • Lubricate with lithium-soap-based grease. 	Every 24000 km (14000 mi)					
13	Drive chain	<ul style="list-style-type: none"> • Check chain slack, alignment and condition. • Adjust and lubricate chain with a special O-ring chain lubricant thoroughly. 	Every 1000 km (600 mi) and after washing the motorcycle, riding in the rain or riding in wet areas					
14	* Steering bearings	<ul style="list-style-type: none"> • Check bearing assemblies for looseness. 	√	√	√	√		
		<ul style="list-style-type: none"> • Moderately repack with lithium-soap-based grease. 					√	
15	* Chassis fasteners	<ul style="list-style-type: none"> • Make sure that all nuts, bolts and screws are properly tightened. 		√	√	√	√	√
16	Brake lever pivot shaft	<ul style="list-style-type: none"> • Lubricate with silicone grease. 		√	√	√	√	√
17	Brake pedal pivot shaft	<ul style="list-style-type: none"> • Lubricate with lithium-soap-based grease. 		√	√	√	√	√
18	Clutch lever pivot shaft	<ul style="list-style-type: none"> • Lubricate with lithium-soap-based grease. 		√	√	√	√	√
19	Shift pedal pivot shaft	<ul style="list-style-type: none"> • Lubricate with lithium-soap-based grease. 		√	√	√	√	√

Periodic maintenance and adjustment

NO.	ITEM	CHECK OR MAINTENANCE JOB	ODOMETER READING					ANNUAL CHECK
			1000 km (600 mi)	6000 km (3500 mi)	12000 km (7000 mi)	18000 km (10500 mi)	24000 km (14000 mi)	
20	Sidestand	<ul style="list-style-type: none"> • Check operation. • Lubricate with lithium-soap-based grease. 		√	√	√	√	√
21 *	Sidestand switch	<ul style="list-style-type: none"> • Check operation and replace if necessary. 	√	√	√	√	√	√
22 *	Front fork	<ul style="list-style-type: none"> • Check operation and for oil leakage. • Replace if necessary. 		√	√	√	√	
23 *	Shock absorber assembly	<ul style="list-style-type: none"> • Check operation and for oil leakage. • Replace if necessary. 		√	√	√	√	
24 *	Rear suspension relay arm and connecting arm pivoting points	<ul style="list-style-type: none"> • Check operation. 		√	√	√	√	
		<ul style="list-style-type: none"> • Lubricate with lithium-soap-based grease. 			√		√	
25	Engine oil	<ul style="list-style-type: none"> • Change (warm engine before draining). • Check oil level and vehicle for oil leakage. 	√	√	√	√	√	√
26	Engine oil filter element	<ul style="list-style-type: none"> • Replace. 	√		√		√	
27 *	Cooling system	<ul style="list-style-type: none"> • Check coolant level and vehicle for coolant leakage. 		√	√	√	√	√
		<ul style="list-style-type: none"> • Change. 	Every 3 years					
28 *	Front and rear brake switches	<ul style="list-style-type: none"> • Check operation. 	√	√	√	√	√	√
29 *	Moving parts and cables	<ul style="list-style-type: none"> • Lubricate. 		√	√	√	√	√

Periodic maintenance and adjustment

NO.	ITEM	CHECK OR MAINTENANCE JOB	ODOMETER READING					ANNUAL CHECK
			1000 km (600 mi)	6000 km (3500 mi)	12000 km (7000 mi)	18000 km (10500 mi)	24000 km (14000 mi)	
30	* Throttle grip housing and cable	<ul style="list-style-type: none"> • Check operation and free play. • Adjust the throttle cable free play if necessary. • Lubricate the throttle grip housing and cable. 		√	√	√	√	√
31	* Lights, signals and switches	<ul style="list-style-type: none"> • Check operation. • Adjust headlight beam. 	√	√	√	√	√	√

EAU72750

TIP

- The air filter needs more frequent service if you are riding in unusually wet or dusty areas.
- Hydraulic brake service
 - Regularly check and, if necessary, correct the brake fluid level.
 - Every two years replace the internal components of the brake master cylinders and calipers, and change the brake fluid.
 - Replace the brake hoses every four years and if cracked or damaged.

Periodic maintenance and adjustment

Removing and installing the cowling and panels

EAU18724

The cowling and panels shown need to be removed to perform some of the maintenance jobs described in this chapter. Refer to this section each time the cowling or a panel needs to be removed and installed.

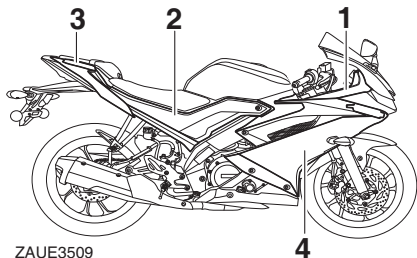

1. Panel A
2. Panel B
3. Panel C
4. Cowling A

Cowling

EAU3441

To remove the cowling

1. Remove panels A and B. (See page 7-7.)

2. Remove the bolts, quick fasteners and screw, and then pull the cowling outward and take it off.

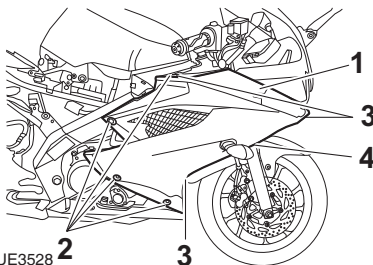

1. Cowling A
2. Bolt
3. Quick fastener
4. Screw

3. Disconnect the turn signal light lead and unhook from cowling.

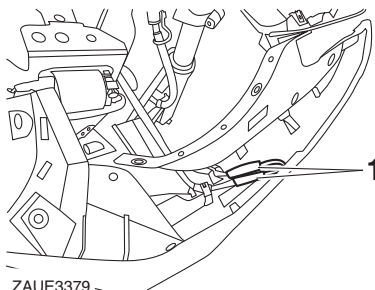

1. Turn signal light lead

To install the cowling

1. Connect and place the turn signal light leads on its original position.
2. Fit the projection on the cowling into the hole, and then push the cowling inward.

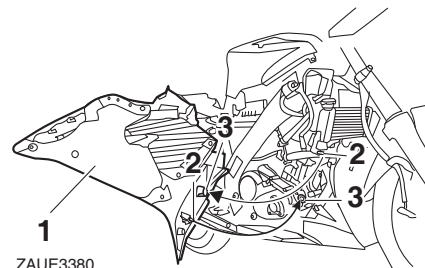

1. Cowling A
2. Projection
3. Hole

3. Install the screw, quick fasteners and bolts.
4. Install panels A and B. (See page 7-7.)

Periodic maintenance and adjustment

EAAUE3520

Panel B

Panel A

To remove the panel

Remove the four quick fasteners and one bolt for the panel, and then remove the panel.

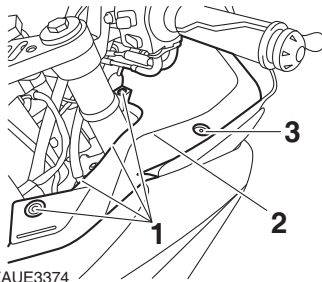

1. Quick fastener
2. Panel A
3. Bolt

To install the panel

Place the panel in the original position, and then install the bolt and quick fasteners.

To remove the panel

1. Remove the rider seat. (See page 4-16.)

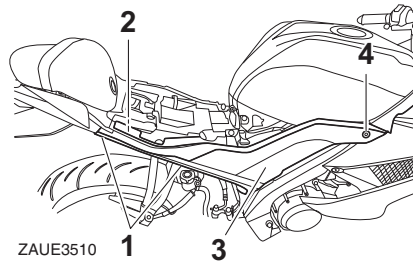

1. Quick fastener
2. Screw
3. Panel B
4. Bolt

2. Remove the quick fasteners, bolt, and screws, and then pull the panel outward and take it off.

To install the panel

1. Fit the projection on the panel into the hole, push the panel inward, and then install the screws, bolt, and quick fasteners.

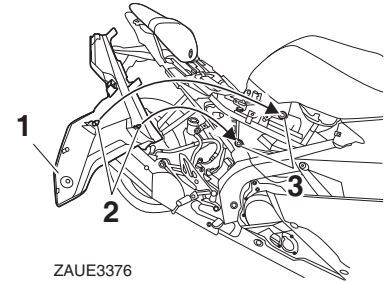

1. Panel B
2. Projection
3. Hole

2. Install the rider seat. (See page 4-16.)

Panel C

To remove the panel

1. Remove the passenger seat. (See page 4-16.)
2. Remove the bolts and screw, and then remove the panel.

Periodic maintenance and adjustment

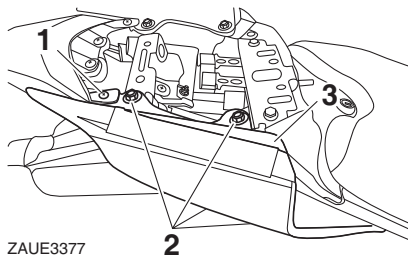

ZAUE3377

1. Screw
2. Bolt
3. Panel C

To install the panel

1. Install the panel by installing the screw and bolts.
2. Install the passenger seat. (See page 4-16.)

7

Checking the spark plug

EAU19607

The spark plug is an important engine component, which is easy to check. Since heat and deposits will cause any spark plug to slowly erode, the spark plug should be removed and checked in accordance with the periodic maintenance and lubrication chart. In addition, the condition of the spark plug can reveal the condition of the engine.

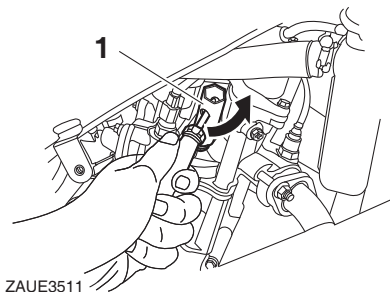

ZAUE3511

1. Spark plug wrench

To remove the spark plug

1. Remove the spark plug cap.

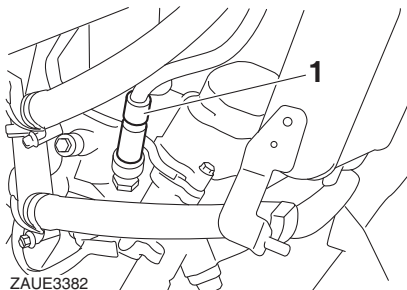

ZAUE3382

1. Spark plug cap

2. Remove the spark plug as shown, with the spark plug wrench included in the owner's tool kit.

To check the spark plug

1. Check that the porcelain insulator around the center electrode of the spark plug is a medium-to-light tan (the ideal color when the vehicle is ridden normally).

TIP

If the spark plug shows a distinctly different color, the engine could be operating improperly. Do not attempt to diagnose such problems yourself. Instead, have a Yamaha dealer check the vehicle.

Periodic maintenance and adjustment

EAUE3451

2. Check the spark plug for electrode erosion and excessive carbon or other deposits, and replace it if necessary.

Specified spark plug:
NGK/MR8E9

3. Measure the spark plug gap with a wire thickness gauge and, if necessary, adjust the gap to specification.

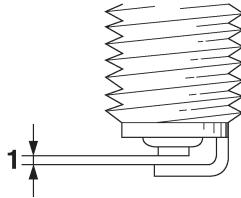

ZAUE0032

1. Spark plug cap

Spark plug gap:
0.8–0.9 mm (0.031–0.035 in)

To install the spark plug

1. Clean the surface of the spark plug gasket and its mating surface, and then wipe off any grime from the spark plug threads.
2. Install the spark plug with the spark plug wrench, and then tighten it to the specified torque.

Tightening torque:

Spark plug:
13 N·m (1.3 kgf·m, 9.6 lb·ft)

TIP

If a torque wrench is not available when installing a spark plug, a good estimate of the correct torque is 1/4–1/2 turn past finger tight. However, the spark plug should be tightened to the specified torque as soon as possible.

3. Install the spark plug cap.

Engine oil and oil filter element

The engine oil level should be checked before each ride. In addition, the oil must be changed and the oil filter element replaced at the intervals specified in the periodic maintenance and lubrication chart.

To check the engine oil level

1. Place the vehicle on a level surface and hold it in an upright position. A slight tilt to the side can result in a false reading.
2. Start the engine, warm it up for several minutes, and then turn it off.
3. Wait a few minutes until the oil settles, remove the oil filler cap, wipe the dipstick clean, insert it back into the oil filler hole (without screwing it in), and then remove it again to check the oil level.

NOTICE: Do not operate the vehicle until you know that the engine oil level is sufficient. [ECA10012]

Periodic maintenance and adjustment

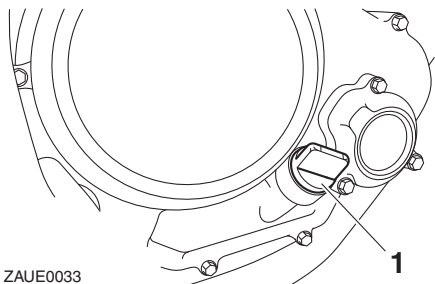

ZAUE0033

1. Engine oil filler cap

TIP

The engine oil should be between the minimum and maximum level marks.

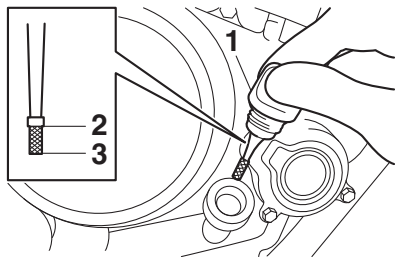

ZAUE1300

1. Dipstick
2. Maximum level mark
3. Tip of the engine oil dipstick

4. If the engine oil is below the minimum level mark, add sufficient oil of the recommended type to raise it to the correct level.
5. Install and tighten the oil filler cap.

To change the engine oil

1. Start the engine, warm it up for several minutes, and then turn it off.
2. Remove the under cover by removing the bolts, screw and quick fastener.

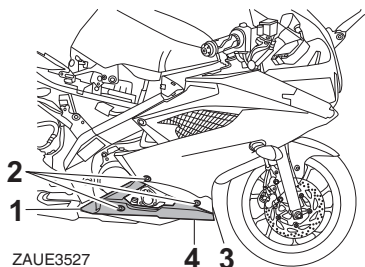

ZAUE3527

1. Cover
2. Bolt
3. Screw
4. Quick fastener

3. Place an oil pan under the engine to collect the used oil.

4. Remove the engine oil filler cap, then the drain bolt along with the O-ring, compression spring, and engine oil strainer, to drain the oil from the crankcase. **NOTICE: When removing the engine oil drain bolt, the O-ring, compression spring, and oil strainer will fall out. Take care not to lose these parts.** [ECA11002]

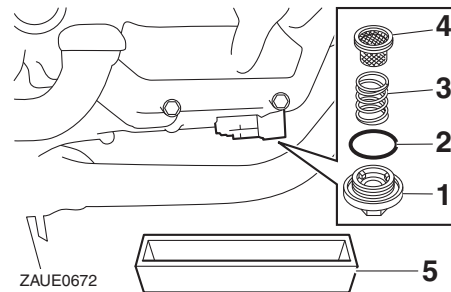

ZAUE0672

1. Engine oil drain bolt
 2. O-ring
 3. Compression spring
 4. Strainer
 5. Oil pan
5. Clean the engine oil strainer with solvent.
 6. Remove the oil filter element cover by removing the bolts.

Periodic maintenance and adjustment

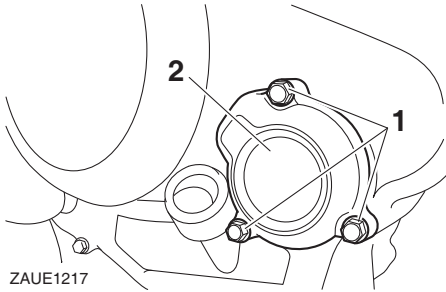

ZAUE1217

1. Bolt
2. Oil filter element cover

7. Remove and replace the oil filter element and O-ring.

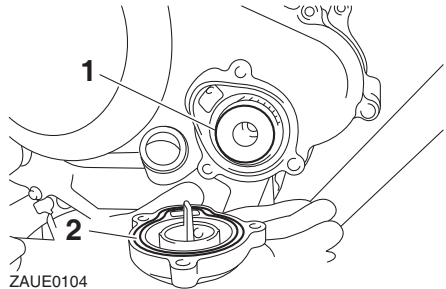

ZAUE0104

1. Oil filter element
2. O-ring

8. Install the oil filter element cover by installing the bolts, then tightening them to the specified torque.

Tightening torques:

Oil filter element cover bolt:
10 N·m (1.0 kgf·m, 7.4 lb·ft)

TIP

Make sure that the O-ring is properly seated.

9. Install the engine oil strainer, compression spring, O-ring and the engine oil drain bolt, and then tighten it to the specified torque.
NOTICE: Before installing the engine oil drain bolt, do not forget to install the O-ring, compression spring, and oil strainer in position. [ECA10422]

Tightening torques:

Engine oil drain bolt:
32 N·m (3.2 kgf·m, 24 lb·ft)

10. Refill with the specified amount of the recommended engine oil, and then install and tighten the oil filler cap.

Recommended engine oil:

See page 9-1.

Oil quantity:

Oil change:

0.85 L (0.90 US qt, 0.75 Imp.qt)

With oil filter removal:

0.95 L (1.00 US qt, 0.84 Imp.qt)

ECA11621

NOTICE

- In order to prevent clutch slippage (since the engine oil also lubricates the clutch), do not mix any chemical additives. Do not use oils with a diesel specification of “CD” or oils of a higher quality than specified. In addition, do not use oils labeled “ENERGY CONSERVING II” or higher.
- Make sure that no foreign material enters the crankcase.

Periodic maintenance and adjustment

11. Start the engine, and then let it idle for several minutes while checking it for oil leakage. If oil is leaking, immediately turn the engine off and check for the cause.
12. Turn the engine off, and then check the oil level and correct it if necessary.
13. Install the under cover by installing the bolts, screw and quick fastener.

Why Yamalube

YAMALUBE oil is a Genuine YAMAHA Part born of the engineers' passion and belief that engine oil is an important liquid engine component. We form teams of specialists in the fields of mechanical engineering, chemistry, electronics and track testing, and have them develop the engine together with the oil it will use. Yamalube oils take full advantage of the base oil's qualities and blend in the ideal balance of additives to make sure the final oil clears our performance standards. Thus, Yamalube mineral, semisynthetic and synthetic oils have their own distinct characters and value. Yamaha's experience gained over many years of research and development into oil since the 1960's helps make Yamalube the best choice for your Yamaha engine.



EAU85450

EAU20071

Coolant

The coolant level should be checked before each ride. In addition, the coolant must be changed at the intervals specified in the periodic maintenance and lubrication chart.

EAUE3460

To check the coolant level

1. Place the vehicle on a level surface.
2. Remove cowling A of left side. (See page 7-7.)
3. Hold the vehicle in an upright position.

TIP

- The coolant level must be checked on a cold engine since the level varies with engine temperature.
 - Make sure that the vehicle is positioned straight up when checking the coolant level. A slight tilt to the side can result in a false reading.
4. Check the coolant level in the coolant reservoir.

Periodic maintenance and adjustment

TIP

The coolant should be between the minimum and maximum level marks.

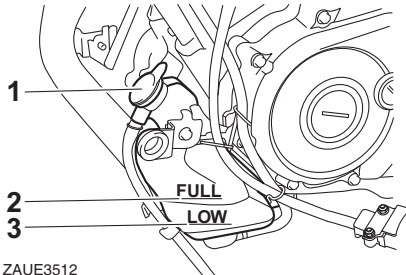

ZAUE3512

1. Coolant reservoir
2. Maximum level mark
3. Minimum level mark

5. If the coolant is at or below the minimum level mark, remove the coolant reservoir cap.

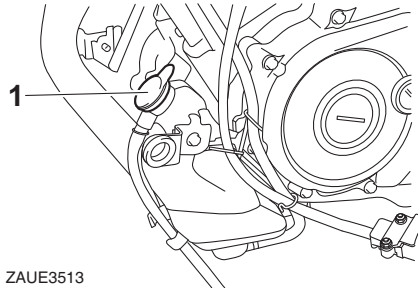

ZAUE3513

1. Coolant reservoir cap

6. Add coolant to the maximum level mark, and then install the coolant reservoir cap. **WARNING! Remove only the coolant reservoir cap. Never attempt to remove the radiator cap when the engine is hot.** ^[EWA15162] **NOTICE: If coolant is not available, use distilled water or soft tap water instead. Do not use hard water or salt water since it is harmful to the engine. If water has been used instead of coolant, replace it with coolant as soon as possible, otherwise the cooling system will not be protected against frost and corrosion. If water has been added to the**

coolant, have a Yamaha dealer check the antifreeze content of the coolant as soon as possible, otherwise the effectiveness of the coolant will be reduced.

[ECA10473]

Coolant reservoir capacity (up to the maximum level mark):

0.15 L (0.16 US qt, 0.13 Imp.qt)

7. Install the cowl.

Changing the coolant

EAU33032

The coolant must be changed at the intervals specified in the periodic maintenance and lubrication chart. Have a Yamaha dealer change the coolant. **WARNING! Never attempt to remove the radiator cap when the engine is hot.** ^[EWA10382]

Periodic maintenance and adjustment

Cleaning the air filter element EAE3640

The air filter element should be cleaned at the intervals specified in the periodic maintenance and lubrication chart. Clean the air filter element more frequently if you are riding in unusually wet or dusty areas.

1. Remove the rider seat. (See page 4-16.)
2. Remove the panel B. (See page 7-7.)
3. Remove the fuel tank bolts from both side.

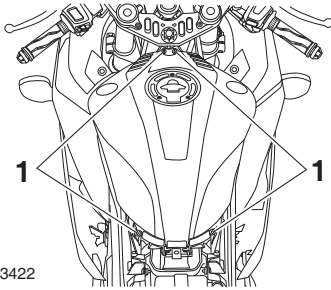

1. Bolt

4. Disconnect the fuel pump lead, fuel pump coupler, fuel hose and fuel drain hose, and then remove the fuel tank.

5. Remove the fuel hose holder from air filter case cover by pulling it outward.

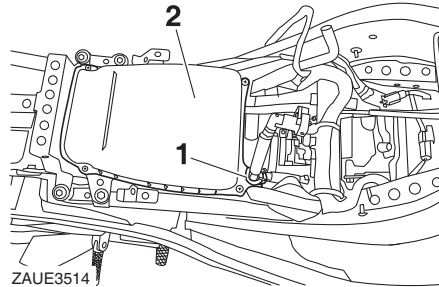

1. Fuel hose holder
2. Air filter case cover

6. Remove the air filter case cover by removing the screws.

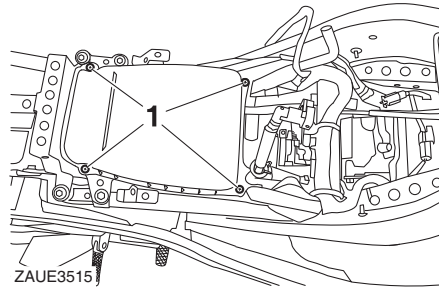

1. Screw

7. Pull the air filter element out.

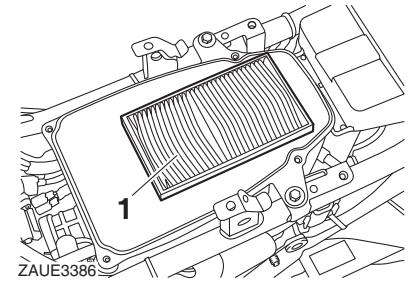

1. Air filter element

8. Lightly tap the air filter element to remove the most of the dust and dirt, and then blow the remaining dirt out with compressed air as shown. If the air filter element is damaged, replace it.

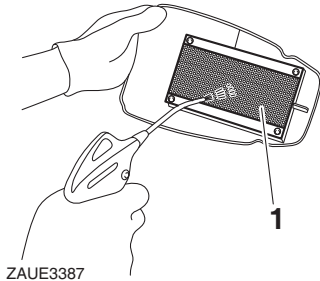

1. Air filter element

Periodic maintenance and adjustment

9. Insert the air filter element into the air filter case. **NOTICE: Make sure that the air filter element is properly seated in the air filter case. The engine should never be operated without the air filter element installed, otherwise the piston(s) and/or cylinder(s) may become excessively worn.**

[ECA10482]

10. Install the air filter case cover by installing the screws.
11. Install the fuel hose holder on it's original position.

TIP _____

If dust or water collects in the air filter check hose, remove the clamp, and then remove the plug to drain the hose.

12. Connect the fuel hose, fuel pump coupler, fuel pump lead and fuel drain hose.
13. Install the fuel tank and tighten the bolts.
14. Install the panel B.
15. Install the rider seat.

Adjusting the engine idling speed

EAU34302

The engine idling speed must be checked and, if necessary, adjusted as follows at the intervals specified in the periodic maintenance and lubrication chart.

The engine should be warm before making this adjustment.

Check the engine idling speed and, if necessary, adjust it to specification by turning the idle adjusting screw. To increase the engine idling speed, turn the screw in direction (a). To decrease the engine idling speed, turn the screw in direction (b).

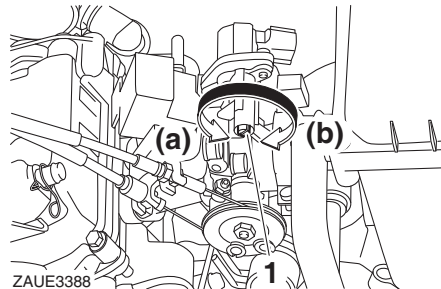

1. Idle adjusting screw

Engine idling speed:
1300–1500 r/min

TIP _____
If the specified idling speed cannot be obtained as described above, have a Yamaha dealer make the adjustment.

Periodic maintenance and adjustment

Adjusting the throttle grip free play

EAU1572

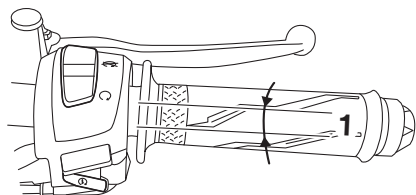

ZAUE3389

1. Throttle grip free play

The throttle grip free play should measure 3.0–5.0 mm (0.12–0.20 in) at the inner edge of the throttle grip. Periodically check the throttle grip free play and, if necessary, adjust it as follows.

TIP

The engine idling speed must be correctly adjusted before checking and adjusting the throttle grip free play.

1. Slide the rubber cover at the throttle cable.
2. Loosen the locknut.

3. To increase the throttle grip free play, turn the throttle grip free play adjusting nut in direction (a). To decrease the throttle grip free play, turn the adjusting nut in direction (b).

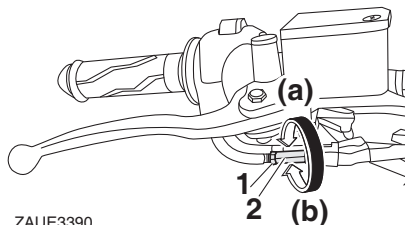

ZAUE3390

1. Locknut
2. Adjusting nut
4. Tighten the locknut.
5. Slide the rubber cover back to its original position.

EAU21403

Valve clearance

The valves are an important engine component, and since valve clearance changes with use, they must be checked and adjusted at the intervals specified in the periodic maintenance chart. Unadjusted valves can result in improper air-fuel mixture, engine noise, and eventually engine damage. To prevent this from occurring, have your Yamaha dealer check and adjust the valve clearance at regular intervals.

TIP

This service must be performed when the engine is cold.

Periodic maintenance and adjustment

Tires

EAU69760

Tires are the only contact between the vehicle and the road. Safety in all conditions of riding depends on a relatively small area of road contact. Therefore, it is essential to maintain the tires in good condition at all times and replace them at the appropriate time with the specified tires.

Tire air pressure

The tire air pressure should be checked and, if necessary, adjusted before each ride.

EWA10504

⚠ WARNING

Operation of this vehicle with improper tire pressure may cause severe injury or death from loss of control.

- The tire air pressure must be checked and adjusted on cold tires (i.e., when the temperature of the tires equals the ambient temperature).
- The tire air pressure must be adjusted in accordance with the riding speed and with the total

weight of rider, passenger, cargo, and accessories approved for this model.

Tire air pressure (measured on cold tires):

1 person:

Front:

200 kPa (2.00 kgf/cm², 29 psi)

Rear:

225 kPa (2.25 kgf/cm², 33 psi)

2 persons:

Front:

200 kPa (2.00 kgf/cm², 29 psi)

Rear:

225 kPa (2.25 kgf/cm², 33 psi)

Maximum load*:

167 kg (368 lb)

* Total weight of rider, passenger, cargo and accessories

EWA10512

⚠ WARNING

Never overload your vehicle. Operation of an overloaded vehicle could cause an accident.

Tire inspection

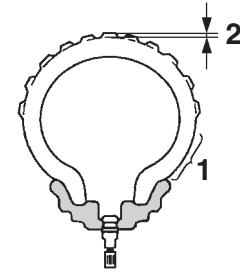

ZAUE0044

1. Tire sidewall
2. Tire tread depth

The tires must be checked before each ride. If the center tread depth reaches the specified limit, if the tire has a nail or glass fragments in it, or if the sidewall is cracked, have a Yamaha dealer replace the tire immediately.

Minimum tire tread depth (front and rear):

1.5 mm (0.06 in)

TIP

The tire tread depth limits may differ from country to country. Always comply with the local regulations.

Periodic maintenance and adjustment

EWA10472

WARNING

- **Have a Yamaha dealer replace excessively worn tires. Besides being illegal, operating the vehicle with excessively worn tires decreases riding stability and can lead to loss of control.**
- **The replacement of all wheel and brake-related parts, including the tires, should be left to a Yamaha dealer, who has the necessary professional knowledge and experience to do so.**
- **Ride at moderate speeds after changing a tire since the tire surface must first be “broken in” for it to develop its optimal characteristics.**

Tire information

This model is equipped with tubeless tires and rubber tire air valves.

Tires age, even if they have not been used or have only been used occasionally. Cracking of the tread and sidewall rubber, sometimes accompanied by carcass deformation, is an evidence of

ageing. Old and aged tires shall be checked by tire specialists to ascertain their suitability for further use.

EWA10462

WARNING

The front and rear tires should be of the same make and design, otherwise the handling characteristics of the vehicle may be different, which could lead to an accident.

After extensive tests, only the tires listed below have been approved for this model by Yamaha.

Front tire:

Size:

100/80-17M/C 52P

Manufacturer/model:

MRF/NYLOGRIP ZAPPER-FX1

Rear tire:

Size:

140/70-17M/C 66H

Manufacturer/model:

MRF/NYLOGRIP ZAPPER-S

EAU21963

Cast wheels

To maximize the performance, durability, and safe operation of your vehicle, note the following points regarding the specified wheels.

- The wheel rims should be checked for cracks, bends, warp-age or other damage before each ride. If any damage is found, have a Yamaha dealer replace the wheel. Do not attempt even the smallest repair to the wheel. A deformed or cracked wheel must be replaced.
- The wheel should be balanced whenever either the tire or wheel has been changed or replaced. An unbalanced wheel can result in poor performance, adverse handling characteristics, and a shortened tire life.

Periodic maintenance and adjustment

Adjusting the clutch lever free play EAU22047

Measure the clutch lever free play as shown.

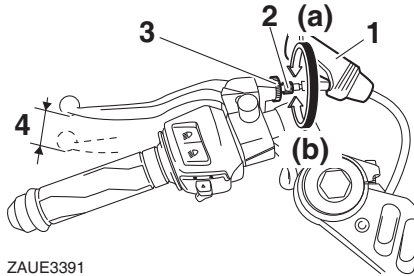

ZAU E3391

1. Rubber cover
2. Clutch lever free play adjusting bolt
3. Locknut
4. Clutch lever free play

Clutch lever free play:
10.0–15.0 mm (0.39–0.59 in)

Periodically check the clutch lever free play and, if necessary, adjust it as follows.

1. Slide the rubber cover back at the clutch lever.
2. Loosen the locknut.

3. To increase the clutch lever free play, turn the clutch lever free play adjusting bolt in direction (a). To decrease the clutch lever free play, turn the adjusting bolt in direction (b).

TIP

If the specified clutch lever free play could be obtained as described above, skip steps 4–7.

4. Fully turn the adjusting bolt at the clutch lever in direction (a) to loosen the clutch cable.
5. Loosen the locknut at the crank-case.

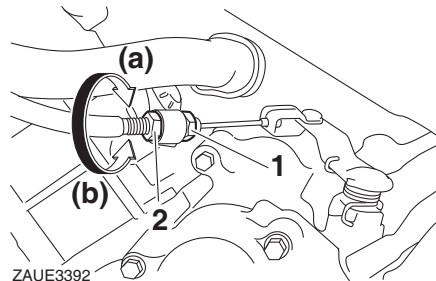

ZAU E3392

1. Locknut
2. Clutch lever free play adjusting nut

6. To increase the clutch lever free play, turn the clutch lever free play adjusting nut in direction (a). To decrease the clutch lever free play, turn the adjusting nut in direction (b).
7. Tighten the locknut at the crank-case.
8. Tighten the locknut at the clutch lever and then slide the rubber cover to its original position.

Periodic maintenance and adjustment

Checking the brake lever free play

EAU37914

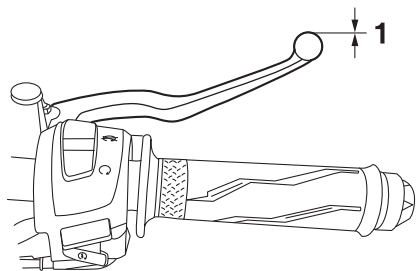

ZAUE3425

1. No brake lever free play

There should be no free play at the brake lever end. If there is free play, have a Yamaha dealer inspect the brake system.

EWA14212

⚠ WARNING

A soft or spongy feeling in the brake lever can indicate the presence of air in the hydraulic system. If there is air in the hydraulic system, have a Yamaha dealer bleed the system before operating the vehicle. Air in the hydraulic system will diminish the

braking performance, which may result in loss of control and an accident.

Brake light switches

EAU22275

The brake light is activated by switches connected to the brake lever and brake pedal. Check that the brake light comes on just before braking takes effect. If necessary, adjust the rear brake light switch as follows.

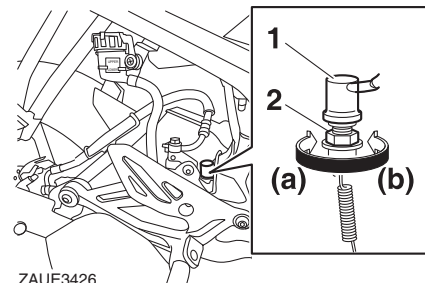

ZAUE3426

1. Brake light switch
2. Rear brake light switch adjusting nut

Turn the rear brake light switch adjusting nut while holding the rear brake light switch in place. To make the brake light come on earlier, turn the adjusting nut in direction (a). To make the brake light come on later, turn the adjusting nut in direction (b).

Periodic maintenance and adjustment

TIP _____
The front brake light switch should be serviced by a Yamaha dealer.

Checking the front and rear brake pads ^{EAU22393}

The front and rear brake pads must be checked for wear at the intervals specified in the periodic maintenance and lubrication chart.

Front brake pads

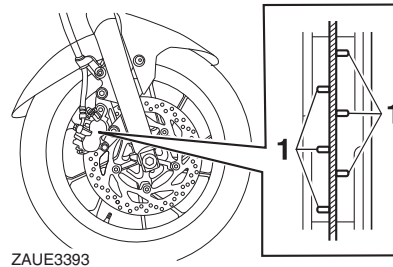

1. Brake pad wear indicator groove

Each front brake pad is provided with wear indicator grooves, which allow you to check the brake pad wear without having to disassemble the brake. To check the brake pad wear, check the wear indicator grooves. If a brake pad has worn to the point that the wear

indicator grooves have almost disappeared, have a Yamaha dealer replace the brake pads as a set.

Rear brake pads

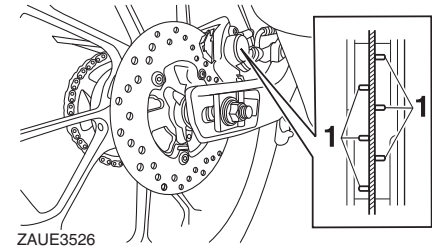

1. Brake pad wear indicator groove

Each rear brake pad is provided with wear indicator grooves, which allow you to check the brake pad wear without having to disassemble the brake. To check the brake pad wear, check the wear indicator grooves. If a brake pad has worn to the point that the wear indicator grooves have almost disappeared, have a Yamaha dealer replace the brake pads as a set.

Periodic maintenance and adjustment

Checking the brake fluid level

EAU0530

Before riding, check that the brake fluid is above the minimum level mark. Check the brake fluid level with the top of the reservoir level. Replenish the brake fluid if necessary.

Front brake

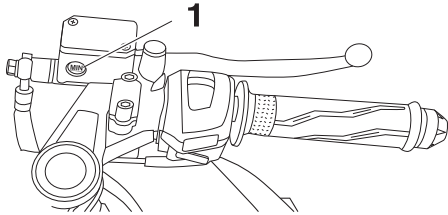

ZAUE3395

1. Minimum level mark

Rear brake

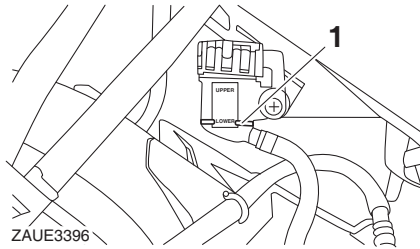

ZAUE3396

1. Minimum level mark

Specified brake fluid:
DOT 3 or DOT 4

EWA15981



WARNING

Improper maintenance can result in loss of braking ability. Observe these precautions:

- Insufficient brake fluid may allow air to enter the brake system, reducing braking performance.
- Clean the filler cap before removing. Use only DOT 3 or DOT 4 brake fluid from a sealed container.

- Use only the specified brake fluid; otherwise, the rubber seals may deteriorate, causing leakage.
- Refill with the same type of brake fluid. Adding a brake fluid other than DOT 3 or DOT 4 may result in a harmful chemical reaction.
- Be careful that water does not enter the brake fluid reservoir when refilling. Water will significantly lower the boiling point of the fluid and may result in vapor lock.

NOTICE

Brake fluid may damage painted surfaces or plastic parts. Always clean up spilled fluid immediately.

As the brake pads wear, it is normal for the brake fluid level to gradually go down. A low brake fluid level may indicate worn brake pads and/or brake system leakage; therefore, be sure to check the brake pads for wear and the brake system for leakage. If the brake

ECA17641

Periodic maintenance and adjustment

fluid level goes down suddenly, have a Yamaha dealer check the cause before further riding.

Changing the brake fluid

EAUM1362

Have a Yamaha dealer change the brake fluid at the intervals specified in the periodic maintenance and lubrication chart. In addition, have the brake hose replaced every four years and whenever it is damaged or leaking.

Drive chain slack

EAU22762

The drive chain slack should be checked before each ride and adjusted if necessary.

To check the drive chain slack

EAUE1413

1. Support the motorcycle according to the procedure on page 7-34.

TIP

When checking and adjusting the drive chain slack, there should be no weight on the motorcycle.

2. Shift the transmission into the neutral position.
3. Measure the drive chain slack as shown.

Drive chain slack:

30.0–40.0 mm (1.18–1.57 in)

Periodic maintenance and adjustment

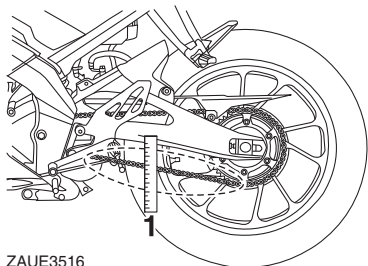

ZAU3516

1. Drive chain slack
4. If the drive chain slack is incorrect, adjust it as follows.

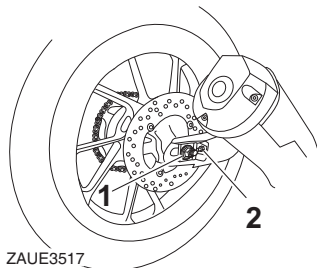

ZAU3517

1. Axle nut
2. Locknut
2. To tighten the drive chain, turn the drive chain slack adjusting bolt on each side of the swingarm in direction (a). To loosen the drive chain, turn the adjusting bolt on each side of the swingarm in direction (b), and then push the rear wheel forward. **NOTICE: Improper drive chain slack will overload the engine as well as other vital parts of the motorcycle and can lead to chain slippage or breakage. To prevent this from occurring, keep the drive chain slack within the specified limits.**

[ECA10572]

TIP

Using the alignment marks on each side of the swingarm, make sure that both drive chain pullers are in the same position for proper wheel alignment.

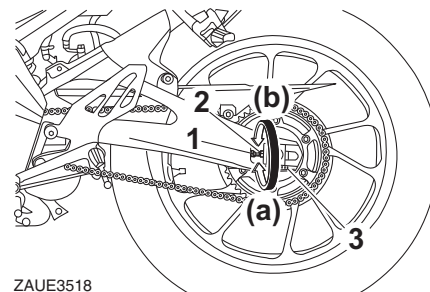

ZAU3518

1. Locknut
2. Drive chain slack adjusting bolt
3. Alignment marks
3. Tighten the axle nut, then the locknuts to their specified torques.

Tightening torques:

- Axle nut:
59 N·m (5.9 kgf·m, 44 lb·ft)
- Locknut:
16 N·m (1.6 kgf·m, 12 lb·ft)

7

To adjust the drive chain slack

EAU3431A

Consult a Yamaha dealer before adjusting the drive chain slack.

1. Loosen the axle nut and the locknut on each side of the swingarm.

Periodic maintenance and adjustment

4. Make sure that the drive chain pullers are in the same position, the drive chain slack is correct, and the drive chain moves smoothly.

Cleaning and lubricating the drive chain

EAUE0141

The drive chain must be cleaned and lubricated at the intervals specified in the periodic maintenance and lubrication chart, otherwise it will quickly wear out, especially when riding in dusty or wet areas. Service the drive chain as follows.

ECA10584

NOTICE

The drive chain must be lubricated after washing the motorcycle, riding in the rain or riding in wet areas.

1. Clean the drive chain with soap water to remove the accumulated dust & mud and then dry off.
2. Apply the cleaning spray on all the links and plates of chain, then wipe the chain. **NOTICE: To prevent damaging the O-rings, do not clean the drive chain with steam cleaners, high-pressure washers or inappropriate solvents.** [ECA11122]

3. Thoroughly lubricate the drive chain with a special O-ring chain lubricant.

Periodic maintenance and adjustment

Checking and lubricating the cables

EAUE1151

The operation of all control cables and the condition of the cables should be checked before each ride, and the cable ends should be lubricated if necessary. If a cable is damaged or does not move smoothly, have a Yamaha dealer check or replace it. **WARNING! Damage to the outer housing of cables may result in internal rusting and cause interference with cable movement. Replace damaged cables as soon as possible to prevent unsafe conditions.** [EWA10712]

Recommended lubricant:
Lithium-soap-based grease

Checking and lubricating the throttle grip and cable end

EAUE1191

The operation of the throttle grip should be checked before each ride. In addition, the cable end should be lubricated by a Yamaha dealer at the intervals specified in the periodic maintenance chart.

The throttle cable is equipped with a rubber cover. Make sure that the cover is securely installed. Even though the cover is installed correctly, it does not completely protect the cable from water entry. Therefore, use care not to pour water directly onto the cover or cable when washing the vehicle. If the cable or cover becomes dirty, wipe clean with a moist cloth.

Checking and lubricating the brake and shift pedals

EAU44276

The operation of the brake and shift pedals should be checked before each ride, and the pedal pivots should be lubricated if necessary.

Brake pedal

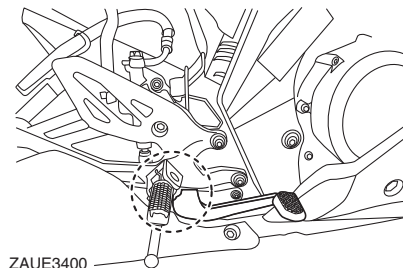

ZAUE3400

Shift pedal

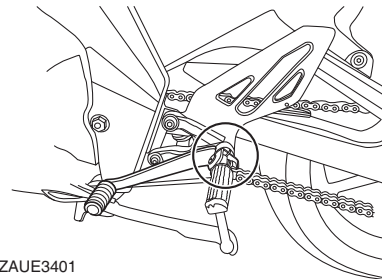

ZAUE3401

Periodic maintenance and adjustment

Recommended lubricant:
Lithium-soap-based grease

Checking and lubricating the ^{EAU23144} brake and clutch levers

The operation of the brake and clutch levers should be checked before each ride, and the lever pivots should be lubricated if necessary.

Recommended lubricants:
Brake lever:
Silicone grease
Clutch lever:
Lithium-soap-based grease

Brake lever

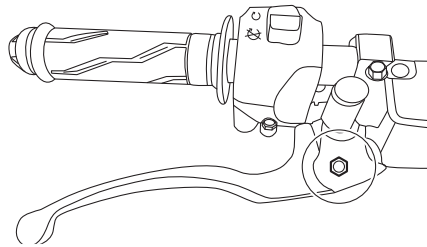

ZAUE3402

Clutch lever

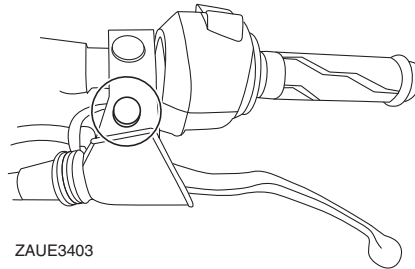

ZAUE3403

Periodic maintenance and adjustment

Checking and lubricating the sidestand

EAU23203

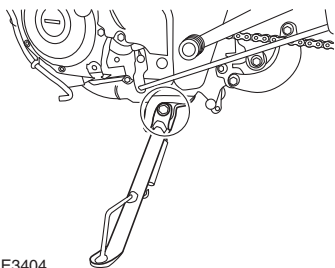

ZAUE3404

The operation of the sidestand should be checked before each ride, and the sidestand pivot and metal-to-metal contact surfaces should be lubricated if necessary.

WARNING

If the sidestand does not move up and down smoothly, have a Yamaha dealer check or repair it. Otherwise, the sidestand could contact the ground and distract the operator, resulting in a possible loss of control.

Recommended lubricant:
Lithium-soap-based grease

Lubricating the swingarm pivots

EAUM1653

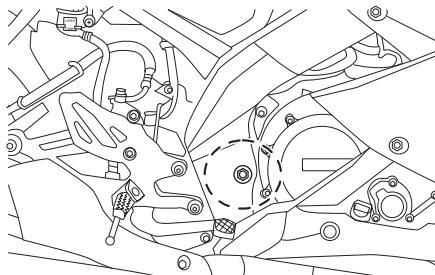

ZAUE3405

The swingarm pivots must be lubricated by a Yamaha dealer at the intervals specified in the periodic maintenance and lubrication chart.

Recommended lubricant:
Lithium-soap-based grease

Checking the front fork

EAU23273

The condition and operation of the front fork must be checked as follows at the intervals specified in the periodic maintenance and lubrication chart.

To check the condition

Check the inner tubes for scratches, damage and excessive oil leakage.

To check the operation

1. Place the vehicle on a level surface and hold it in an upright position. **WARNING! To avoid injury, securely support the vehicle so there is no danger of it falling over.** [EWA10752]
2. While applying the front brake, push down hard on the handlebars several times to check if the front fork compresses and rebounds smoothly.

Periodic maintenance and adjustment

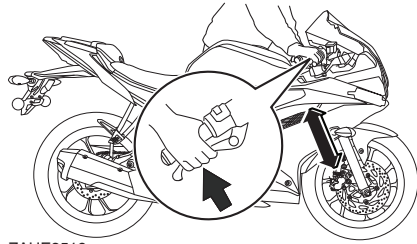

ZAUE3519

ECA10591

NOTICE

If any damage is found or the front fork does not operate smoothly, have a Yamaha dealer check or repair it.

Checking the steering

EAU23285

Worn or loose steering bearings may cause danger. Therefore, the operation of the steering must be checked as follows at the intervals specified in the periodic maintenance and lubrication chart.

1. Raise the front wheel off the ground. (See page 7-34.)
WARNING! To avoid injury, securely support the vehicle so there is no danger of it falling over. [EWA10752]
2. Hold the lower ends of the front fork legs and try to move them forward and backward. If any free play can be felt, have a Yamaha dealer check or repair the steering.

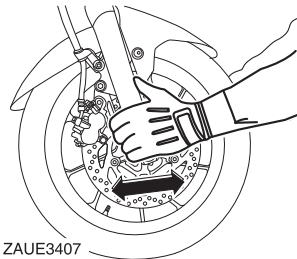

ZAUE3407

Checking the wheel bearings

EAU23292

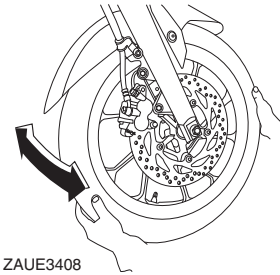

ZAUE3408

The front and rear wheel bearings must be checked at the intervals specified in the periodic maintenance and lubrication chart. If there is play in the wheel hub or if the wheel does not turn smoothly, have a Yamaha dealer check the wheel bearings.

Periodic maintenance and adjustment

Battery

EAU23377

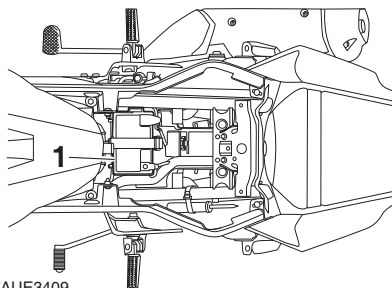

ZAUE3409

1. Battery

This model is equipped with a VRLA (Valve Regulated Lead Acid) battery. There is no need to check the electrolyte or to add distilled water. However, the battery lead connections need to be checked and, if necessary, tightened.

EWA10761

WARNING

- **Electrolyte is poisonous and dangerous since it contains sulfuric acid, which causes severe burns. Avoid any contact with skin, eyes or clothing and always shield your eyes when**

working near batteries. In case of contact, administer the following **FIRST AID**.

- **EXTERNAL:** Flush with plenty of water.
- **INTERNAL:** Drink large quantities of water or milk and immediately call a physician.
- **EYES:** Flush with water for 15 minutes and seek prompt medical attention.
- **Batteries produce explosive hydrogen gas. Therefore, keep sparks, flames, cigarettes, etc., away from the battery and provide sufficient ventilation when charging it in an enclosed space.**
- **KEEP THIS AND ALL BATTERIES OUT OF THE REACH OF CHILDREN.**

NOTICE

Never attempt to remove the battery cell seals, as this would permanently damage the battery.

ECA10621

To charge the battery

Have a Yamaha dealer charge the battery as soon as possible if it seems to have discharged. Keep in mind that the battery tends to discharge more quickly if the vehicle is equipped with optional electrical accessories.

ECA16522

NOTICE

To charge a VRLA (Valve Regulated Lead Acid) battery, a special (constant-voltage) battery charger is required. Using a conventional battery charger will damage the battery.

To store the battery

1. If the vehicle will not be used for more than one month, remove the battery, fully charge it, and then place it in a cool, dry place. **NOTICE:** When removing the battery, be sure to turn the main switch off, then disconnect the negative lead before disconnecting the positive lead. [ECA16304]
2. If the battery will be stored for more than two months, check it at least once a month and fully charge it if necessary.

Periodic maintenance and adjustment

3. Fully charge the battery before installation. **NOTICE:** When installing the battery, be sure to turn the main switch off, then connect the positive lead before connecting the negative lead.

[ECA16842]

4. After installation, make sure that the battery leads are properly connected to the battery terminals.

ECA16531

NOTICE

Always keep the battery charged. Storing a discharged battery can cause permanent battery damage.

Replacing the fuses

EAU53044

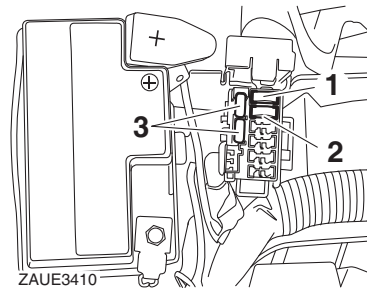

1. Main fuse
2. Accessory fuse
3. Spare fuse

The fuse box is located under the rider seat. (See page 4-16.)

If a fuse is blown, replace it as follows.

1. Turn the main switch off and turn off the electrical circuit in question.
2. Remove the blown fuse, and then install a new fuse of the specified amperage. **WARNING! Do not use a fuse of a higher amperage rating than recommended to avoid causing extensive damage to the electrical system and possibly a fire.** [EWA15132]

Specified fuses:

Main fuse:

15.0 A

Accessory fuse:

2.0 A

3. Turn the main switch on and turn on the electrical circuit in question to check if the device operates.
4. If the fuse immediately blows again, have a Yamaha dealer check the electrical system.

Periodic maintenance and adjustment

Vehicle lights

This model is equipped with LED lights for headlights, auxiliary lights and brake/tail light. If a light does not come on, check the fuse and then have a Yamaha dealer check the vehicle.

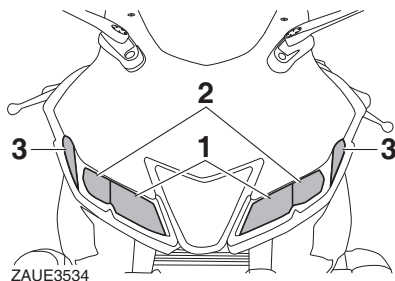

ZAUE3534

1. Headlight (low beam)
2. Headlight (high beam)
3. Auxiliary light

EAUN2261

NOTICE

Do not affix any type of tinted film or stickers to the headlight lens.

ECA16581

Replacing a turn signal light bulb

EAU24205

1. Remove the turn signal light lens by removing the screw.

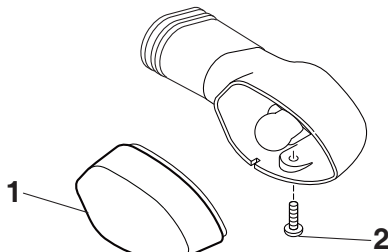

ZAUE3327

1. Turn signal light lens
2. Screw

2. Remove the burnt-out bulb by pushing it in and turning it counterclockwise.

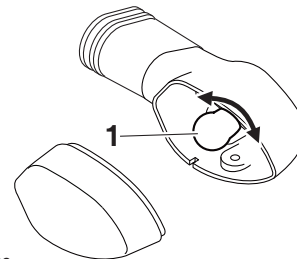

ZAUE3328

1. Bulb

3. Insert a new bulb into the socket, push it in, and then turn it clockwise until it stops.
4. Install the lens by installing the screw. **NOTICE: Do not over-tighten the screw, otherwise the lens may break.** [ECA11192]

Periodic maintenance and adjustment

Supporting the motorcycle

EAU24351

Since this model is not equipped with a centerstand, follow these precautions when removing the front and rear wheel or performing other maintenance requiring the motorcycle to stand upright. Check that the motorcycle is in a stable and level position before starting any maintenance. A strong wooden box can be placed under the engine for added stability.

To service the front wheel

1. Stabilize the rear of the motorcycle by using a motorcycle stand or, if an additional motorcycle stand is not available, by placing a jack under the frame in front of the rear wheel.
2. Raise the front wheel off the ground by using a motorcycle stand.

To service the rear wheel

Raise the rear wheel off the ground by using a motorcycle stand or, if a motorcycle stand is not available, by placing

a jack either under each side of the frame in front of the rear wheel or under each side of the swingarm.

Front wheel

EAU24361

EAUN0582

To remove the front wheel

EWA10822



WARNING

To avoid injury, securely support the vehicle so there is no danger of it falling over.

1. Loosen the front wheel axle nut and the brake caliper bolts.

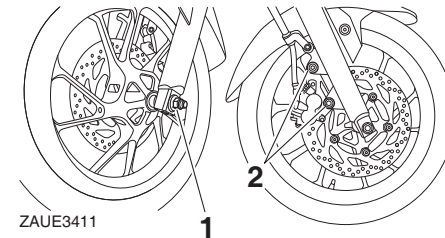

ZAUE3411

1. Axle nut
2. Brake caliper bolt

Periodic maintenance and adjustment

2. Lift the front wheel off the ground according to the procedure in the previous section “Supporting the motorcycle”.
3. Remove the brake hose holder by removing the bolt.
4. Remove the brake caliper by removing the bolts.

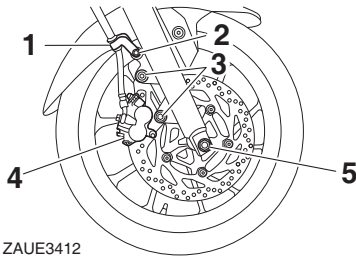

ZAUE3412

1. Brake hose holder
2. Bolt
3. Brake caliper
4. Brake caliper bolt
5. Wheel axle

5. Remove the front wheel axle nut.
6. Pull the wheel axle out, and then remove the wheel. **NOTICE: Do not apply the brake after the**

brake calipers have been removed, otherwise the brake pads will be forced shut. [ECA11052]

To install the front wheel

1. Lift the wheel up between the fork legs.
2. Insert the wheel axle and install the wheel axle nut.
3. Lower the front wheel so that it is on the ground.
4. Install the brake caliper by installing the bolts.

TIP

Make sure that there is enough space between the brake pads before installing the brake caliper onto the brake disc.

5. Install the brake hose holder by installing the bolt.
6. Tighten the wheel axle and brake caliper bolts to the specified torques.

Tightening torques:

Wheel axle:

38 N·m (3.8 kgf·m, 28 lb·ft)

Brake caliper bolt:

35 N·m (3.5 kgf·m, 26 lb·ft)

7. Push down hard on the handlebar several times to check for proper fork operation.

Periodic maintenance and adjustment

Rear wheel

EAU25081

EAU3620

EWA10822

To remove the rear wheel



WARNING

To avoid injury, securely support the vehicle so there is no danger of it falling over.

1. Remove the drive chain case by removing the bolts along with the collar.

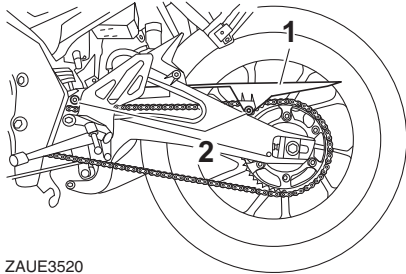

ZAUE3520

1. Drive chain case
2. Bolt

2. Loosen the axle nut.

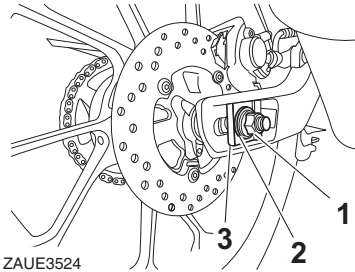

ZAUE3524

1. Axle nut
2. Washer
3. Drive chain puller

3. Lift the rear wheel off the ground according to the procedure on page 7-34.
4. Remove the axle nut along with the washer and drive chain puller.
5. Fully loosen the drive chain slack adjuster locknut on each side of the swingarm.
6. Turn the drive chain slack adjusting bolts fully in direction (a) and push the wheel forward.

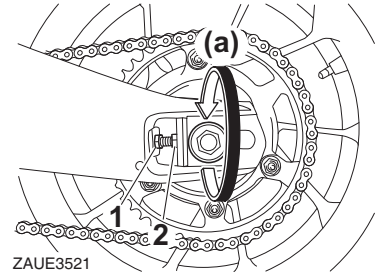

ZAUE3521

1. Locknut
2. Drive chain slack adjusting bolt

7. Remove the drive chain from the rear sprocket.

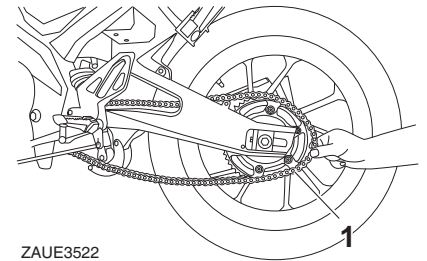

ZAUE3522

1. Drive chain

Periodic maintenance and adjustment

TIP

- If the drive chain is difficult to remove, remove the wheel axle first, and then lift the wheel upward enough to remove the drive chain from the rear sprocket.
- The drive chain does not need to be disassembled in order to remove and install the wheel.

8. While supporting the brake caliper bracket, pull the wheel axle out along with the washer and chain puller, and then remove the wheel. **NOTICE: Do not apply the brake after the wheel and brake disc have been removed, otherwise the brake pads will be forced shut.** [ECA11073]

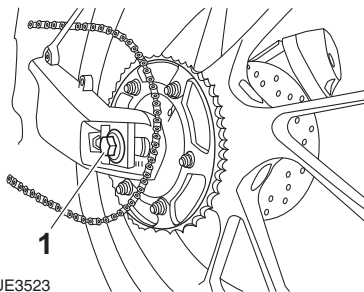

ZAUE3523

1. Wheel axle

To install the rear wheel

1. Install the wheel and the brake caliper bracket by inserting the wheel axle along with the washer and drive chain puller from the left-hand side.

TIP

- Be sure to insert the retainer on the brake caliper bracket into the slot in the swingarm.
- Make sure that there is enough space between the brake pads before installing the wheel.

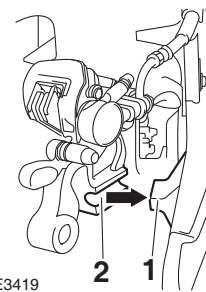

ZAUE3419

1. Retainer
2. Slot

2. Install the drive chain onto the rear sprocket.
3. Install the drive chain puller and axle nut along with the washer, and then adjust the drive chain slack. (See page 7-24.)
4. Lower the rear wheel so that it is on the ground, and then put the sidestand down.
5. Tighten the axle nut, and then tighten the chain adjuster locknuts to the specified torques.

Tightening torques:

Axle nut:

59 N·m (5.9 kgf·m, 44 lb·ft)

Locknut:

16 N·m (1.6 kgf·m, 12 lb·ft)

6. Install the drive chain case by installing the bolts along with the collar.

Tightening torques:

Drive chain case bolt:

7 N·m (0.7 kgf·m, 5.2 lb·ft)

Troubleshooting

EAU25872

Although Yamaha motorcycles receive a thorough inspection before shipment from the factory, trouble may occur during operation. Any problem in the fuel, compression, or ignition systems, for example, can cause poor starting and loss of power.

The following troubleshooting charts represent quick and easy procedures for checking these vital systems yourself. However, should your motorcycle require any repair, take it to a Yamaha dealer, whose skilled technicians have the necessary tools, experience, and know-how to service the motorcycle properly.

Use only genuine Yamaha replacement parts. Imitation parts may look like Yamaha parts, but they are often inferior, have a shorter service life and can lead to expensive repair bills.

EWA15142

WARNING

When checking the fuel system, do not smoke, and make sure there are no open flames or sparks in the area, including pilot lights from water

heaters or furnaces. Gasoline or gasoline vapors can ignite or explode, causing severe injury or property damage.

Periodic maintenance and adjustment

EAU42136

Troubleshooting charts

Starting problems or poor engine performance

1. Fuel

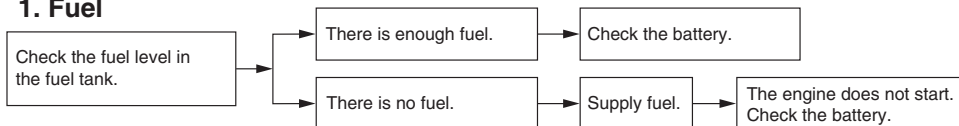

2. Battery

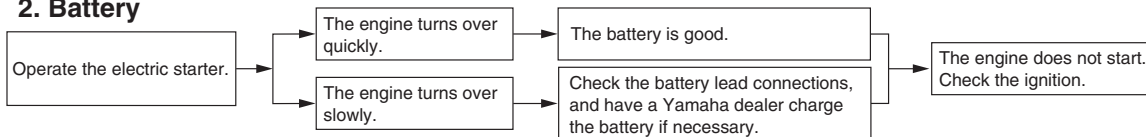

3. Ignition

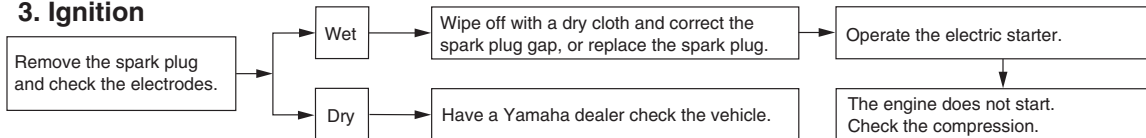

4. Compression

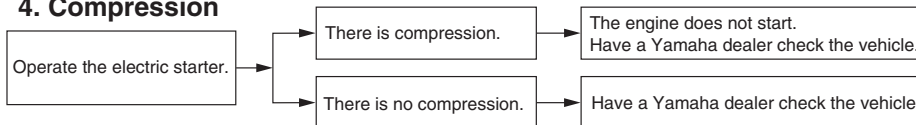

Periodic maintenance and adjustment

Engine overheating

EWA10401

WARNING

- Do not remove the radiator cap when the engine and radiator are hot. Scalding hot fluid and steam may be blown out under pressure, which could cause serious injury. Be sure to wait until the engine has cooled.
- After removing the radiator cap retaining bolt, place a thick rag, like a towel, over the radiator cap, and then slowly rotate the cap counterclockwise to the detent to allow any residual pressure to escape. When the hissing sound has stopped, press down on the cap while turning it counterclockwise, and then remove the cap.

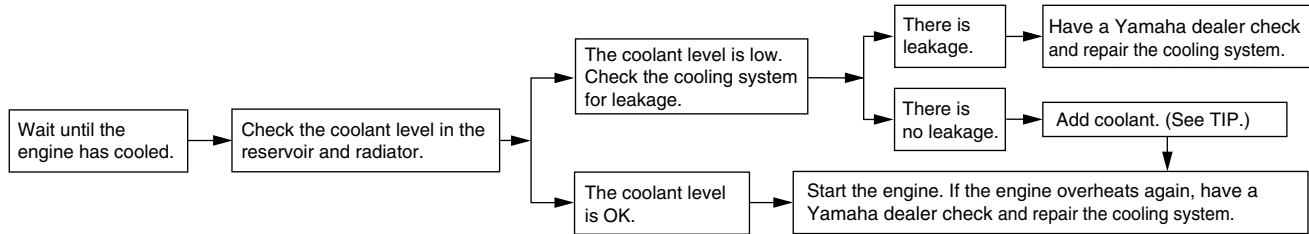

TIP

If coolant is not available, tap water can be temporarily used instead, provided that it is changed to the recommended coolant as soon as possible.

Motorcycle care and storage

Matte color caution

EAU37834

ECA15193

NOTICE

Some models are equipped with matte colored finished parts. Be sure to consult a Yamaha dealer for advice on what products to use before cleaning the vehicle. Using a brush, harsh chemical products or cleaning compounds when cleaning these parts will scratch or damage their surface. Wax also should not be applied to any matte colored finished parts.

Care

EAU57020

While the open design of a motorcycle reveals the attractiveness of the technology, it also makes it more vulnerable. Rust and corrosion can develop even if high-quality components are used. A rusty exhaust pipe may go unnoticed on a car, however, it detracts from the overall appearance of a motorcycle. Frequent and proper care does not only comply with the terms of the warranty, but it will also keep your motorcycle looking good, extend its life and optimize its performance.

Before cleaning

1. Cover the muffler outlet with a plastic bag after the engine has cooled down.
2. Make sure that all caps and covers as well as all electrical couplers and connectors, including the spark plug cap, are tightly installed.
3. Remove extremely stubborn dirt, like oil burnt onto the crankcase, with a degreasing agent and a brush, but never apply such prod-

ucts onto seals, gaskets, sprockets, the drive chain and wheel axles. Always rinse the dirt and degreaser off with water.

Cleaning

ECA10773

NOTICE

- **Avoid using strong acidic wheel cleaners, especially on spoked wheels. If such products are used on hard-to-remove dirt, do not leave the cleaner on the affected area any longer than instructed. Also, thoroughly rinse the area off with water, immediately dry it, and then apply a corrosion protection spray.**
- **Improper cleaning can damage plastic parts (such as cowlings, panels, windshields, headlight lenses, meter lenses, etc.) and the mufflers. Use only a soft, clean cloth or sponge with water to clean plastic. However, if the plastic parts cannot be thoroughly cleaned with water, diluted mild detergent with water may be used. Be sure to rinse**

off any detergent residue using plenty of water, as it is harmful to plastic parts.

- Do not use any harsh chemical products on plastic parts. Be sure to avoid using cloths or sponges which have been in contact with strong or abrasive cleaning products, solvent or thinner, fuel (gasoline), rust removers or inhibitors, brake fluid, antifreeze or electrolyte.
- Do not use high-pressure washers or steam-jet cleaners since they cause water seepage and deterioration in the following areas: seals (of wheel and swing-arm bearings, fork and brakes), electric components (couplers, connectors, instruments, switches and lights), breather hoses and vents.
- For motorcycles equipped with a windshield: Do not use strong cleaners or hard sponges as they will cause dulling or scratching. Some cleaning compounds for plastic may leave scratches on the wind-

shield. Test the product on a small hidden part of the windshield to make sure that it does not leave any marks. If the windshield is scratched, use a quality plastic polishing compound after washing.

After normal use

Remove dirt with warm water, a mild detergent, and a soft, clean sponge, and then rinse thoroughly with clean water. Use a toothbrush or bottlebrush for hard-to-reach areas. Stubborn dirt and insects will come off more easily if the area is covered with a wet cloth for a few minutes before cleaning.

After riding in the rain, near the sea or on salt-sprayed roads

Since sea salt or salt sprayed on roads during winter are extremely corrosive in combination with water, carry out the following steps after each ride in the rain, near the sea or on salt-sprayed roads.

TIP

Salt sprayed on roads in the winter may remain well into spring.

1. Clean the motorcycle with cold water and a mild detergent, after the engine has cooled down. **NOTICE: Do not use warm water since it increases the corrosive action of the salt.**^[ECA10792]
2. Apply a corrosion protection spray on all metal, including chrome- and nickel-plated, surfaces to prevent corrosion.

Cleaning the windshield

Avoid using any alkaline or strong acid cleaner, gasoline, brake fluid, or any other solvent. Clean the windshield with a cloth or sponge dampened with a mild detergent, and then wash it off thoroughly with water. For additional cleaning, use Yamaha Windshield Cleaner or another high-quality windshield cleaner. Some cleaning compounds for plastics may leave scratches on the windshield. Before using such cleaners, test an area of the

Motorcycle care and storage

windshield which does not affect your visibility and which cannot be easily recognized.

After cleaning

1. Dry the motorcycle with a chamois or an absorbing cloth.
2. Immediately dry the drive chain and lubricate it to prevent it from rusting.
3. Use a chrome polish to shine chrome, aluminum and stainless-steel parts, including the exhaust system. (Even the thermally induced discoloring of stainless-steel exhaust systems can be removed through polishing.)
4. To prevent corrosion, it is recommended to apply a corrosion protection spray on all metal, including chrome- and nickel-plated, surfaces.
5. Use spray oil as a universal cleaner to remove any remaining dirt.
6. Touch up minor paint damage caused by stones, etc.
7. Wax all painted surfaces.
8. Let the motorcycle dry completely before storing or covering it.



EWA11132

Contaminants on the brakes or tires can cause loss of control.

- **Make sure that there is no oil or wax on the brakes or tires.**
- **If necessary, clean the brake discs and brake linings with a regular brake disc cleaner or acetone, and wash the tires with warm water and a mild detergent. Before riding at higher speeds, test the motorcycle's braking performance and cornering behavior.**

ECA10801

NOTICE

- **Apply spray oil and wax sparingly and make sure to wipe off any excess.**
- **Never apply oil or wax to any rubber and plastic parts, but treat them with a suitable care product.**
- **Avoid using abrasive polishing compounds as they will wear away the paint.**

TIP

- Consult a Yamaha dealer for advice on what products to use.
- Washing, rainy weather or humid climates can cause the headlight lens to fog. Turning the headlight on for a short period of time will help remove the moisture from the lens.

Storage

EAU43204

Short-term

Always store your motorcycle in a cool, dry place and, if necessary, protect it against dust with a porous cover. Be sure the engine and the exhaust system are cool before covering the motorcycle.

ECA10811

NOTICE

- **Storing the motorcycle in a poorly ventilated room or covering it with a tarp, while it is still wet, will allow water and humidity to seep in and cause rust.**
- **To prevent corrosion, avoid damp cellars, stables (because of the presence of ammonia) and areas where strong chemicals are stored.**

Long-term

Before storing your motorcycle for several months:

1. Follow all the instructions in the “Care” section of this chapter.

2. Fill up the fuel tank and add fuel stabilizer (if available) to prevent the fuel tank from rusting and the fuel from deteriorating.
3. Perform the following steps to protect the cylinder, piston rings, etc. from corrosion.
 - a. Remove the spark plug cap and spark plug.
 - b. Pour a teaspoonful of engine oil into the spark plug bore.
 - c. Install the spark plug cap onto the spark plug, and then place the spark plug on the cylinder head so that the electrodes are grounded. (This will limit sparking during the next step.)
 - d. Turn the engine over several times with the starter. (This will coat the cylinder wall with oil.)
WARNING! To prevent damage or injury from sparking, make sure to ground the spark plug electrodes while turning the engine over.
4. Lubricate all control cables and the pivoting points of all levers and pedals as well as of the side-stand/centerstand.
5. Check and, if necessary, correct the tire air pressure, and then lift the motorcycle so that both of its wheels are off the ground. Alternatively, turn the wheels a little every month in order to prevent the tires from becoming degraded in one spot.
6. Cover the muffler outlet with a plastic bag to prevent moisture from entering it.
7. Remove the battery and fully charge it. Store it in a cool, dry place and charge it once a month. Do not store the battery in an excessively cold or warm place [less than 0 °C (30 °F) or more than 30 °C (90 °F)]. For more information on storing the battery, see page 7-31.
- e. Remove the spark plug cap from the spark plug, and then install the spark plug and the spark plug cap.

[EWA10952]

Motorcycle care and storage

TIP _____

Make any necessary repairs before storing the motorcycle.

Dimensions:

- Overall length:
1990 mm (78.3 in)
- Overall width:
725 mm (28.5 in)
- Overall height:
1135 mm (44.7 in)
- Seat height:
815 mm (32.1 in)
- Wheelbase:
1325 mm (52.2 in)
- Ground clearance:
170 mm (6.69 in)
- Minimum turning radius:
2.8 m (9.19 ft)

Weight:

- Curb weight:
138 kg (304 lb)

Engine:

- Combustion cycle:
4-stroke
- Cooling system:
Liquid cooled
- Valve train:
SOHC
- Number of cylinders:
Single cylinder
- Displacement:
155 cm³
- Bore × stroke:
58.0 × 58.7 mm (2.28 × 2.31 in)
- Starting system:
Electric starter

Engine oil:

Recommended brand:



SAE viscosity grades:
10W-40

Recommended engine oil grade:
API service SG type or higher, JASO
standard MA

Engine oil quantity:

Oil change:
0.85 L (0.90 US qt, 0.75 Imp.qt)

With oil filter removal:
0.95 L (1.00 US qt, 0.84 Imp.qt)

Coolant quantity:

Coolant reservoir (up to the maximum level
mark):

0.15 L (0.16 US qt, 0.13 Imp.qt)

Radiator (including all routes):

0.49 L (0.52 US qt, 0.43 Imp.qt)

Fuel:

- Recommended fuel:
Regular unleaded gasoline only
- Fuel tank capacity:
11 L (2.9 US gal, 2.4 Imp.gal)
- Fuel reserve amount:
1.9 L (0.50 US gal, 0.42 Imp.gal)

Fuel injection:

- Throttle body:
- ID mark:
B1P1 00

Drivetrain:

- Gear ratio:
1st:
2.833 (34/12)
- 2nd:
1.875 (30/16)
- 3rd:
1.364 (30/22)
- 4th:
1.143 (24/21)
- 5th:
0.957 (22/23)
- 6th:
0.840 (21/25)

Front tire:

- Type:
Tubeless
- Size:
100/80-17M/C 52P
- Manufacturer/model:
MRF/NYLOGRIP ZAPPER-FX1

Rear tire:

- Type:
Tubeless
- Size:
140/70-17M/C 66H
- Manufacturer/model:
MRF/NYLOGRIP ZAPPER-S

Loading:

- Maximum load:
167 kg (368 lb)
(Total weight of rider, passenger, cargo
and accessories)

Specifications

Front brake:

Type:

Hydraulic single disc brake

Rear brake:

Type:

Hydraulic single disc brake

Front suspension:

Type:

Telescopic fork

Rear suspension:

Type:

Swingarm (link suspension)

Electrical system:

System voltage:

12 V

Battery:

Model:

YTZ6V

Voltage, capacity:

12 V, 5.0 Ah (10 HR)

Bulb wattage:

Headlight:

LED

Brake/tail light:

LED

Front turn signal light:

10.0 W

Rear turn signal light:

10.0 W

Auxiliary light:

LED

License plate light:

5.0 W

Identification numbers

EAU53562

Record the vehicle identification number, engine serial number, and the model label information in the spaces provided below. These identification numbers are needed when registering the vehicle with the authorities in your area and when ordering spare parts from a Yamaha dealer.

VEHICLE IDENTIFICATION NUMBER:

ENGINE SERIAL NUMBER:

MODEL LABEL INFORMATION:

Vehicle identification number

EAU26401

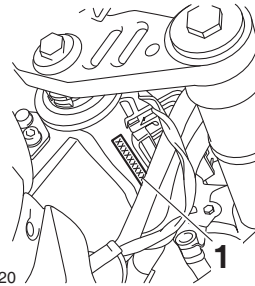

ZAUE3420

1. Vehicle identification number

The vehicle identification number is stamped into the steering head pipe. Record this number in the space provided.

TIP

The vehicle identification number is used to identify your motorcycle and may be used to register your motorcycle with the licensing authority in your area.

Engine serial number

EAU26442

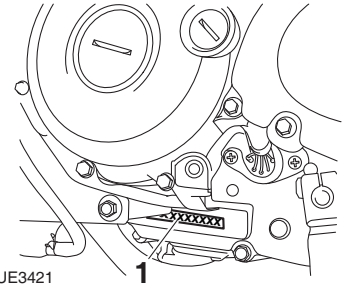

ZAUE3421

1. Engine serial number

The engine serial number is stamped into the crankcase.

Model label

EAU26471

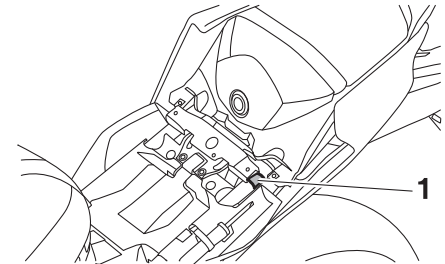

ZAUE3525

1. Model label

Consumer information

The model label is affixed to the frame under the rider seat. (See page 4-16.) Record the information on this label in the space provided. This information will be needed when ordering spare parts from a Yamaha dealer.

Motorcycle noise regulation **(for Australia)**

EAU26571

TAMPERING WITH NOISE CONTROL SYSTEM PROHIBITED:

Owners are warned that the law may prohibit:

- a. The removal or rendering inoperative by any person other than for purposes of maintenance, repair or replacement, of any device or element of design incorporated into any new vehicle for the purpose of noise control prior to its sale or delivery to the ultimate purchaser or while it is in use; and
- b. The use of the vehicle after such device or element of design has been removed or rendered inoperative by any person.

- A**
 Air filter element, cleaning 7-15
- B**
 Battery 7-31
 Brake and clutch levers,
 checking and lubricating 7-28
 Brake and shift pedals,
 checking and lubricating 7-27
 Brake fluid, changing 7-24
 Brake fluid level, checking 7-23
 Brake lever 4-12
 Brake lever free play, checking 7-21
 Brake light switches 7-21
 Brake pedal 4-13
- C**
 Cables, checking and lubricating 7-27
 Care 8-1
 Catalytic converter 4-15
 Clutch lever 4-12
 Clutch lever free play, adjusting 7-20
 Coolant 7-13
 Coolant temperature warning light 4-2
 Cowling and panels,
 removing and installing 7-7
- D**
 Dimmer/Pass switch 4-11
 Drive chain, cleaning and lubricating ... 7-26
 Drive chain slack 7-24
- E**
 Engine break-in 6-3
 Engine idling speed 7-16
 Engine oil and oil filter element 7-10
 Engine serial number 10-1
 Engine stop switch 4-11
- Engine trouble warning light 4-3
- F**
 Front and rear brake pads, checking... 7-22
 Front fork, checking 7-29
 Fuel 4-14
 Fuel consumption, tips for reducing 6-2
 Fuel tank cap 4-13
 Fuses, replacing 7-32
- H**
 Handlebar switches 4-11
 Helmet holder 4-17
 High beam indicator light 4-2
 Horn switch 4-11
- I**
 Identification numbers 10-1
 Ignition circuit cut-off system 4-18
 Indicator lights and warning lights 4-2
- L**
 Labels, location 1-1
- M**
 Main switch/steering lock 4-1
 Maintenance and lubrication, periodic... 7-3
 Maintenance, emission control
 system 7-2
 Matte color, caution 8-1
 Model label 10-1
 Multi-function meter unit 4-3
- N**
 Neutral indicator light 4-2
 Noise regulation (for Australia) 10-2
- P**
 Parking 6-3
 Part locations 3-1
- S**
 Safe-riding points 2-5
 Safety information 2-1
 Seats 4-16
 Shifting 6-2
 Shift pedal 4-12
 Shift timing indicator light 4-3
 Sidestand 4-18
 Sidestand, checking and lubricating ... 7-29
 Spark plug, checking 7-9
 Specifications 9-1
 Starting the engine 6-1
 Start switch 4-11
 Steering, checking 7-30
 Storage 8-4
 Supporting the motorcycle 7-34
 Swingarm pivots, lubricating 7-29
- T**
 Throttle grip and cable,
 checking and lubricating 7-27
 Throttle grip free play, adjusting 7-17
 Tires 7-18
 Tool kit 7-1
 Troubleshooting 7-38
 Troubleshooting charts 7-39
 Turn signal indicator light 4-2
 Turn signal light bulb, replacing 7-33
 Turn signal switch 4-11
- V**
 Valve clearance 7-17
 Vehicle identification number 10-1
 Vehicle lights 7-33
- W**
 Wheel bearings, checking 7-30

Index

Wheel (front).....	7-34
Wheel (rear).....	7-36
Wheels	7-19

Y

Yamalube.....	7-13
---------------	------

PRINTED IN INDIA



B1P-F8199-20



2Y183(OM-01)1281-07-18-E