



2022

OWNER'S MANUAL
MANUEL DU PROPRIÉTAIRE
BEDIENUNGSANLEITUNG
USO E MANUTENZIONE
MANUAL DEL PROPIETARIO

WR450F

 Read this manual carefully before operating this vehicle.

 Il convient de lire attentivement ce manuel avant la première utilisation du véhicule.





 Bitte lesen Sie diese Bedienungsanleitung sorgfältig durch, bevor Sie das Fahrzeug in Betrieb nehmen.

 Leggere attentamente questo manuale prima di utilizzare questo veicolo.

 Lea este manual atentamente antes de utilizar este vehículo.

WR450F
WR450FN

BDB-28199-51

-  **Read this manual carefully before operating this vehicle. This manual should stay with this vehicle if it is sold.**
-  **Il convient de lire attentivement ce manuel avant la première utilisation du véhicule. Le manuel doit être remis avec le véhicule en cas de vente de ce dernier.**
-  **Bitte lesen Sie diese Bedienungsanleitung sorgfältig durch, bevor Sie das Fahrzeug in Betrieb nehmen. Diese Bedienungsanleitung muss, wenn das Fahrzeug verkauft wird, beim Fahrzeug verbleiben.**
-  **Leggere attentamente questo manuale prima di utilizzare questo veicolo. Questo manuale dovrebbe accompagnare il veicolo se viene venduto.**
-  **Lea este manual atentamente antes de utilizar este vehículo. Este manual debe acompañar al vehículo si este se vende.**



2022

OWNER'S MANUAL

WR450F

⚠ Read this manual carefully before operating this vehicle.

WR450F
WR450FN

BDB-28199-51-E0

 **Read this manual carefully before operating this vehicle. This manual should stay with this vehicle if it is sold.**

CAN

Reporting safety defects (For Canada)

If you believe that your vehicle has a defect which could cause a crash or could cause injury or death, you should immediately inform Transport Canada in addition to notifying Yamaha Motor Canada Ltd, Canada. If Transport Canada receives similar complaints, it may open an investigation, and if it finds that a safety defect exists in a group of vehicles, it may order a recall and remedy campaign. However, Transport Canada cannot become involved in individual problems between you, your dealer, or Yamaha Motor Canada Ltd., Canada.

To contact Transport Canada, you may call Defect Investigations and Recall Division at 819-994-3328 or toll free 1-800-333-0510, go to www.tc.gc.ca or email: mvs-sa@tc.gc.ca or write to Transport Canada, 330 Sparks Street Ottawa, ON, K1A 0N5.

You can also obtain other information about motor vehicle safety from www.tc.gc.ca.

EUR

Declaration of Conformity:

Hereby, YAMAHA MOTOR CO., LTD declares that the radio equipment type, Communication Control Unit, T722-A00 is in compliance with Directive 2014/53/EU.

The full text of the EU declaration of conformity is available at the following internet address:

https://global.yamaha-motor.com/eu_doc/

Frequency band: 2.4GHz

The maximum radio frequency power: 50.12mW

Manufacturer:

YAMAHA MOTOR CO., LTD

2500 Shingai, Iwata, Shizuoka, 438-8501 Japan

Importer:

YAMAHA MOTOR EUROPE N.V.

Koolhovenlaan 101, 1119 NC Schiphol-Rijk, 1117 ZN, Schiphol, the Netherlands



Declaration of Conformity

In accordance with UK Government guidance

We, YAMAHA MOTOR CO., LTD. 2500 Shingai, Iwata, Japan,
declare in sole responsibility, that the product

Kind of Products: Off-Road Motorcycles

Model Year: 2022

Type Designation: WR450F
(Make, model)

The object of the declaration described above is in conformity with the
relevant UK Statutory Instruments (and their amendments):

2016 No. 1091 The Electromagnetic Compatibility Regulations 2016

Manufacturer

YAMAHA MOTOR CO., LTD.
2500 SHINGAI IWATA SHIZUOKA, JAPAN

Authorized Representative

YAMAHA MOTOR EUROPE N.V.
Koolhovenlaan 101. 1119 NC Schiphol-Rijk. The Netherlands

YAMAHA MOTOR EUROPE N.V., BRANCH UK
Units A2 & A3, Kingswey Business Park, Forsyth Road. Woking, Surrey, GU21 5SA, UK

Signature Shin Yokomizo
Senior General Manager. Shin Yokomizo
PF Model Development Section, PF Model Unit
YAMAHA MOTOR CO., LTD.
Date of Issue 17th, May, 2021

**WR450F
WR450FN
OWNER'S MANUAL
©2022 by Yamaha Motor Co., Ltd.
First edition, July 2021
All rights reserved.
Any reprinting or unauthorized use
without the written permission of
Yamaha Motor Co., Ltd.
is expressly prohibited.
Printed in Japan.**

IMPORTANT

Congratulations on your purchase of a Yamaha WR series. This model is the culmination of Yamaha's vast experience in the production of pacesetting racing machines. It represents the highest grade of craftsmanship and reliability that have made Yamaha a leader.

This manual explains operation, inspection, basic maintenance and tuning of your machine. If you have any questions about this manual or your machine, please contact your Yamaha dealer.

The design and manufacture of this Yamaha machine fully comply with the emissions standards for clean air applicable at the date of manufacture. Yamaha has met these standards without reducing the performance or economy of operation of the machine. To maintain these high standards, it is important that you and your Yamaha dealer pay close attention to the recommended maintenance schedules and operating instructions contained within this manual.

TIP

- Yamaha continually seeks advancements in product design and quality. Therefore, while this manual contains the most current product information available at the time of printing, there may be minor discrepancies between your machine and this manual. If you have any questions concerning this manual, please consult your Yamaha dealer.
- This manual is intended for those who have basic knowledge and skill concerning the servicing of Yamaha motorcycles (e.g., Yamaha dealers, service engineers, etc.). Those who have little knowledge and skill concerning servicing are requested not to undertake inspection, adjustment, disassembly, or reassembly only by reference to this manual. It may lead to servicing trouble and mechanical damage.



WARNING

PLEASE READ THIS MANUAL CAREFULLY AND COMPLETELY BEFORE OPERATING THIS MACHINE. DO NOT ATTEMPT TO OPERATE THIS MACHINE UNTIL YOU HAVE ATTAINED A SATISFACTORY KNOWLEDGE OF ITS CONTROLS AND OPERATING FEATURES AND UNTIL YOU HAVE BEEN TRAINED IN SAFE AND PROPER RIDING TECHNIQUES. REGULAR INSPECTIONS AND CAREFUL MAINTENANCE, ALONG WITH GOOD RIDING SKILLS, WILL ENSURE THAT YOU SAFELY ENJOY THE CAPABILITIES AND THE RELIABILITY OF THIS MACHINE.

IMPORTANT MANUAL INFORMATION

Particularly important information is distinguished in this manual by the following notations.

| | |
|-----------------------|--|
| | <p>This is the safety alert symbol. It is used to alert you to potential personal injury hazards. Obey all safety messages that follow this symbol to avoid possible injury or death.</p> |
| <p>WARNING</p> | <p>A WARNING indicates a hazardous situation which, if not avoided, could result in death or serious injury.</p> |
| <p>NOTICE</p> | <p>A NOTICE indicates special precautions that must be taken to avoid damage to the vehicle or other property.</p> |
| <p>TIP</p> | <p>A TIP provides key information to make procedures easier or clearer.</p> |

TABLE OF CONTENTS

| | |
|--|----------|
| GENERAL INFORMATION | 1 |
| SPECIFICATIONS | 2 |
| PERIODIC CHECKS AND ADJUSTMENTS | 3 |
| CHASSIS | 4 |
| ENGINE | 5 |
| FUEL SYSTEM | 6 |
| ELECTRICAL SYSTEM | 7 |
| TROUBLESHOOTING | 8 |
| TUNING | 9 |

GENERAL INFORMATION

| | |
|---|------|
| SAFETY INFORMATION | 1-1 |
| FOR SAFETY, BE SURE TO OBEY THE FOLLOWING: | 1-1 |
| LOCATION OF IMPORTANT LABELS | 1-4 |
| DESCRIPTION | 1-7 |
| IDENTIFICATION | 1-8 |
| VEHICLE IDENTIFICATION NUMBER | 1-8 |
| ENGINE SERIAL NUMBER | 1-8 |
| VEHICLE EMISSION CONTROL INFORMATION LABEL..... | 1-8 |
| INCLUDED PARTS | 1-9 |
| NIPPLE WRENCH..... | 1-9 |
| HANDLEBAR PROTECTOR..... | 1-9 |
| FUEL HOSE JOINT COVER..... | 1-9 |
| POWER TUNER (Except for Canada) | 1-9 |
| COUPLER FOR CONNECTING OPTIONAL PART (For Canada) | 1-10 |
| IMPORTANT INFORMATION | 1-11 |
| PREPARATION FOR REMOVAL AND DISASSEMBLY..... | 1-11 |
| REPLACEMENT PARTS..... | 1-11 |
| INSTRUMENT AND CONTROL FUNCTIONS | 1-12 |
| WARNING LIGHTS | 1-12 |
| ENGINE STOP SWITCH..... | 1-12 |
| START SWITCH..... | 1-12 |
| MODE SWITCH (Except for Canada) | 1-12 |
| SHIFT PEDAL | 1-13 |
| FRONT BRAKE LEVER | 1-13 |
| REAR BRAKE PEDAL..... | 1-13 |
| SIDESTAND | 1-13 |
| STARTER KNOB..... | 1-14 |
| FUEL TANK CAP | 1-14 |
| MULTI-FUNCTION DISPLAY | 1-15 |
| DESCRIPTION | 1-15 |
| SETTING THE TIMER..... | 1-15 |
| SETTING MODE | 1-17 |
| FUNCTION DIAGRAM | 1-20 |
| STARTING AND BREAK-IN | 1-22 |
| FUEL | 1-22 |
| HANDLING NOTE | 1-22 |
| STARTING A COLD ENGINE | 1-22 |
| STARTING A WARM ENGINE..... | 1-23 |

| | |
|--|-------------|
| BREAK-IN PROCEDURES | 1-23 |
| SHIFTING | 1-23 |
| MAINTENANCE AFTER BREAK-IN | 1-25 |
| MAJOR MAINTENANCE | 1-25 |
| AIR FILTER MAINTENANCE | 1-25 |
| TORQUE-CHECK POINTS..... | 1-26 |
| MOTORCYCLE CARE AND STORAGE | 1-28 |
| CARE..... | 1-28 |
| STORAGE | 1-29 |

EAM20168

SAFETY INFORMATION

Be sure to read this manual carefully and completely in order to operate the machine safely and correctly prior to riding the Yamaha machine, and take care to maintain it properly and operate it safely.

EAM30401

FOR SAFETY, BE SURE TO OBEY THE FOLLOWING:

Be a Responsible Owner

As the vehicle's owner, you are responsible for the safe and proper operation of your motorcycle.

Motorcycles are single-track vehicles.

Their safe use and operation are dependent upon the use of proper riding techniques as well as the expertise of the operator. Every operator should know the following requirements before riding this motorcycle.

He or she should:

1. Obtain thorough instructions from a competent source on all aspects of motorcycle operation.
2. Observe the warnings and maintenance requirements in this manual.
3. Obtain qualified training in safe and proper riding techniques.
4. Obtain professional technical service as indicated in this manual and/or when made necessary by mechanical conditions.
5. Never operate a motorcycle without proper training or instruction. Take a training course. Beginners should receive training from a certified instructor. Contact an authorized motorcycle dealer to find out about the training courses nearest you.

Safe Riding

Perform the pre-operation checks each time you use the vehicle to make sure it is in safe operating condition. Failure to inspect or maintain the vehicle properly increases the possibility of an accident or equipment damage. Refer to "PRE-OPERATION INSPECTION AND MAINTENANCE" on page 3-6 for a list of pre-operation checks.

1. This motorcycle is designed for off-road use only, therefore, it is illegal to operate it on public streets, roads, or highways, even a dirt or gravel one. Off-road use on public lands may be illegal. Please check local regulations before riding.
2. This motorcycle is designed to carry the oper-

ator only. No passengers.

3. The failure of motorists to detect and recognize motorcycles in traffic is the predominant cause of automobile/motorcycle accidents. Many accidents have been caused by an automobile driver who did not see the motorcycle. Making yourself conspicuous appears to be very effective in reducing the chance of this type of accident.

Therefore:

- Wear a brightly colored jacket.
 - Use extra caution when you are approaching and passing through intersections, since intersections are the most likely places for motorcycle accidents to occur.
 - Ride where other motorists can see you. Avoid riding in another motorist's blind spot.
 - Never maintain a motorcycle without proper knowledge. Contact an authorized motorcycle dealer to inform you on basic motorcycle maintenance. Certain maintenance can only be carried out by certified staff.
4. Many accidents involve inexperienced operators.
 - Make sure that you are qualified and that you only lend your motorcycle to other qualified operators.
 - Know your skills and limits. Staying within your limits may help you to avoid an accident.
 - We recommend that you practice riding your motorcycle until you have become thoroughly familiar with the motorcycle and all of its controls.
 5. Many accidents have been caused by error of the motorcycle operator. A typical error made by the operator is veering wide on a turn due to excessive speed or under cornering (insufficient lean angle for the speed). Never travel faster than warranted by conditions.
 6. Ride cautiously in unfamiliar areas. You may encounter hidden obstacles that could cause an accident.
 7. The posture of the operator is important for proper control. The operator should keep both hands on the handlebar and both feet on the operator footrests during operation to maintain control of the motorcycle.
 8. Never ride under the influence of alcohol or other drugs.
 9. Be sure the transmission is in neutral before starting the engine.

Protective Apparel

The majority of fatalities from motorcycle acci-

dents are the result of head injuries. The use of a safety helmet is the single most critical factor in the prevention or reduction of head injuries.

1. Always wear an approved helmet.
2. Wear a face shield or goggles. Wind in your unprotected eyes could contribute to an impairment of vision that could delay seeing a hazard.
3. The use of a jacket, heavy boots, trousers, gloves, etc., is effective in preventing or reducing abrasions or lacerations.
4. Never wear loose-fitting clothes, otherwise they could catch on the control levers, foot-rests, or wheels and cause injury or an accident.
5. Always wear protective clothing that covers your legs, ankles, and feet. The engine or exhaust system become very hot during or after operation and can cause burns.

Avoid Carbon Monoxide Poisoning

All engine exhaust contains carbon monoxide, a deadly gas. Breathing carbon monoxide can cause headaches, dizziness, drowsiness, nausea, confusion, and eventually death.

Carbon Monoxide is a colorless, odorless, tasteless gas which may be present even if you do not see or smell any engine exhaust. Deadly levels of carbon monoxide can collect rapidly and you can quickly be overcome and unable to save yourself. Also, deadly levels of carbon monoxide can linger for hours or days in enclosed or poorly ventilated areas. If you experience any symptoms of carbon monoxide poisoning, leave the area immediately, get fresh air, and **SEEK MEDICAL TREATMENT**.

1. Do not run engine indoors. Even if you try to ventilate engine exhaust with fans or open windows and doors, carbon monoxide can rapidly reach dangerous levels.
2. Do not run engine in poorly ventilated or partially enclosed areas such as barns, garages, or carports.
3. Do not run engine outdoors where engine exhaust can be drawn into a building through openings such as windows and doors.

Genuine Yamaha Accessories

Choosing accessories for your vehicle is an important decision. Genuine Yamaha accessories, which are available only from a Yamaha dealer, have been designed, tested, and approved by Yamaha for use on your vehicle.

Many companies with no connection to Yamaha manufacture parts and accessories or offer oth-

er modifications for Yamaha vehicles. Yamaha is not in a position to test the products that these aftermarket companies produce. Therefore, Yamaha can neither endorse nor recommend the use of accessories not sold by Yamaha or modifications not specifically recommended by Yamaha, even if sold and installed by a Yamaha dealer.

Aftermarket Parts, Accessories, and Modifications

While you may find aftermarket products similar in design and quality to genuine Yamaha accessories, recognize that some aftermarket accessories or modifications are not suitable because of potential safety hazards to you or others. Installing aftermarket products or having other modifications performed to your vehicle that change any of the vehicle's design or operation characteristics can put you and others at greater risk of serious injury or death. You are responsible for injuries related to changes in the vehicle. Keep the following guidelines in mind, as well as those provided under "Loading" when mounting accessories.

1. Never install accessories that would impair the performance of your motorcycle. Carefully inspect the accessory before using it to make sure that it does not in any way reduce ground clearance or cornering clearance, limit suspension travel, steering travel or control operation.
 - Accessories fitted to the handlebar or the front fork area can create instability due to improper weight distribution. If accessories are added to the handlebar or front fork area, they must be as lightweight as possible and should be kept to a minimum.
 - Bulky or large accessories may seriously affect the stability of the motorcycle. Wind may attempt to lift the motorcycle, or the motorcycle may become unstable in cross winds.
 - Certain accessories can displace the operator from his or her normal riding position. This improper position limits the freedom of movement of the operator and may limit control ability, therefore, such accessories are not recommended.
2. Use caution when adding electrical accessories. If electrical accessories exceed the capacity of the motorcycle's electrical system, an electric failure could result, which could cause a dangerous loss of lights or engine power.

Aftermarket Tires and Rims

The tires and rims that came with your motorcycle were designed to match the performance capabilities and to provide the best combination of handling, braking, and comfort. Other tires, rims, sizes, and combinations may not be appropriate. Refer to "CHECKING THE TIRES" on page 3-28 for tire specifications and more information on replacing your tires.

Transporting the Motorcycle

Be sure to observe following instructions before transporting the motorcycle in another vehicle.

1. Remove all loose items from the motorcycle.
2. Check that the fuel cock (if equipped) is in the "OFF" position and that there are no fuel leaks.
3. Point the front wheel straight ahead on the trailer or in the truck bed, and choke it in a rail to prevent movement.
4. Shift the transmission in gear (for models with a manual transmission).
5. Secure the motorcycle with tie-downs or suitable straps that are attached to solid parts of the motorcycle, such as the frame or upper front fork triple clamp (and not, for example, to rubber-mounted handlebars or turn signals, or parts that could break). Choose the location for the straps carefully so the straps will not rub against painted surfaces during transport.
6. The suspension should be compressed somewhat by the tie-downs, if possible, so that the motorcycle will not bounce excessively during transport.

LOCATION OF IMPORTANT LABELS

EAM20085

LOCATION OF IMPORTANT LABELS

Please read the following important labels carefully before operating this vehicle.

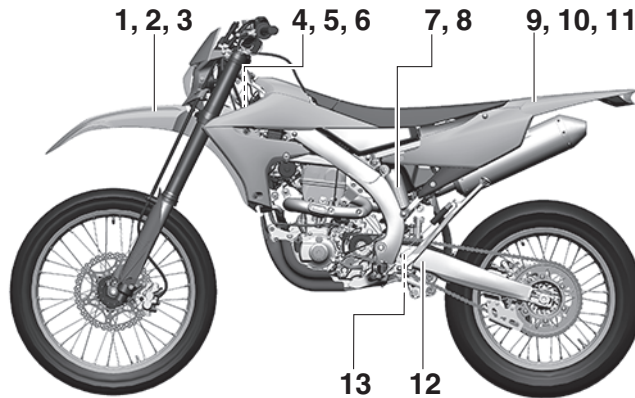

CAN

1

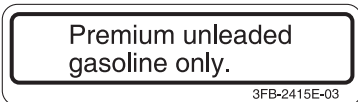

5

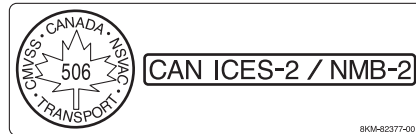

2

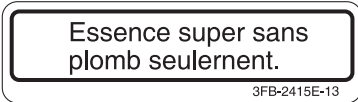

7

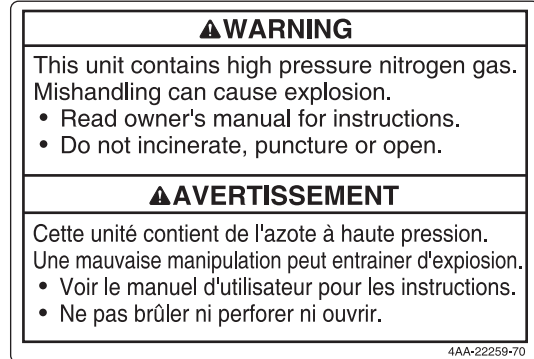

3

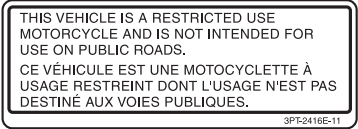

4

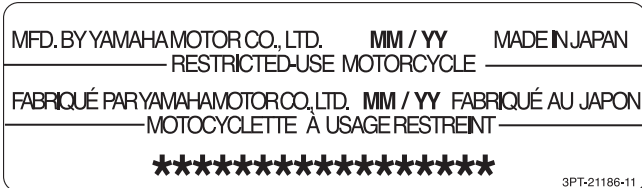

LOCATION OF IMPORTANT LABELS

9

⚠ WARNING

- BEFORE YOU OPERATE THIS VEHICLE, READ THE OWNER'S MANUAL AND ALL LABELS.
- NEVER CARRY A PASSENGER. You increase your risk of losing control if you carry a passenger.
- NEVER OPERATE THIS VEHICLE ON PUBLIC ROADS. You can collide with another vehicle if you operate this vehicle on a public road.
- ALWAYS WEAR AN APPROVED MOTORCYCLE HELMET, eye protection, and protective clothing.
- EXPERIENCED RIDER ONLY.

5PA-2118K-00

10

⚠ AVERTISSEMENT

- LIRE LE MANUEL DU PROPRIETAIRE AINSI QUE TOUTES LES ETIQUETTES AVANT D'UTILISER CE VEHICULE.
- NE JAMAIS TRANSPORTER DE PASSAGER. La conduite avec passager augmente les risques de perte de contrôle.
- NE JAMAIS ROULER SUR DES CHEMINS PUBLICS. Vous pourriez entrer en collision avec un autre véhicule.
- TOUJOURS PORTER UN CASQUE DE MOTOCYCLISTE APPROUVE, des lunettes et des vêtements de protection.
- EXCLUSIVEMENT POUR L'USAGE D'UN CONDUCTEUR EXPERIMENTE.

5PA-2118K-10

12

TIRE INFORMATION

Cold tire normal pressure should be set as follows:
FRONT : 100kPa, {1.00kgf/cm²}, 15psi
REAR : 100kPa, {1.00kgf/cm²}, 15psi

3RV-21668-A0

13

INFORMATION SUR LES PNEUS

La pression des pneus à froid doit normalement être réglée comme suit.
AVANT : 100kPa, {1.00kgf/cm²}, 15psi
ARRIERE : 100kPa, {1.00kgf/cm²}, 15psi

3RV-21668-B0

LOCATION OF IMPORTANT LABELS

AUS, NZL, ZAF

8



12

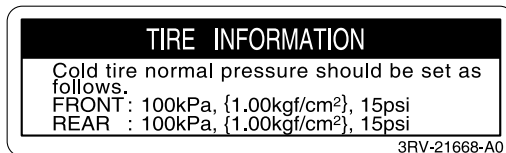

9

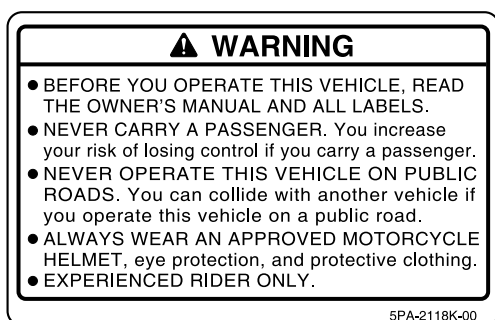

EUR

6

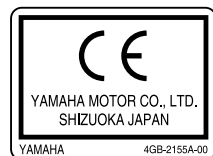

11

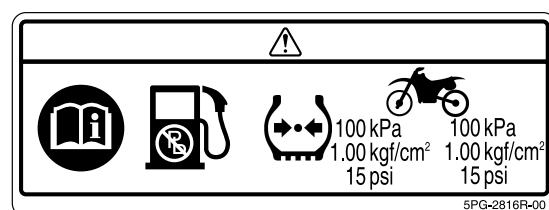



8

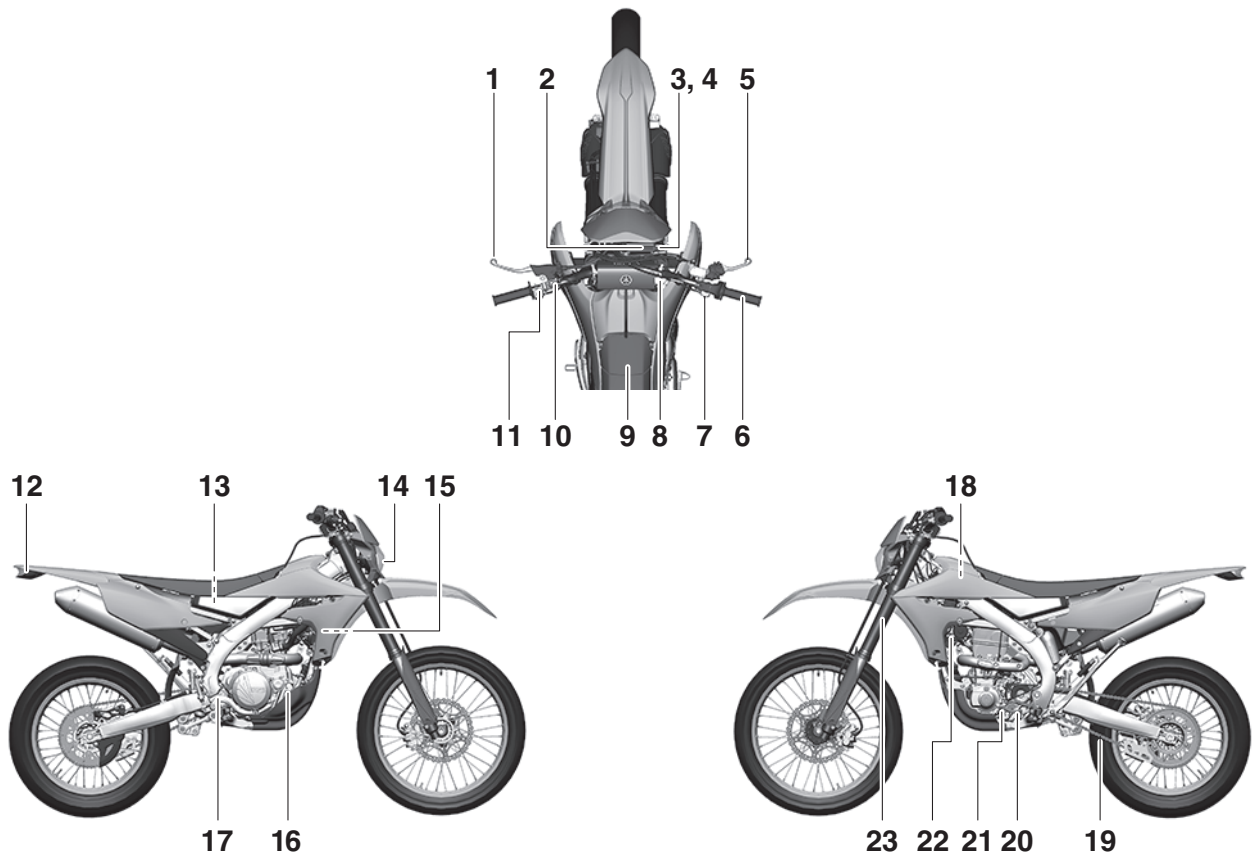

EAM20086

DESCRIPTION



1. Clutch lever
2. Multi-function display
3. Engine trouble warning light “”
4. Fuel level warning light “”
5. Front brake lever
6. Throttle grip
7. Start switch
8. Radiator cap
9. Fuel tank cap
10. Mode switch (Except for Canada)
11. Engine stop switch
12. Taillight

13. Fuel tank
14. Headlight
15. Radiator
16. Coolant drain bolt
17. Rear brake pedal
18. Air filter
19. Drive chain
20. Shift pedal
21. Oil level check window
22. Starter knob
23. Front fork

TIP

Designs and specifications of the vehicle are subject to change without notice. Therefore, please note that the descriptions in this manual may be different from those for the vehicle you have purchased.

EAM20087

IDENTIFICATION

There are two significant reasons for knowing the serial number of your vehicle:

1. When ordering parts, you can give the number to your Yamaha dealer for positive identification of the model you own.
2. If your vehicle is stolen, the authorities will need the number to search for and identify your vehicle.

EAM30002

VEHICLE IDENTIFICATION NUMBER

The vehicle identification number "1" is stamped into the right side of the frame.

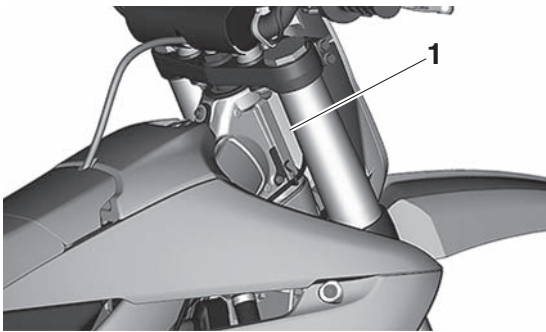

EAM30003

ENGINE SERIAL NUMBER

The engine serial number "1" is stamped into the elevated part of the right-side of the engine.

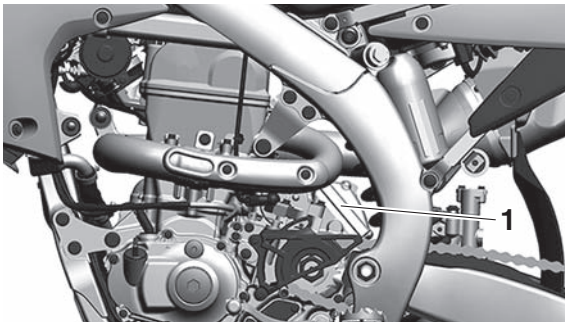

EAM30324

VEHICLE EMISSION CONTROL INFORMATION LABEL

The Vehicle Emission Control Information label "1" is affixed at the location in the illustration.

This label shows specifications related to exhaust emissions as required by federal law, state law and Environment Canada.

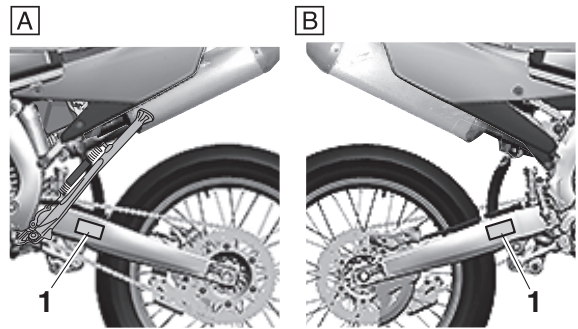

A. For Canada

B. For Canada

EAM20088

INCLUDED PARTS

EAM30005

NIPPLE WRENCH

The nipple wrench “1” is used to tighten the spoke.

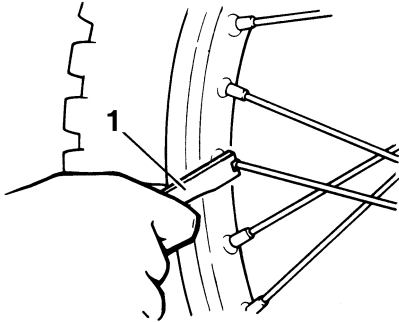

EAM30006

HANDLEBAR PROTECTOR

Install the handlebar protector “1” with the mark “a” facing forward.

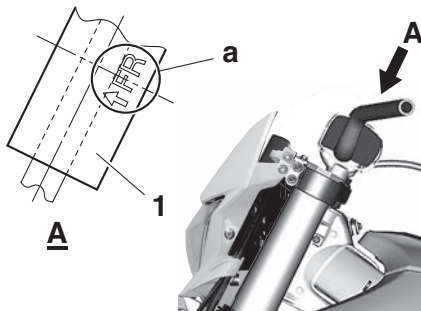

EAM30007

FUEL HOSE JOINT COVER

The fuel hose joint covers “1” are used to prevent mud, dust, and other foreign materials from entering the inside when the fuel hose is disconnected.

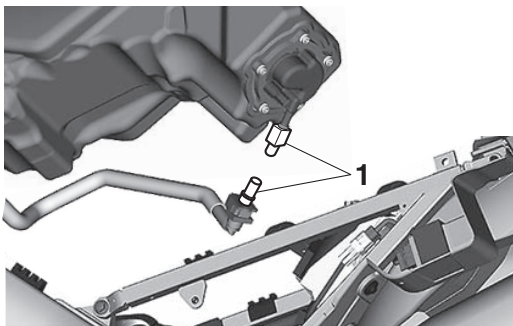

EAM30443

POWER TUNER (Except for Canada)

By downloading the Power Tuner app to your smartphone and wirelessly connecting to the CCU wireless network, you can adjust various vehicle settings.

EWA20460

WARNING

- Do not operate the engine in a closed area. The exhaust gas is poisonous.
- Never let flames near the servicing area.

ECA26050

NOTICE

- This application is designed for adjusting the settings on a standard vehicle. In case the engine specifications (muffler, compression ratio, etc.) have been changed, the performance may not match to the actual settings.
- Do not run the engine with the smartphone carried with you. Otherwise, the smartphone could be damaged.

TIP

- Download the Power Tuner app from the Google© or Apple© store.
- For details about handling the smartphone, read the owner’s manual of the smartphone.

Before connecting to the CCU wireless network (in case of initial use of the Power Tuner app)

1. Remove the bolts and side cover (left).

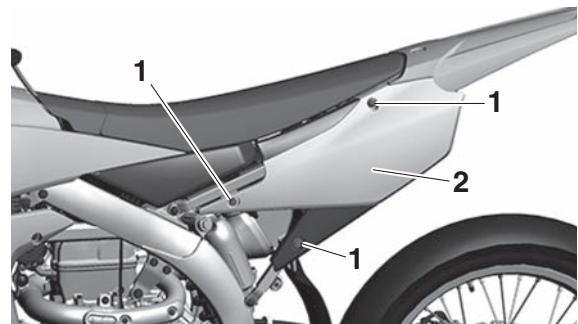

1. Bolt
2. Side cover (left)

2. Remove the CCU and record the CCU serial number.

INCLUDED PARTS

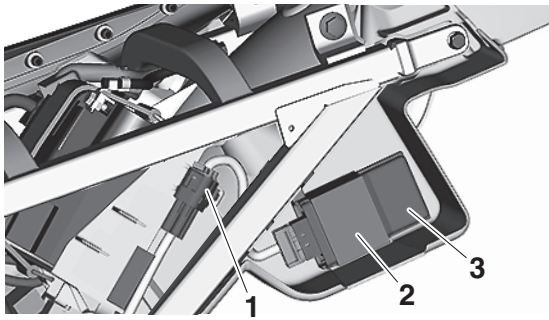

1. CCU coupler
2. Holder
3. CCU (Communication Control Unit)

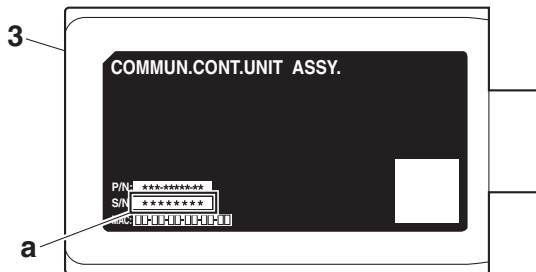

3. CCU (Communication Control Unit)
- a. CCU serial number

3. Install the removed CCU and side cover (left).
Connecting to the CCU wireless network

ECA26060

NOTICE

The CCU (Communication Control Unit) uses weak radio waves. The CCU may not work in the following situations.

- The CCU is placed in a location exposed to strong radio waves or other electromagnetic noise
- There are facilities nearby that are emitting strong radio waves (TV or radio towers, power plants, broadcasting stations, airports, etc.)
- You are carrying or using communication equipment such as radios or mobile phones in close proximity of the CCU
- The CCU is in contact with or covered by a metallic object
- Other vehicles equipped with a CCU are nearby

In such situations, move the CCU to another location and perform the operation again.

1. Turn on the smartphone.
2. For two minutes after the start switch is

pressed or while the engine is running (the CCU is activated), input the CCU serial number into your smartphone and establish a wireless connection.

3. Activate the Power Tuner app.

TIP

If the CCU wireless network cannot be detected, operate the start switch again.

EAM30008

COUPLER FOR CONNECTING OPTIONAL PART (For Canada)

The coupler "1" is used for connecting the optional Power Tuner and so on.

ECA24810

NOTICE

When no optional parts, etc. are connected, connect the connection terminal to the original coupler.

Before disconnecting the coupler, thoroughly wipe off any mud or water stuck to it.

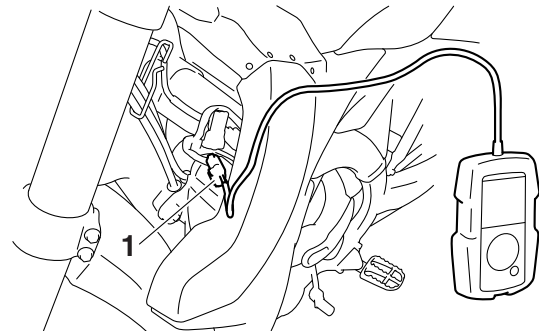

| Part name | Part number |
|------------------|-----------------|
| GYTR POWER TUNER | 33D-859C0-11-00 |

The Power Tuner is an optional part.

EAM20089

IMPORTANT INFORMATION

EAM30009

PREPARATION FOR REMOVAL AND DISASSEMBLY

1. Before the jobs, completely remove mud, dust, and the like in order to prevent the entry of them into the inside during the jobs. Refer to "CARE" on page 1-28.

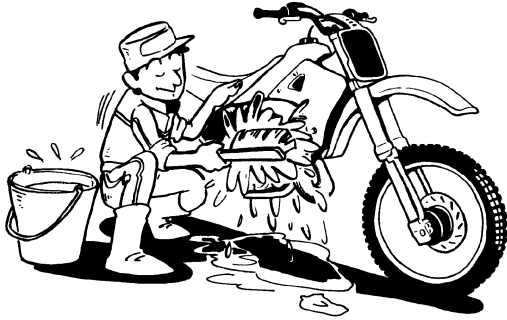

2. During disassembly, check and measure the required parts, and make a record of them so that you may refer to the record when installing them. Moreover, arrange gears, cylinders, pistons, and other parts for each section so as not to confuse or lose them.



3. During disassembly, clean each of the parts, and store them in trays for each section.
4. Flammable. Keep servicing areas away from any source of fire.
5. During servicing, take special care not to receive an injury or a burn on the engine, the exhaust pipe, the silencer, or the like.
6. If coolant is left adhered to the chassis, paint and plating will be damaged. Therefore, rinse it out with water in good time.

EWA18970

WARNING

Coolant is potentially harmful and should be handled with special care.

- If it enters your eyes, wash it away with water enough and then get medical attention
- If it splashes on your skin or clothes, quickly wash it away with water and then with

soapy water.

- If it is swallowed, immediately induce vomiting and get medical attention.

EAM30010

REPLACEMENT PARTS

Make sure that the parts and grease or oil to be used for repair of the vehicle, including periodic replacement parts, are new YAMAHA genuine parts and recommended parts.

Do not use any used parts, because these may not be genuine though they have similar appearances or because the quality may be changed by aging.

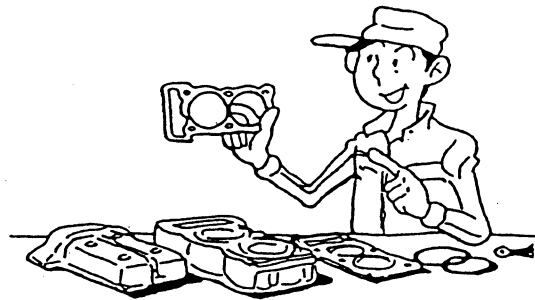

INSTRUMENT AND CONTROL FUNCTIONS

EAM20181

INSTRUMENT AND CONTROL FUNCTIONS

EAM30400

WARNING LIGHTS

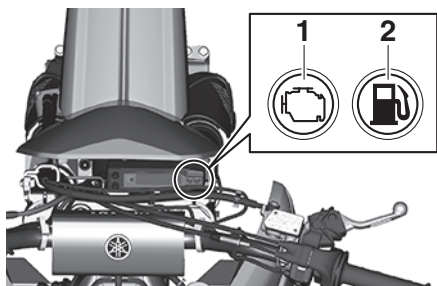

1. Engine trouble warning light “”
2. Fuel level warning light “”

Engine trouble warning light “”

This warning light comes on or flashes if a problem is detected in the electrical circuit monitoring the engine. If this occurs, have a Yamaha dealer check the vehicle.

The electrical circuit of the warning light can be checked by pushing the start switch. The warning light should come on for a few seconds, and then go off.

If the warning light does not come on initially when the start switch is pushed, or if the warning light remains on, have a Yamaha dealer check the electrical circuit.

Fuel level warning light “”

This warning light comes on when the fuel level drops below approximately 2.0 L (0.53 US gal, 0.44 Imp.gal). When this occurs, refuel as soon as possible.

The electrical circuit of the warning light can be checked by pushing the start switch. The warning light should come on for a few seconds, and then go off.

If the warning light does not come on initially when the start switch is pushed, or if the warning light remains on, have a Yamaha dealer check the electrical circuit.

EAM30182

ENGINE STOP SWITCH

The engine stop switch “1” is located on the left handlebar. Continue pushing the engine stop switch till the engine comes to a stop.

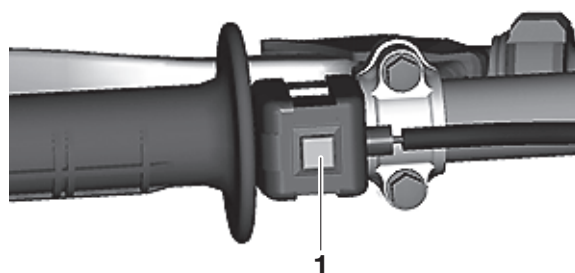

EAM30183

START SWITCH

The start switch “1” is located on the right handlebar. Push this switch to crank the engine with the starter.

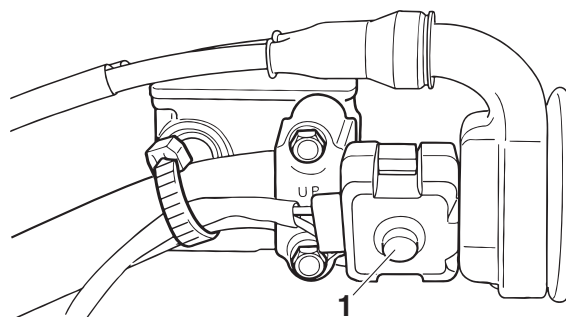

EAM30471

MODE SWITCH (Except for Canada)

The mode switch “1” is located on the left handlebar.

Press the mode switch to change between map 1 and map 2.

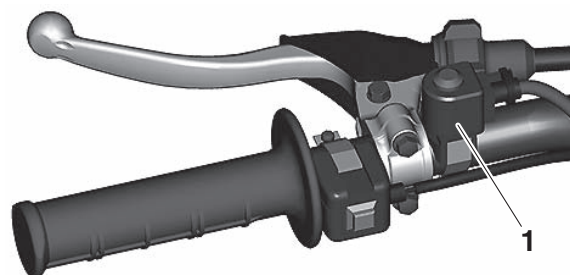

To change the mode

1. Shift to neutral.
2. Start the engine.
3. Press the mode switch.

Map 1

All-around good engine power and throttle response.

Map 2

Milder throttle response for riding technical sections.

INSTRUMENT AND CONTROL FUNCTIONS

TIP

You can use the Power Tuner app to adjust the map settings.

When the mode switch “1” is illuminated, map 2 is selected.

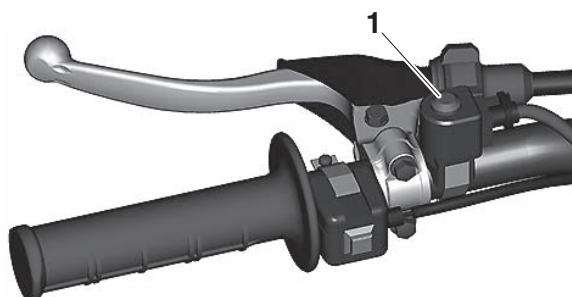

EAM30185

SHIFT PEDAL

The shift pedal “1” has adopted a method of 1 down & 4 ups (press-down & kick-ups).

Press it down for N (neutral) to 1st, and kick it up for 2nd to 5th.

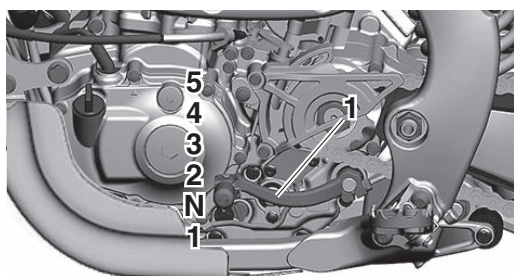

Recommended shift points

The recommended shift points during acceleration and deceleration are shown in the table below.



Shift up points

1st → 2nd

20 km/h (12 mph)

2nd → 3rd

30 km/h (19 mph)

3rd → 4th

40 km/h (25 mph)

4th → 5th

50 km/h (31 mph)

Shift down points

5th → 4th

35 km/h (22 mph)

4th → 3rd

25 km/h (16 mph)

3rd → 2nd

25 km/h (16 mph)

2nd → 1st

25 km/h (16 mph)

EAM30188

FRONT BRAKE LEVER

The front brake lever “1” is located on the right handlebar. Pull it toward the handlebar to activate the front brake.

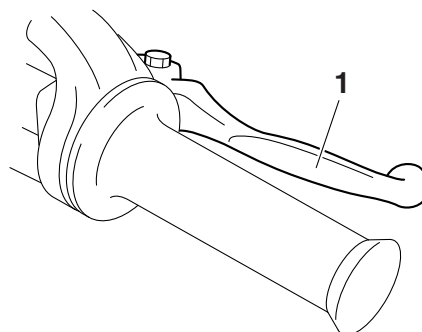

EAM30189

REAR BRAKE PEDAL

The rear brake pedal “1” is in the right of the chassis. Press down on the brake pedal to activate the rear brake.

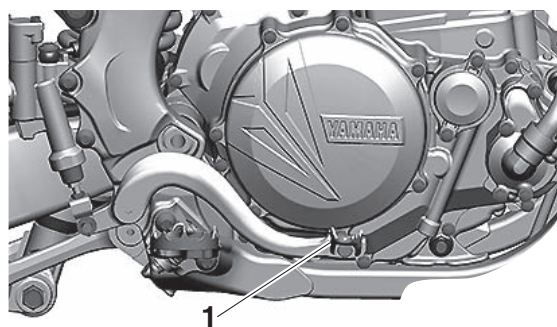

EAM30190

SIDESTAND

This sidestand “1” is used to support only the machine when standing.

INSTRUMENT AND CONTROL FUNCTIONS

EWA18980

⚠ WARNING

- Never apply additional force to the sidestand.
- Hold up the sidestand before starting out.

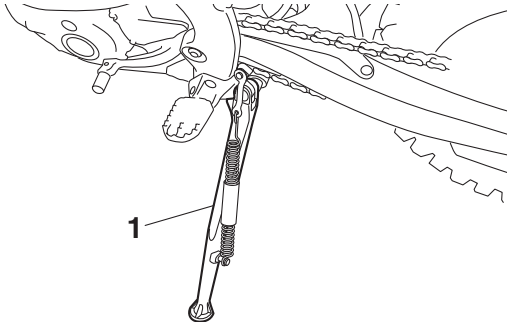

EAM30444

STARTER KNOB

Starting a cold engine requires a larger amount of intake air, which is supplied by the starter knob "1".

Pushing the knob toward "a" turns ON the starter, resulting in a larger angle of throttle valve.

TIP

When operating the throttle grip in the closing direction, the starter knob "1" moves in the direction "b" as shown and returns to its original position.

EWA20470

⚠ WARNING

While handling the starter knob, take care not to burn yourself on exhaust pipes.

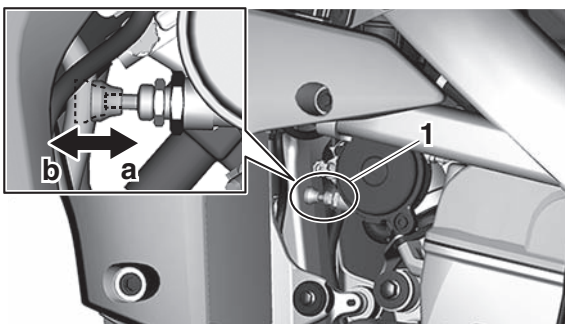

EAM30192

FUEL TANK CAP

Fuel tank cap "1" is located under the fuel tank cap cover "2".

Remove the fuel tank cap cover to open the fuel tank cap.

TIP

- To remove the fuel tank cap cover, insert fingers under part "a", and then use both hands to lift it up towards the rear of the vehicle.

- Install the fuel tank cap cover after placing the bands "3" all the way in under the seat.

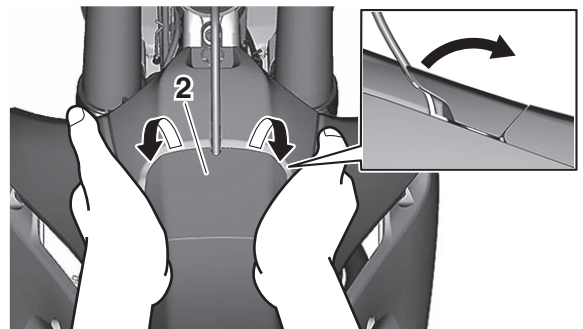
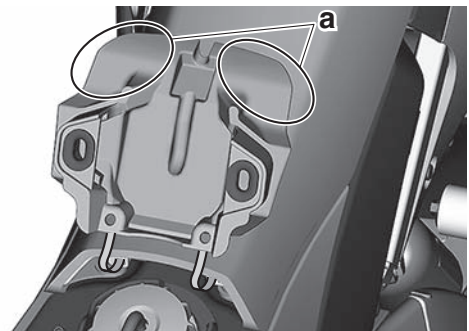
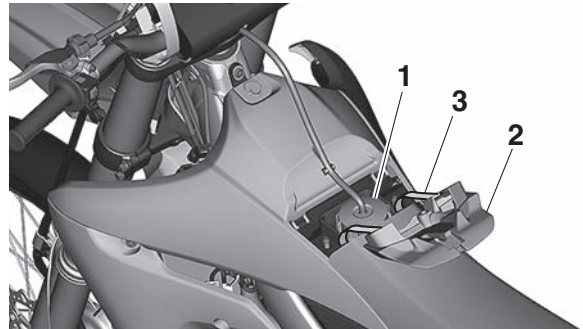

MULTI-FUNCTION DISPLAY

EAM20150

MULTI-FUNCTION DISPLAY

EWA19000

WARNING

Be sure to stop the machine before making any setting changes to the multi-function display.

The multi-function display is equipped with the following:

- Speedometer
- Clock
- Two tripmeters (which show the distance that has been traveled since it was last set to zero)
- Accumulated fuel consumption meter
- Timer (which shows the time that has been accumulated since the start of timer measurement)

EAM30326

DESCRIPTION

Operation buttons:

1. A button
2. B button

Screen display:

3. Tripmeter indicator "A"
4. Tripmeter indicator "B"
5. Timer indicator "T"
6. Odometer indicator "ODO"
7. Accumulated fuel consumption meter indicator "L", "GAL"
8. Odometer/Tripmeter/Clock/Timer/Accumulated fuel consumption meter
9. Speedometer

TIP

- The operation buttons can be pushed in the following two manners:
Short push: Push the button. (⇨)
Long push: Push the button for 1 second or more. (⇨)
- The display unit depends on the destination.
Except for U.K.
Speedometer: km/h
Accumulated fuel consumption meter indicator: L
For U.K.
Speedometer: MPH
Accumulated fuel consumption meter indicator: GAL

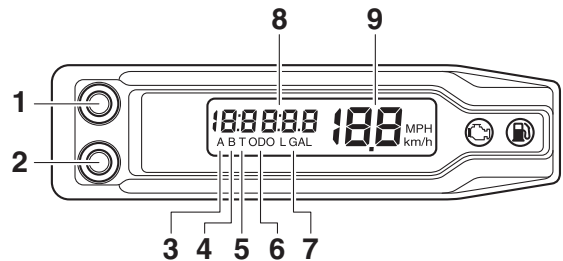

Changing the display item

TIP

- The odometer will lock at 199999.
- The tripmeter will reset and continue counting after 9999.9 is reached.
- The accumulated fuel consumption meter will lock at 19.9.

1. Push the A button to change the meter display.

The display will change in the following order:
ODO → TRIP A → TRIP B → Clock → Timer → Accumulated fuel consumption → ODO

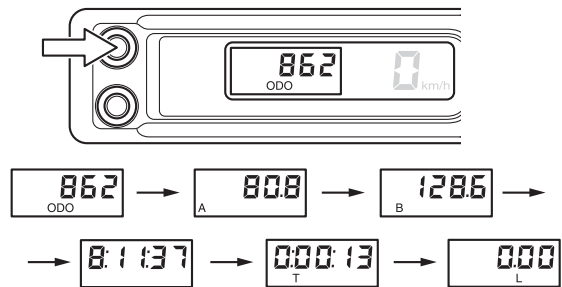

TIP

To reset the digits, select the meter involved and push the A button for 1 second or more.

EAM30621

SETTING THE TIMER

Putting measurement on standby

1. Change the meter display to the timer mode.

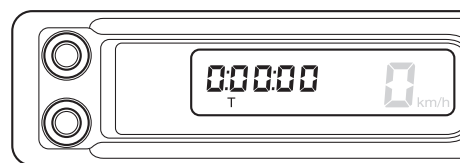

MULTI-FUNCTION DISPLAY

TIP

- Starting measurement consists of the following two starts, either of which can be selected.

Manual start:

Starting measurement by the rider himself operating the button.

Auto start:

Starting timer measurement automatically on detection of the movement of the machine.

(When long pushing the A button and B button simultaneously, the measurement will become waiting status.)

- When the timer exceeds 19:59:59, the measurement value will reset and stop.
- When the last traveled time remains in the timer display and you want to perform a new measurement, long push the A button for 1 second or more to reset the timer.

Manual start

1. Push the A button and B button simultaneously to start the timer measurement.
2. Push the A button and B button simultaneously to stop the timer measurement.

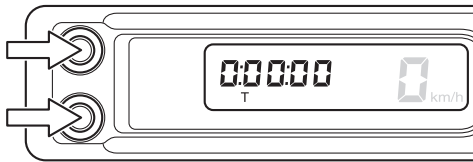

TIP

Long pushing the A button for 1 second and more while the timer measurement is being stopped will reset the value.

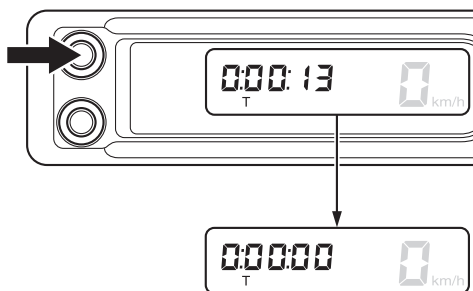

3. Push the A button and B button simultaneously once again to restart the measurement.

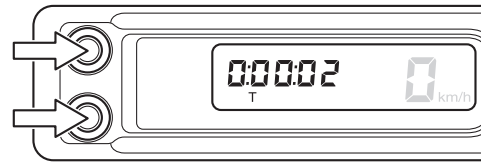

Auto start

1. When pushing the A button and B button simultaneously for 1 second or more while the timer measurement has been stopped, the auto timer measurement will be set.

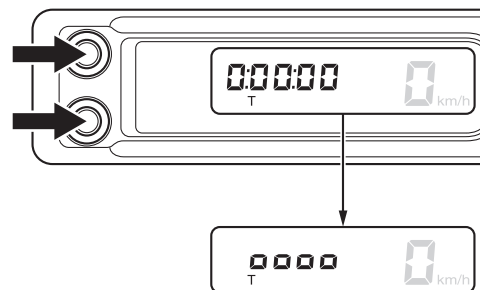

TIP

- When the measurement is ready to begin by auto starting, the timer display will turn on scrolling from left to right.
- When the speed exceeds 10 km/h (6 mph), the measurement will start.

2. Push the A button and B button simultaneously to stop the timer measurement.

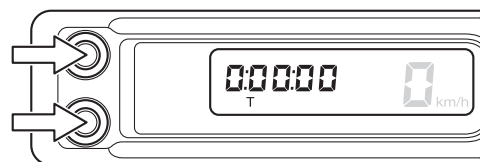

TIP

Long pushing the A button for 1 second and more while the timer measurement is being stopped will reset the value.

When reset is done, auto start will be canceled. If you want to set auto start again, perform step (1) of the settings.

MULTI-FUNCTION DISPLAY

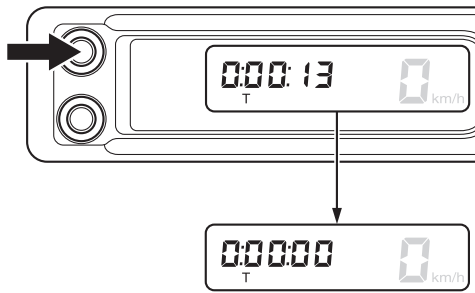

3. Push the A button and B button simultaneously once again to restart the measurement.



EAM30622

SETTING MODE

Shifting to the setting mode

1. Keep the A button pushed and activate the display.

After the display is activated, when the setting mode is shifted to the first backlight brightness setting, release the A button.

The display will change in the order:

Setting the backlight brightness → Setting the clock time (hour) → Setting the clock time (minute) → Setting the unit → Setting the fuel consumption correction → Setting the backlight brightness

TIP

If one of the following situations occurs while performing the setting mode, the setting value that is displayed will be accepted even if the settings are not finished, and the setting mode display will disappear.

- The display has been turned off
- The vehicle has been moved
- A communication error has occurred.

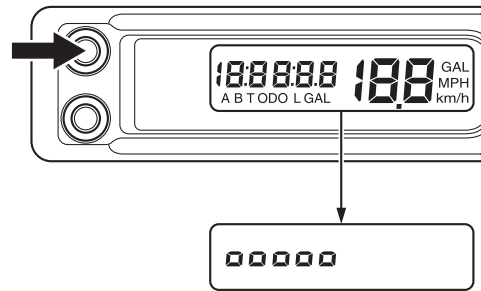

Setting the backlight brightness

1. Push the B button and adjust the brightness.
2. When the B button is pushed, the number of segments will increase one by one as the meter brightness increases.

If you push the B button when 5 segments (highest setting) are selected, the segments will go back to “— — — — —” and the brightness of the meter will become low.

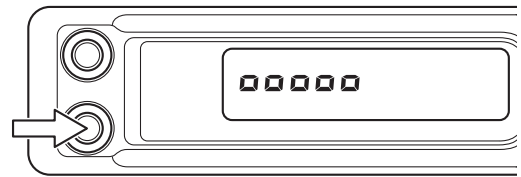

3. When the brightness has been adjusted as desired, push the A button.

The setting of the meter brightness will then be kept and the display of the multifunction meter will shift to the clock time setting.

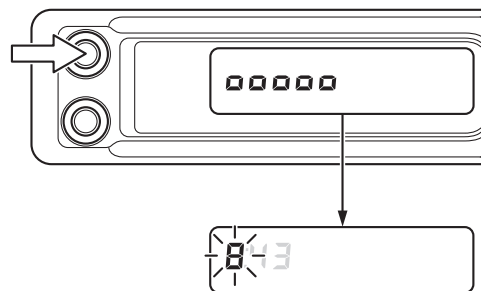

Setting the clock time

Setting the hour

1. Push the B button to adjust the hour.
A long push on the button will fast-forward the time.

TIP

The digits capable of setting go on flashing.

MULTI-FUNCTION DISPLAY

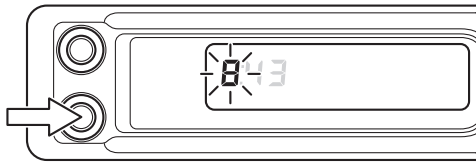

2. Push the A button to set the hour, and then shift to the minute setting.

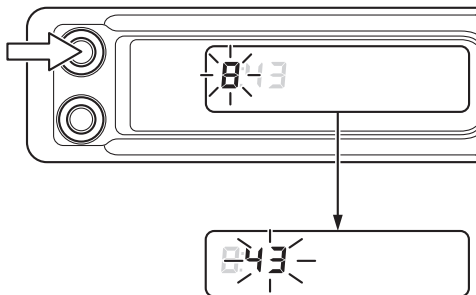

Setting the minute

1. Push the B button to adjust the minute.
A long push on the button will fast-forward the time.

TIP
The digits capable of setting go on flashing.

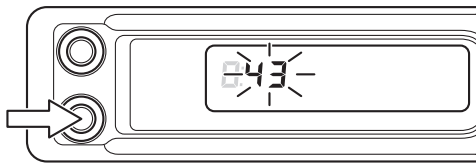

2. Push the A button to set the minute. The setting of the time will then be kept and the display of the multifunction meter will shift to the unit display setting.

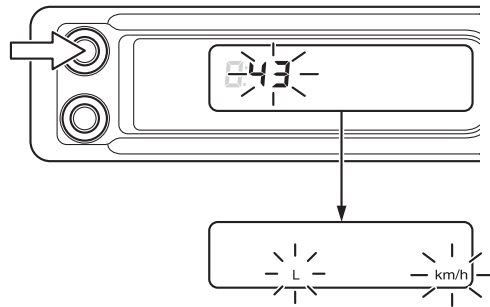

Setting the unit change

1. Push the B button to change the units of the speedometer and fuel.

The unit display will change in the following order:

Except for U.K.

Accumulated fuel consumption meter: L → GAL → L

Speedometer: km/h → MPH → km/h

For U.K.

Accumulated fuel consumption meter: GAL → L → GAL

Speedometer: MPH → km/h → MPH

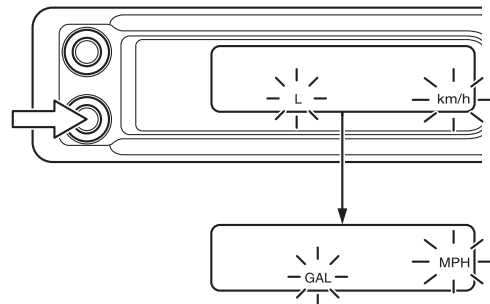

2. Push the A button to set the unit. The unit setting will then be kept and the display of the multifunction meter will shift to the fuel consumption correction setting.

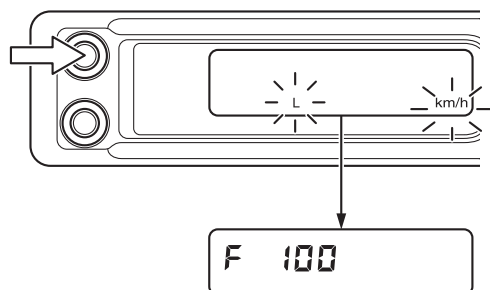

Setting the fuel consumption correction

The accumulated fuel consumption correction is a mode that adjusts the fuel consumption rate according to the riding style of the driver and ambient temperature.

MULTI-FUNCTION DISPLAY

1. Push the B button to adjust the setting.
A long push on the button will fast-forward the setting value.

TIP

- The initial setting value of the accumulated fuel consumption correction is set as 100 %.
 - Pushing the B button at a setting value of 110 % will return the setting to 90 %.
-

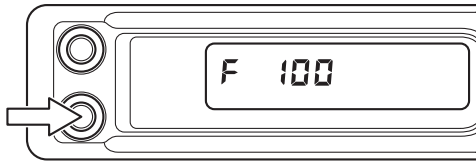

2. Push the A button to set the fuel consumption correction value.
The correction value will then be kept and the display of the multifunction meter will shift to the backlight brightness setting.

TIP

When terminating the setting mode, long push the engine stop switch to turn off the display and terminate the setting mode.

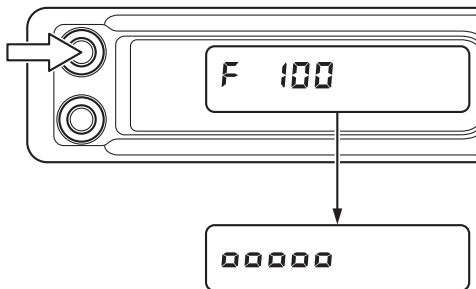

MULTI-FUNCTION DISPLAY

EAM30330

FUNCTION DIAGRAM

TIP

The following diagram illustrates the multi-function display regarding the direction and operation condition involved in each of its functions.

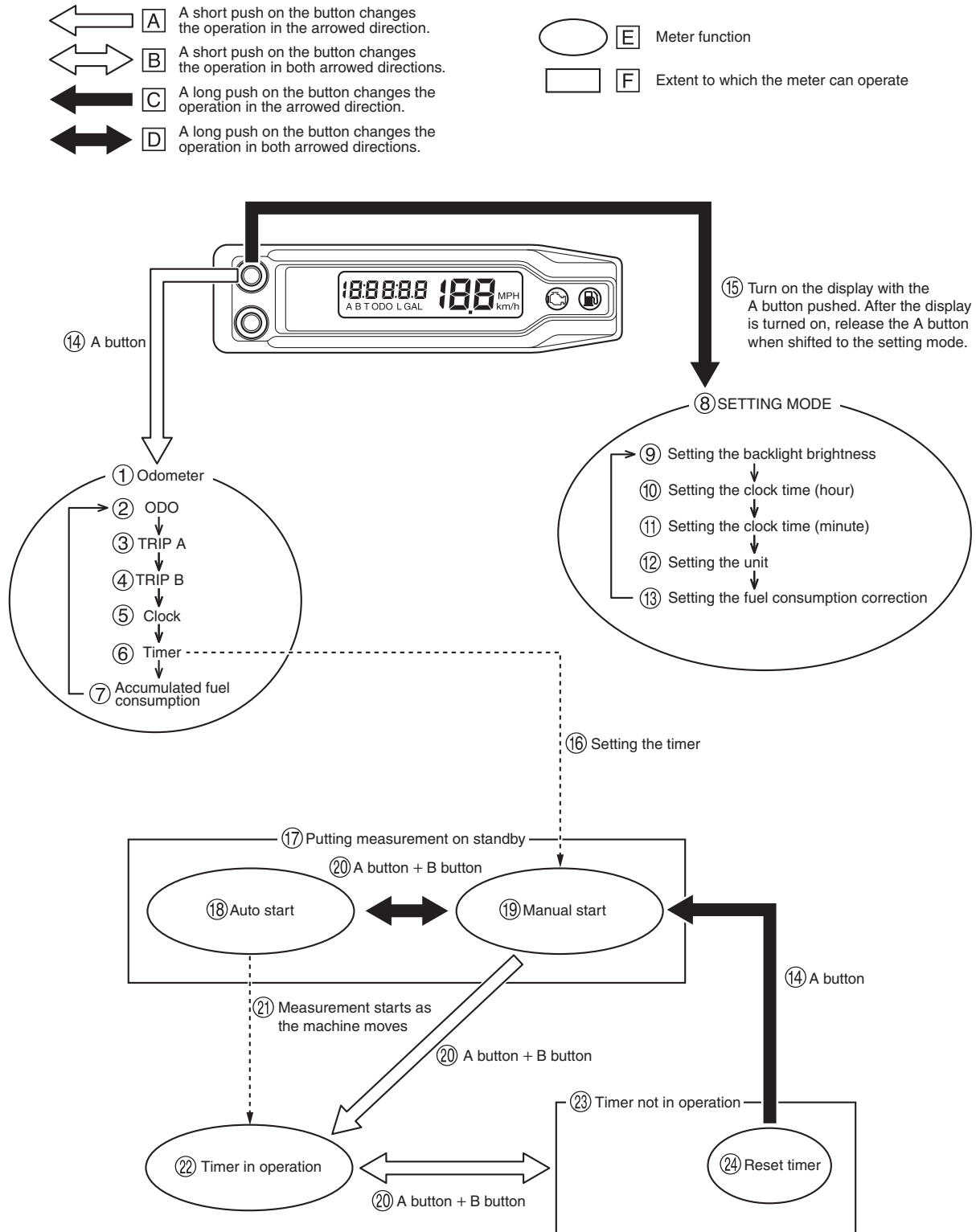

MULTI-FUNCTION DISPLAY

- A. A short push on the button changes the operation in the arrowed direction.
 - B. A short push on the button changes the operation in both arrowed directions.
 - C. A long push on the button changes the operation in the arrowed direction.
 - D. A long push on the button changes the operation in both arrowed directions.
 - E. Meter function
 - F. Extent to which the meter can operate
1. Odometer
 2. ODO
 3. TRIP A
 4. TRIP B
 5. Clock
 6. Timer
 7. Accumulated fuel consumption
 8. SETTING MODE
 9. Setting the backlight brightness
 10. Setting the clock time (hour)
 11. Setting the clock time (minute)
 12. Setting the unit
 13. Setting the fuel consumption correction
 14. A button
 15. Turn on the display with the A button pushed.
After the display is turned on, release the A button when shifted to the setting mode.
 16. Setting the timer
 17. Putting measurement on standby
 18. Auto start
 19. Manual start
 20. A button + B button
 21. Measurement starts as the machine moves
 22. Timer in operation
 23. Timer not in operation
 24. Reset timer

STARTING AND BREAK-IN

EAM20123

STARTING AND BREAK-IN

EAM30193

FUEL

Always use the recommended fuel as stated below. Also, be sure to use new gasoline the day of a race.



Recommended fuel
Unleaded gasoline (E10 acceptable)
Octane number (R+M)/2
91 or higher
Fuel tank capacity
7.9 L (2.1 US gal, 1.7 Imp.gal)
Fuel reserve amount
2.0 L (0.53 US gal, 0.44 Imp.gal)

ECA24180

NOTICE

Use only unleaded gasoline. The use of leaded gasoline will cause severe damage to the engine internal parts such as valves, piston rings, and exhaust system, etc.

TIP

Your Yamaha engine has been designed to use unleaded gasoline with a pump octane number [(R+M)/2] of 91 or higher, or a research octane number of 95 or higher. If knocking (or pinging) occurs, use a gasoline of a different brand.

EWA19010

WARNING

- For refueling, be sure to stop the engine and use enough care not to spill any fuel. Also be sure to avoid refueling close to a fire.
- Refuel after the engine, exhaust pipe, etc. have cooled off.

Gasohol (For Canada)

There are two types of gasohol: gasohol containing ethanol and that containing methanol. Gasohol containing ethanol can be used if the ethanol content does not exceed 10 %. Gasohol containing methanol is not recommended by Yamaha because it can cause damage to the fuel system or vehicle performance problems.

EAM30194

HANDLING NOTE

EWA19020

WARNING

Never start or run the engine in a closed area. The exhaust fumes are poisonous; they can cause loss of consciousness and death

in a very short time. Always operate the machine in a well-ventilated area.

ECA25910

NOTICE

- If the throttle is open the air/ fuel mixture may be too lean for the engine to start.
- Before starting the machine, perform the checks in the pre-operation check list.

EAM30196

STARTING A COLD ENGINE

1. Press the shift pedal to neutral.
2. Push the starter knob "1" completely.

TIP

- When the ambient temperature is 15 °C (59 °F) or below, use the starter knob.
- Do not operate the throttle grip when operating the starter knob.

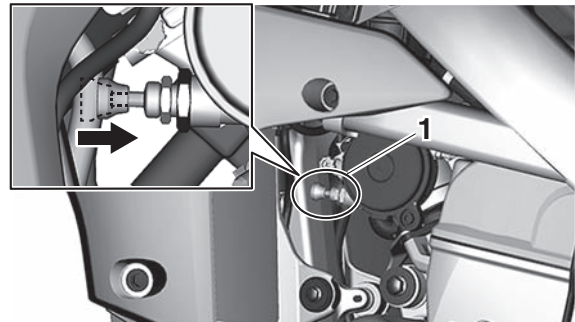

3. Start the engine by pushing the start switch. If the engine fails to start when using the start switch, release it, wait a few seconds, and then try again. Each starting attempt should be as short as possible to preserve the battery. Do not crank the engine more than 10 seconds on any one attempt.
4. When the engine starts running, warm this up one or two minutes at a steady speed (of 3000 to 5000 r/min), and then return the starter knob to its original position.

TIP

When operating the throttle grip in the closing direction, the starter knob "1" moves in the direction as shown and returns to its original position.

STARTING AND BREAK-IN

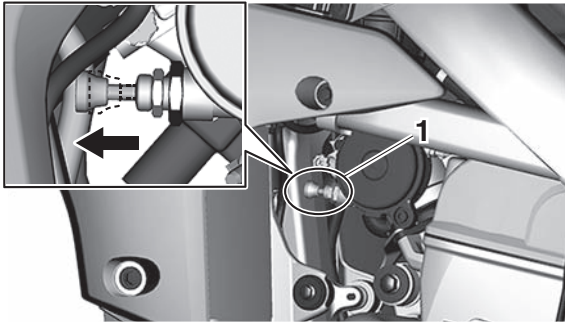

EWA19030

WARNING

Since exhaust gas contains harmful ingredients, do not start or warm it up at an ill-ventilated place or a closed narrow place.

5. To stop the engine, push the engine stop switch "1".

TIP

Continue pushing the engine stop switch till the engine comes to a full stop.

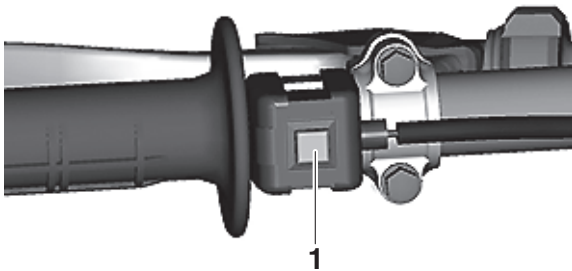

EAM30197

STARTING A WARM ENGINE

Follow the same procedure as for starting a cold engine with the exception that the starter is not required when the engine is warm.

TIP

If the engine fail to start, fully open the throttle grip and push the start switch few seconds to clear the engine of the rich air-fuel mixture retained in it.

EAM30198

BREAK-IN PROCEDURES

A break-in is important so that rotating portion, sliding surfaces, and mounted areas may fit one another, and that the rider may become accustomed to the machine.

ECA25811

NOTICE

Before running, do maintenance on the air filter element.

1. After warming up the engine, drive it for about 20 minutes at a throttle opening of 1/2 or less.

TIP

This model is equipped with an engine auto-stop system. The engine stops automatically if left idling for 7 minutes. If the engine stops, push the start switch to restart the engine.

2. Make a pit stop, and check mounted areas for looseness, oil leaks, or other problems.
3. Then, drive it for about 40 minutes at a throttle opening of 3/4 or less.
4. Make a pit stop again, and thoroughly check mounted areas for looseness, oil leaks, or other problems. Thorough checks and adjustments are required in particular for stretch of cables, free play of the brake, stretch of the drive chain, looseness of the spoke, and so on.

ECA25821

NOTICE

After a break-in or after each race, always check the points shown in "TORQUE-CHECK POINTS" for tightening torques and retighten them.

Also when the following parts are replaced, a break-in is required.

- Cylinder and Crankshaft: A break-in is required for about an hour.
- Piston, Piston ring, Valve, Camshaft, and Gear: A break-in is required for about 30 minutes at a throttle opening of 1/2 or less.

Observe the condition of the engine carefully during a break-in.

For checkpoints for a break-in, see "MAINTENANCE AFTER BREAK-IN". If any problem is found, immediately stop the engine and make a checkup.

EAM30623

SHIFTING

The shift pedal "1" has adopted a method of 1 down & 4 ups (press-down & kick-ups).

Press it down for N (neutral) to 1st, and kick it up for 2nd to 5th.

STARTING AND BREAK-IN

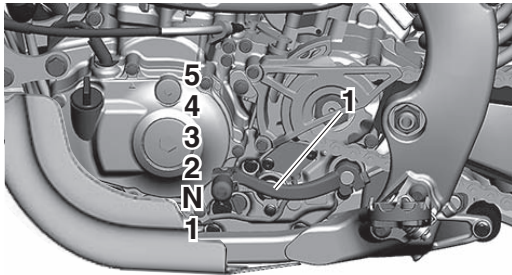

ECA10262

NOTICE

- When shifting, press the shift pedal firmly until you feel the gear shift is complete.
- Even with the transmission in the neutral position, do not coast for long periods of time with the engine off, nor tow the motorcycle for long distances. The transmission is properly lubricated only when the engine is running. Inadequate lubrication may damage the transmission.
- Always use the clutch while changing gears to avoid damaging the engine, transmission, and drive train, which are not designed to withstand the shock of forced shifting.

To start out and accelerate

1. Pull the clutch lever to disengage the clutch.
2. Shift the transmission into first gear.
3. Open the throttle gradually, and at the same time, release the clutch lever slowly.
4. At the recommended shift points shown in the following table, close the throttle, and at the same time, quickly pull the clutch lever in.
5. Shift the transmission into second gear. (Make sure not to shift the transmission into the neutral position.)
6. Open the throttle part way and gradually release the clutch lever.
7. Follow the same procedure when shifting to the next higher gear.

TIP

When shifting gears in normal operating conditions, use the recommended shift points.

To decelerate

1. Apply both the front and the rear brakes to slow the motorcycle.
2. Shift the transmission into first gear when the motorcycle reaches 20 km/h (12 mph). If the engine is about to stall or runs very roughly, pull the clutch lever in and use the brakes to stop the motorcycle.

3. Shift the transmission into the neutral position when the motorcycle is almost completely stopped.

Recommended shift points

The recommended shift points during acceleration and deceleration are shown in the table below.



Shift up points

1st → 2nd

20 km/h (12 mph)

2nd → 3rd

30 km/h (19 mph)

3rd → 4th

40 km/h (25 mph)

4th → 5th

50 km/h (31 mph)

Shift down points

5th → 4th

35 km/h (22 mph)

4th → 3rd

25 km/h (16 mph)

3rd → 2nd

25 km/h (16 mph)

2nd → 1st

25 km/h (16 mph)

EAM20124

MAINTENANCE AFTER BREAK-IN

After a break-in, perform careful maintenance to get ready for the next practice or race.

Refer to “PRE-OPERATION INSPECTION AND MAINTENANCE” on page 3-6.

EAM30199

MAJOR MAINTENANCE

1. For the engine

- Leaks around the engine
Check for pressure leaks from the cylinder head or the cylinder, oil leaks from the crankcase or the case cover, leaks from the coolant system, and other leaks.
- Check that the valve, the cylinder head, the cylinder, the piston, and the piston ring fit one another, and that contact between the valve and the cylinder head, and that between the cylinder and the piston are correct.
- Engine oil change
Drain the oil, and check for dirt and foreign materials such as metal chips. (If any foreign material is mixed, disassemble and check the crankcase.)
Pour the specified amount of the recommended oil.
- Generator
Check for looseness in mounted areas of the generator rotor and the stator coil assembly. Check that the connector is not being disconnected.
- Silencer
Check the main body and stay for cracks. Check for leaks.
- Mounting bolts and nuts
Check for looseness in mounted areas of parts, as well as engine mounting bolts and engine brackets.

2. For the chassis

- Check welds and mounted areas of the frame, the swingarm, the link, the bracket, and so on, for looseness and cracks.
- Wheel(s)
Check the wheel for runout. Check the spoke for looseness.
- Brake(s)
Check the brake disc mounting bolt for looseness.
Check that the reservoir contains the specified amount of brake fluid. Check for leaks.
- Cable
Grease and adjust cables.

- Drive chain
Lubricate the drive chain and adjust its tension.
- Fuel tank
Clean the inside of the fuel tank. Check for leaks.
- Suspension
Check for oil leaks in the front fork or the rear shock absorber. Check that the mounted conditions are good.
- Sprocket
Check for looseness in the sprocket mounted on the rear wheel.
- Mounting bolts and nuts
Check mounted areas for looseness.

ECA25831

NOTICE

After a break-in or before each race, always check the points shown in “TORQUE-CHECK POINTS” for tightening torques and retighten them.

- Greasing and oiling
Always grease or oil the specified points.

EAM30195

AIR FILTER MAINTENANCE

Apply the Yamaha foam air filter oil or other quality foam air filter oil to the element. (Excess oil in the element may adversely affect engine starting.) Refer to “CLEANING THE AIR FILTER ELEMENT” on page 3-12.

TORQUE-CHECK POINTS

EAM20125

TORQUE-CHECK POINTS

| | | | | | |
|---------------------------------|-------|---------------------------------|--|------------------------------------|------------------------------|
| Frame construction | | Combined seat and fuel tank | | Fuel tank to frame | |
| | | | | Frame to rear frame | |
| | | | | Frame to engine protector | |
| Engine mounting | | | | Frame to engine | |
| | | | | Engine bracket to engine | |
| | | | | Engine bracket to frame | |
| Seat | | | | Seat to frame | |
| Steering | | Steering stem to handlebar | | Steering stem to frame | |
| | | | | Steering stem to upper bracket | |
| | | | | Upper bracket to handlebar | |
| Suspension | Front | Steering stem to front fork | | Front fork to upper bracket | |
| | | | | Front fork to lower bracket | |
| | Rear | Link | | Assembly of links | |
| | | | | Link to frame | |
| | | | | Link to rear shock absorber | |
| | | | | Link to swingarm | |
| | | Mounting of rear shock absorber | | Rear shock absorber and frame | |
| Mounting of swingarm | | Tightening of pivot shaft | | | |
| Wheel(s) | | Mounting of wheel | | Front | Tightening of wheel axle |
| | | | | | Tightening of axle holder |
| | | | | | Tightening of spoke nipple |
| | | | | Rear | Tightening of wheel axle |
| | | | | | Wheel to rear wheel sprocket |
| | | | | | Tightening of spoke nipple |
| Brake(s) | | Front | | Brake caliper to front fork | |
| | | | | Brake disc to wheel | |
| | | | | Tightening of union bolt | |
| | | | | Brake master cylinder to handlebar | |
| | | | | Tightening of bleed screw | |
| | | | | Tightening of plate | |
| | | Rear | | Brake pedal to frame | |
| | | | | Brake disc to wheel | |
| | | | | Tightening of union bolt | |
| | | | | Brake master cylinder to frame | |
| | | | | Tightening of bleed screw | |
| Tightening of brake hose holder | | | | | |
| Fuel system | | | | Fuel pump to fuel tank | |

TORQUE-CHECK POINTS

| | |
|---------------|--|
| Shift pedal | Shift pedal to shift shaft |
| Plastic cover | Tightening of front fender |
| | Tightening of fork leg protector |
| | Tightening of air scoop |
| | Left cover to rear frame |
| | Tightening of side cover |
| | Tightening of rear fender |
| | Tightening of mud flap |
| | Tightening of rear brake disc cover |
| | Tightening of rear brake caliper cover |

TIP

Concerning the tightening torque, refer to "TIGHTENING TORQUES" on page 2-8.

EAM20126

MOTORCYCLE CARE AND STORAGE

EAM30200

CARE

While the open design of a motorcycle reveals the attractiveness of the technology, it also makes it more vulnerable. Rust and corrosion can develop even if high-quality components are used. A rusty exhaust pipe may go unnoticed on a car, however, it detracts from the overall appearance of a motorcycle. Frequent and proper care does not only comply with the terms of the warranty, but it will also keep your motorcycle looking good, extend its life and optimize its performance.

Before cleaning

TIP

Be sure to confirm that the vehicle is completely cooled.

1. Block or cover the following parts with suitable measures.
 - Air duct "1"
 - Drain hole on the cylinder head (right side) "2"
 - Hole under the water pump housing "3"
 - Muffler outlet "4"

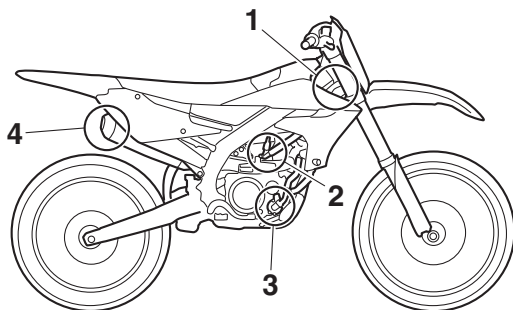

2. Make sure that all caps and covers as well as all electrical couplers and connectors, including the spark plug cap, are tightly installed.
3. Remove extremely stubborn dirt, like oil burnt onto the crankcase, with a degreasing agent and a brush, but never apply such products onto seals, gaskets, sprockets, the drive chain and wheel axles. Always rinse the dirt and degreaser off with water.

Cleaning

ECA26730

NOTICE

- Avoid using strong acidic wheel cleaners, especially on spoked wheels. If such products are used on hard-to-remove dirt, do not leave the cleaner on the affected area

any longer than instructed. Also, thoroughly rinse the area off with water, immediately dry it, and then apply a corrosion protection spray.

- Improper cleaning can damage plastic parts (such as cowlings, panels, windshields, headlight lenses, meter lenses, etc.) and the mufflers. Use only a soft, clean cloth or sponge with water to clean plastic. However, if the plastic parts cannot be thoroughly cleaned with water, diluted mild detergent with water may be used. Be sure to rinse off any detergent residue using plenty of water, as it is harmful to plastic parts.
- Do not use any harsh chemical products on plastic parts. Be sure to avoid using cloths or sponges which have been in contact with strong or abrasive cleaning products, solvent or thinner, fuel (gasoline), rust removers or inhibitors, brake fluid, antifreeze or electrolyte.
- For motorcycles equipped with a windshield: Do not use strong cleaners or hard sponges as they will cause dulling or scratching. Some cleaning compounds for plastic may leave scratches on the windshield. Test the product on a small hidden part of the windshield to make sure that it does not leave any marks. If the windshield is scratched, use a quality plastic polishing compound after washing.
- When cleaning using either a high-pressure cleaning machine or a water hose, do not direct the water jet toward the following areas: (Otherwise, it could cause either damage due to the water pressure or malfunction due to water entry.)
 - Wheels or swing arm bearings
 - Fork seals or brake seals
 - Electrical parts, such as couplers, switches, battery, etc.
 - Muffler or hoses
 - Air cleaner intake port
- Do not clean using a water jet with the seat or cover removed.

MOTORCYCLE CARE AND STORAGE

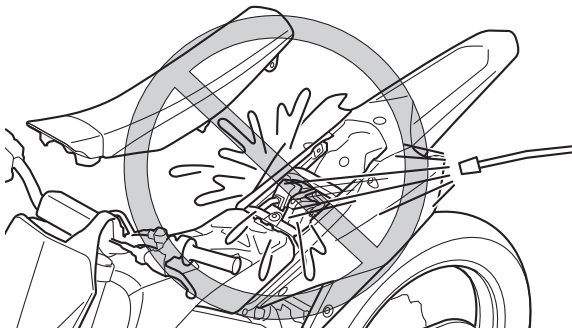

After normal use

Remove dirt with warm water, a mild detergent, and a soft, clean sponge, and then rinse thoroughly with clean water. Use a toothbrush or bottlebrush for hard-to-reach areas. Stubborn dirt and insects will come off more easily if the area is covered with a wet cloth for a few minutes before cleaning.

After riding in the rain, near the sea or on salt-sprayed roads

Since sea salt or salt sprayed on roads during winter are extremely corrosive in combination with water, carry out the following steps after each ride in the rain, near the sea or on salt-sprayed roads.

TIP

Salt sprayed on roads in the winter may remain well into spring.

1. Clean the motorcycle with cold water and a mild detergent, after the engine has cooled down.

NOTICE: Do not use warm water since it increases the corrosive action of the salt.

2. Apply a corrosion protection spray on all metal, including chrome- and nickel-plated, surfaces to prevent corrosion.

After cleaning

1. Dry the motorcycle with a chamois or an absorbing cloth.
2. Immediately dry the drive chain and lubricate it to prevent it from rusting.
3. Use a chrome polish to shine chrome, aluminum and stainless- steel parts, including the exhaust system. (Even the thermally induced discoloring of stainless- steel exhaust systems can be removed through polishing.)
4. To prevent corrosion, it is recommended to apply a corrosion protection spray on all metal, including chrome- and nickel-plated, surfaces.
5. Use spray oil as a universal cleaner to remove any remaining dirt.

6. Touch up minor paint damage caused by stones, etc.
7. Wax all painted surfaces.
8. Let the motorcycle dry completely before storing or covering it.

EWA19050

WARNING

Contaminants on the brakes or tires can cause loss of control.

- Make sure that there is no oil or wax on the brakes or tires.
- If necessary, clean the brake discs and brake linings with a regular brake disc cleaner or acetone, and wash the tires with warm water and a mild detergent. Before riding at higher speeds, test the motorcycle's braking performance and cornering behavior.

ECA24240

NOTICE

- Apply spray oil and wax sparingly and make sure to wipe off any excess.
- Never apply oil or wax to any rubber and plastic parts, but treat them with a suitable care product.
- Avoid using abrasive polishing compounds as they will wear away the paint.

TIP

- Consult a Yamaha dealer for advice on what products to use.
- Washing, rainy weather or humid climates can cause the headlight lens to fog. Turning the headlight on for a short period of time will help remove the moisture from the lens.

EAM30201

STORAGE

Short-term

Always store your motorcycle in a cool, dry place and, if necessary, protect it against dust with a porous cover. Be sure the engine and the exhaust system are cool before covering the motorcycle.

ECA24250

NOTICE

- Storing the motorcycle in a poorly ventilated room or covering it with a tarp, while it is still wet, will allow water and humidity to seep in and cause rust.
- To prevent corrosion, avoid damp cellars, stables (because of the presence of ammonia) and areas where strong chemicals are

stored.

Long-term

Before storing your motorcycle for several months:

1. Follow all the instructions in the “CARE” on page 1-28.
2. Fill up the fuel tank and add fuel stabilizer (if available) to prevent the fuel tank from rusting and the fuel from deteriorating.
3. Perform the following steps to protect the cylinder, piston rings, etc. from corrosion.
 - a. Remove the spark plug cap and spark plug.
 - b. Pour a teaspoonful of engine oil into the spark plug bore.
 - c. Install the spark plug cap onto the spark plug, and then place the spark plug on the cylinder head so that the electrodes are grounded. (This will limit sparking during the next step.)
 - d. Turn the engine over several times with the starter. (This will coat the cylinder wall with oil.)
 - e. Remove the spark plug cap from the spark plug, and then install the spark plug and the spark plug cap. **WARNING! To prevent damage or injury from sparking, make sure to ground the spark plug electrodes while turning the engine over.**
4. Lubricate all control cables and the pivoting points of all levers and pedals as well as of the sidestand/centerstand.
5. Check and, if necessary, correct the tire air pressure, and then lift the motorcycle so that both of its wheels are off the ground. Alternatively, turn the wheels a little every month in order to prevent the tires from becoming degraded in one spot.
6. Cover the muffler outlet with a plastic bag to prevent moisture from entering it.
7. Remove the battery and fully charge it. Store it in a cool, dry place and charge it once a month. Do not store the battery in an excessively cold or warm place [less than 0 °C (32 °F) or more than 30 °C (90 °F)]. For more information on storing the battery, “CHECKING AND CHARGING THE BATTERY” on page 7-4.

TIP

Make any necessary repairs before storing the motorcycle.

SPECIFICATIONS

| | |
|---|------|
| GENERAL SPECIFICATIONS | 2-1 |
| ENGINE SPECIFICATIONS | 2-2 |
| CHASSIS SPECIFICATIONS | 2-4 |
| ELECTRICAL SPECIFICATIONS | 2-7 |
| TIGHTENING TORQUES | 2-8 |
| GENERAL TIGHTENING TORQUE SPECIFICATIONS..... | 2-8 |
| ENGINE TIGHTENING TORQUES..... | 2-9 |
| CHASSIS TIGHTENING TORQUES..... | 2-12 |

GENERAL SPECIFICATIONS

EAM20127

GENERAL SPECIFICATIONS

Model

| | |
|-------|--|
| Model | BDB5 (AUS, NZL, ZAF) BDB7 (CAN) BDB8 (AUT, BEL, CHE, CYP, CZE, DEU, DNK, ESP, FIN, FRA, GBR, GRC, HRV, HUN, IRL, ITA, NLD, NOR, POL, PRT, SVK, SVN, SWE, TUR) |
|-------|--|

Dimensions

| | |
|------------------|-------------------|
| Overall length | 2175 mm (85.6 in) |
| Overall width | 825 mm (32.5 in) |
| Overall height | 1270 mm (50.0 in) |
| Seat height | 955 mm (37.6 in) |
| Wheelbase | 1480 mm (58.3 in) |
| Ground clearance | 320 mm (12.60 in) |

Weight

| | |
|-------------|-----------------|
| Curb weight | 119 kg (262 lb) |
|-------------|-----------------|

Shift up points

| | |
|-----------|------------------|
| 1st → 2nd | 20 km/h (12 mph) |
| 2nd → 3rd | 30 km/h (19 mph) |
| 3rd → 4th | 40 km/h (25 mph) |
| 4th → 5th | 50 km/h (31 mph) |

Shift down points

| | |
|------------------|------------------|
| 5th → 4th | 35 km/h (22 mph) |
| 4th → 3rd | 25 km/h (16 mph) |
| 3rd → 2nd | 25 km/h (16 mph) |
| 2nd → 1st | 25 km/h (16 mph) |
| Clutch off speed | 20 km/h (12 mph) |

ENGINE SPECIFICATIONS

EAM20128

ENGINE SPECIFICATIONS

Engine

| | |
|---------------------|---------------------------------|
| Combustion cycle | 4-stroke |
| Cooling system | Liquid cooled |
| Valve train | DOHC |
| Displacement | 450 cm ³ |
| Number of cylinders | Single cylinder |
| Bore × stroke | 97.0 × 60.8 mm (3.82 × 2.39 in) |
| Compression ratio | 13.0 : 1 |
| Starting system | Electric starter |

Fuel

| | |
|---------------------|------------------------------------|
| Recommended fuel | Unleaded gasoline (E10 acceptable) |
| Octane number (RON) | 95 |
| Fuel tank capacity | 7.9 L (2.1 US gal, 1.7 Imp.gal) |
| Fuel reserve amount | 2.0 L (0.53 US gal, 0.44 Imp.gal) |

Engine oil

| | |
|------------------------------|---|
| Recommended brand | YAMALUBE |
| SAE viscosity grades | 10W-40, 10W-50, 15W-40, 20W-40 or 20W-50 |
| Recommended engine oil grade | API service SG type or higher, JASO standard MA |
| Lubrication system | Wet sump |
| Engine oil quantity | |
| Oil change | 0.63 L (0.67 US qt, 0.55 Imp.qt) |
| With oil filter removal | 0.65 L (0.69 US qt, 0.57 Imp.qt) |
| Quantity (disassembled) | 0.90 L (0.95 US qt, 0.79 Imp.qt) |

Cooling system

| | |
|---------------------------------|----------------------------------|
| Coolant quantity | |
| Radiator (including all routes) | 1.03 L (1.09 US qt, 0.91 Imp.qt) |

Spark plug(s)

| | |
|--------------------|-----------------------------|
| Manufacturer/model | NGK/LMAR8G |
| Spark plug gap | 0.7–0.8 mm (0.028–0.031 in) |

Valve

| | |
|------------------------|---------------------------------|
| Valve clearance (cold) | |
| Intake | 0.10–0.17 mm (0.0039–0.0067 in) |
| Exhaust | 0.15–0.22 mm (0.0059–0.0087 in) |

Clutch

| | |
|---------------------------------|-------------------------------|
| Clutch type | Wet, multiple-disc |
| Clutch lever free play | 7.0–12.0 mm (0.28–0.47 in) |
| Friction plate 1 thickness | 2.92–3.08 mm (0.115–0.121 in) |
| Wear limit | 2.82 mm (0.111 in) |
| Plate quantity | 6 pcs |
| Friction plate 2 thickness | 2.92–3.08 mm (0.115–0.121 in) |
| Wear limit | 2.82 mm (0.111 in) |
| Plate quantity | 2 pcs |
| Clutch plate thickness | 1.50–1.70 mm (0.059–0.067 in) |
| Plate quantity | 7 pcs |
| Warping limit | 0.10 mm (0.004 in) |
| Clutch spring free length | 48.00 mm (1.89 in) |
| Clutch spring free length limit | 45.60 mm (1.80 in) |

ENGINE SPECIFICATIONS

| | |
|------------------------|--------------------|
| Push rod bending limit | 0.10 mm (0.004 in) |
|------------------------|--------------------|

| | |
|---------------------------|-----------------------|
| Drivetrain | |
| Primary reduction ratio | 2.609 (60/23) |
| Transmission type | Constant mesh 5-speed |
| Gear ratio | |
| 1st | 2.417 (29/12) |
| 2nd | 1.733 (26/15) |
| 3rd | 1.313 (21/16) |
| 4th | 1.050 (21/20) |
| 5th | 0.840 (21/25) |
| Secondary reduction ratio | 3.846 (50/13) |
| Final drive | Chain |

| | |
|----------------------|---|
| Air filter | |
| Air filter element | Wet element |
| Air filter oil grade | Yamaha foam air filter oil or other quality foam air filter oil |

| | |
|----------------------------|-----------------------------------|
| Idling condition | |
| Engine idling speed | 1900–2100 r/min |
| Exhaust gas sampling point | Sampling port on the exhaust pipe |
| Coolant temperature | 70–90 °C (158–194 °F) |
| CO% | 2.0–6.0 % |
| Intake vacuum | 35.8 kPa (269 mmHg, 10.6 inHg) |
| Throttle grip free play | 3.0–6.0 mm (0.12–0.24 in) |

CHASSIS SPECIFICATIONS

EAM20129

CHASSIS SPECIFICATIONS

Chassis

| | |
|--------------|-----------------|
| Caster angle | 27.2 ° |
| Trail | 116 mm (4.6 in) |

Front wheel

| | |
|------------|-------------|
| Wheel type | Spoke wheel |
| Rim size | 21 x 1.60 |

Rear wheel

| | |
|------------|-------------|
| Wheel type | Spoke wheel |
| Rim size | 18 x 2.15 |

Front tire

| | |
|--------------------|---|
| Type | With tube |
| Size | 80/100-21 51M (CAN) 90/90-21 54R (AUS, AUT, BEL, CHE, CYP, CZE, DEU, DNK, ESP, FIN, FRA, GBR, GRC, HRV, HUN, IRL, ITA, NLD, NOR, NZL, POL, PRT, SVK, SVN, SWE, TUR, ZAF) |
| Manufacturer/model | DUNLOP/EN91F (AUS, AUT, BEL, CHE, CYP, CZE, DEU, DNK, ESP, FIN, FRA, GBR, GRC, HRV, HUN, IRL, ITA, NLD, NOR, NZL, POL, PRT, SVK, SVN, SWE, TUR, ZAF) DUNLOP/MX33F (CAN) |

Rear tire

| | |
|--------------------|--|
| Type | With tube |
| Size | 120/90-18 65M (CAN) 140/80-18 70R (AUS, AUT, BEL, CHE, CYP, CZE, DEU, DNK, ESP, FIN, FRA, GBR, GRC, HRV, HUN, IRL, ITA, NLD, NOR, NZL, POL, PRT, SVK, SVN, SWE, TUR, ZAF) |
| Manufacturer/model | DUNLOP/EN91 (AUS, AUT, BEL, CHE, CYP, CZE, DEU, DNK, ESP, FIN, FRA, GBR, GRC, HRV, HUN, IRL, ITA, NLD, NOR, NZL, POL, PRT, SVK, SVN, SWE, TUR, ZAF) DUNLOP/MX33 (CAN) |

Tire air pressure (measured on cold tires)

| | |
|-------|---|
| Front | 100 kPa (1.00 kgf/cm ² , 15 psi) |
| Rear | 100 kPa (1.00 kgf/cm ² , 15 psi) |

Front brake

| | |
|----------------------------------|-----------------------------|
| Type | Hydraulic single disc brake |
| Brake pad lining thickness limit | 1.0 mm (0.04 in) |
| Specified brake fluid | DOT 4 |

Rear brake

| | |
|----------------------------------|-----------------------------|
| Type | Hydraulic single disc brake |
| Brake pad lining thickness limit | 1.0 mm (0.04 in) |
| Specified brake fluid | DOT 4 |

Front suspension

| | |
|--------|-----------------|
| Type | Telescopic fork |
| Spring | Coil spring |

CHASSIS SPECIFICATIONS

| | |
|---|---|
| Shock absorber | Hydraulic damper |
| Wheel travel | 310 mm (12.2 in) |
| Fork spring free length limit | 492.0 mm (19.37 in) |
| Inner tube bending limit | 0.2 mm (0.01 in) |
| Recommended oil | Yamaha Suspension Oil S1 |
| Quantity (left) | 491.0 cm ³ (16.60 US oz, 17.32 Imp.oz) |
| Quantity (right) | 491.0 cm ³ (16.60 US oz, 17.32 Imp.oz) |
| Rebound damping | |
| Adjusting system | Mechanical adjustable type |
| Unit for adjustment | Click |
| Adjustment value from the start position (Soft) | 20 |
| Adjustment value from the start position (STD) | 8 |
| Adjustment value from the start position (Hard) | 0 |
| Compression damping | |
| Adjusting system | Mechanical adjustable type |
| Unit for compression damping adjustment | Click |
| Adjustment value from the start position (Soft) | 20 |
| Adjustment value from the start position (STD) | 12 |
| Adjustment value from the start position (Hard) | 0 |

Rear suspension

| | |
|---|----------------------------|
| Type | Swingarm (link suspension) |
| Spring | Coil spring |
| Shock absorber | Gas-hydraulic damper |
| Wheel travel | 317 mm (12.5 in) |
| Spring preload | |
| Adjusting system | Mechanical adjustable type |
| Adjustment value (Soft) | 1.5 mm (0.06 in) |
| Adjustment value (STD) | 10.0 mm (0.39 in) |
| Adjustment value (Hard) | 18.0 mm (0.71 in) |
| Rebound damping | |
| Adjusting system | Mechanical adjustable type |
| Unit for adjustment | Click |
| Adjustment value from the start position (Soft) | 30 |
| Adjustment value from the start position (STD) | 8 |
| Adjustment value from the start position (Hard) | 0 |
| Compression damping | |
| Adjusting system | Mechanical adjustable type |
| Fast compression damping | |
| Unit for adjustment | Turn |
| Adjustment value from the start position (Soft) | 2 |
| Adjustment value from the start position (STD) | 1 |

CHASSIS SPECIFICATIONS

| | |
|--|-------|
| Adjustment value from the start position (Hard) | 0 |
| Slow compression damping | |
| Unit for adjustment | Click |
| Adjustment value from the start position (Soft) | 20 |
| Adjustment value from the start position (STD) | 10 |
| Adjustment value from the start position (Hard) | 0 |

Drive chain

| | |
|---------------------------------------|-----------------------------|
| Size | 520 |
| Chain type | Sealed type |
| Number of links | 114 |
| Drive chain slack (Maintenance Stand) | 50.0–60.0 mm (1.97–2.36 in) |
| 15-link length limit | 239.3 mm (9.42 in) |

ELECTRICAL SPECIFICATIONS

EAM20130

ELECTRICAL SPECIFICATIONS

Battery

| | |
|-------------------|----------------------|
| Model | YTZ7S(F) |
| Voltage, capacity | 12 V, 6.0 Ah (10 HR) |

Headlight

| | |
|-----------|--------------|
| Bulb type | Halogen bulb |
|-----------|--------------|

Bulb wattage

| | |
|------------------|-------------------------|
| Headlight | HS1, 35.0 W/35.0 W |
| Brake/tail light | LED |
| Meter lighting | EL (Electroluminescent) |

Indicator light

| | |
|------------------------------|-----|
| Fuel level warning light | LED |
| Engine trouble warning light | LED |

Fuse(s)

| | |
|-------------------------|--------|
| Main fuse | 15.0 A |
| Radiator fan motor fuse | 5.0 A |
| Spare fuse | 15.0 A |

EAM20131

TIGHTENING TORQUES

EAM30205

GENERAL TIGHTENING TORQUE SPECIFICATIONS

This chart specifies tightening torques for standard fasteners with a standard ISO thread pitch. Tightening torque specifications for special components or assemblies are provided for each chapter of this manual. To avoid warpage, tighten multi-fastener assemblies in a crisscross pattern and progressive stages until the specified tightening torque is reached. Unless otherwise specified, tightening torque specifications require clean, dry threads. Components should be at room temperature.

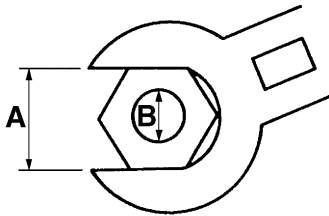

- A. Distance between flats
- B. Outside thread diameter

| A (nut) | B (bolt) | General tightening torques | | |
|---------|----------|----------------------------|-------|-------|
| | | N·m | kgf·m | lb·ft |
| 10 mm | 6 mm | 6 | 0.6 | 4.4 |
| 12 mm | 8 mm | 15 | 1.5 | 11 |
| 14 mm | 10 mm | 30 | 3.0 | 22 |
| 17 mm | 12 mm | 55 | 5.5 | 41 |
| 19 mm | 14 mm | 85 | 8.5 | 63 |
| 22 mm | 16 mm | 130 | 13.0 | 96 |









TIGHTENING TORQUES

EAM30203









ENGINE TIGHTENING TORQUES

TIP







△- marked portion shall be checked for torque tightening after break-in or before each race.

| Item | Thread size | Q'ty | Tightening torques | Remarks |
|---|-------------|------|---------------------------------|---|
| Camshaft cap bolt | M6 | 7 | 10 N·m (1.0 kgf·m, 7.4 lb·ft) |  |
| Spark plug | M10 | 1 | 13 N·m (1.3 kgf·m, 9.6 lb·ft) | |
| Oil passage plug (cylinder head) | M6 | 2 | 10 N·m (1.0 kgf·m, 7.4 lb·ft) |  |
| Cylinder head bolt | M10 | 4 | See TIP. |  |
| Cylinder head bolt | M6 | 2 | 10 N·m (1.0 kgf·m, 7.4 lb·ft) | |
| Cylinder head cover bolt | M6 | 3 | 10 N·m (1.0 kgf·m, 7.4 lb·ft) | |
| Cylinder head stud bolt (exhaust pipe) | M6 | 2 | 7 N·m (0.7 kgf·m, 5.2 lb·ft) | |
| Stud bolt (cylinder head cover) | M6 | 1 | 10 N·m (1.0 kgf·m, 7.4 lb·ft) |  |
| Cylinder head cover breather plate bolt | M6 | 2 | 10 N·m (1.0 kgf·m, 7.4 lb·ft) |  |
| Oil nozzle | M6 | 1 | 3.0 N·m (0.30 kgf·m, 2.2 lb·ft) | |
| Cylinder bolt | M6 | 1 | 10 N·m (1.0 kgf·m, 7.4 lb·ft) | |
| Balancer weight plate screw | M6 | 3 | 10 N·m (1.0 kgf·m, 7.4 lb·ft) |  |
| Balancer weight gear nut | M14 | 1 | 50 N·m (5.0 kgf·m, 37 lb·ft) | Use a lock washer. |
| Balancer nut | M10 | 1 | 45 N·m (4.5 kgf·m, 33 lb·ft) | Use a lock washer. |
| Timing chain guide stopper plate (exhaust side) | M6 | 1 | 10 N·m (1.0 kgf·m, 7.4 lb·ft) |  |
| Timing chain tensioner cap bolt | M6 | 1 | 6 N·m (0.6 kgf·m, 4.4 lb·ft) | |
| Timing chain tensioner bolt | M6 | 2 | 10 N·m (1.0 kgf·m, 7.4 lb·ft) | |
| Coolant drain bolt | M6 | 1 | 10 N·m (1.0 kgf·m, 7.4 lb·ft) | |
| Radiator hose clamp screw | M6 | 8 | 1.5 N·m (0.15 kgf·m, 1.1 lb·ft) | |
| Radiator bolt | M6 | 4 | 10 N·m (1.0 kgf·m, 7.4 lb·ft) | |
| Radiator pipe joint bolt | M6 | 1 | 10 N·m (1.0 kgf·m, 7.4 lb·ft) | |
| Radiator fan bolt | M6 | 3 | 8 N·m (0.8 kgf·m, 5.9 lb·ft) | |
| Water pump housing cover bolt | M6 | 4 | 10 N·m (1.0 kgf·m, 7.4 lb·ft) | |
| Oil pump assembly bolt | M5 | 2 | 5 N·m (0.5 kgf·m, 3.7 lb·ft) |  |
| Oil pump cover bolt | M4 | 1 | 6 N·m (0.6 kgf·m, 4.4 lb·ft) |  |
| Oil strainer bolt | M6 | 1 | 10 N·m (1.0 kgf·m, 7.4 lb·ft) | |
| Throttle cable cover bolt | M5 | 1 | 3.5 N·m (0.35 kgf·m, 2.6 lb·ft) | |
| Throttle body joint bolt | M6 | 2 | 10 N·m (1.0 kgf·m, 7.4 lb·ft) | |
| Throttle body joint clamp screw | M5 | 1 | 3.0 N·m (0.30 kgf·m, 2.2 lb·ft) | |
| Air filter case joint clamp screw | M5 | 1 | 3.0 N·m (0.30 kgf·m, 2.2 lb·ft) | |

TIGHTENING TORQUES

| Item | Thread size | Q'ty | Tightening torques | Remarks |
|--|-------------|------|---------------------------------|---|
| Air filter case bolt | M6 | 3 | 7 N·m (0.7 kgf·m, 5.2 lb·ft) | |
| Clutch cable locknut (clutch cable adjuster) | M6 | 1 | 4.3 N·m (0.43 kgf·m, 3.2 lb·ft) | |
| Clutch cable locknut (engine side) | M8 | 1 | 7 N·m (0.7 kgf·m, 5.2 lb·ft) | |
| Exhaust pipe nut | M6 | 2 | 10 N·m (1.0 kgf·m, 7.4 lb·ft) | |
| Exhaust pipe protector screw | M6 | 2 | 10 N·m (1.0 kgf·m, 7.4 lb·ft) |  |
| Exhaust pipe bracket bolt | M8 | 1 | 20 N·m (2.0 kgf·m, 15 lb·ft) | |
| Silencer bolt (front) | M8 | 1 | 30 N·m (3.0 kgf·m, 22 lb·ft) | |
| Silencer bolt (rear) | M8 | 1 | 30 N·m (3.0 kgf·m, 22 lb·ft) | |
| Exhaust pipe clamp bolt | M8 | 2 | 12 N·m (1.2 kgf·m, 8.9 lb·ft) | |
| Spark arrester bolt | M5 | 4 | 9 N·m (0.9 kgf·m, 6.6 lb·ft) | |
| Silencer cap screw | M5 | 6 | 5 N·m (0.5 kgf·m, 3.7 lb·ft) | |
| Oil nozzle bolt | M6 | 1 | 10 N·m (1.0 kgf·m, 7.4 lb·ft) |  |
| Engine oil drain bolt | M10 | 1 | 20 N·m (2.0 kgf·m, 15 lb·ft) | |
| Crankcase bolt | M6 | 12 | 12 N·m (1.2 kgf·m, 8.9 lb·ft) | |
| Clutch cable holder bolt | M6 | 2 | 10 N·m (1.0 kgf·m, 7.4 lb·ft) |  |
| Crankshaft end accessing screw | M36 | 1 | 10 N·m (1.0 kgf·m, 7.4 lb·ft) | |
| Timing mark accessing screw | M14 | 1 | 6 N·m (0.6 kgf·m, 4.4 lb·ft) | |
| Drive sprocket cover bolt | M6 | 2 | 7 N·m (0.7 kgf·m, 5.2 lb·ft) | |
| Crankcase bearing cover plate screw | M8 | 4 | 22 N·m (2.2 kgf·m, 16 lb·ft) |  |
| Bearing plate cover bolt (left side of the drive axle) | M6 | 2 | 12 N·m (1.2 kgf·m, 8.9 lb·ft) |  |
| Plate bolt | M6 | 4 | 12 N·m (1.2 kgf·m, 8.9 lb·ft) |  |
| Starter motor cover bolt | M6 | 1 | 10 N·m (1.0 kgf·m, 7.4 lb·ft) | |
| Clutch cover bolt | M6 | 7 | 10 N·m (1.0 kgf·m, 7.4 lb·ft) | |
| Crankcase cover bolt (left) | M6 | 7 | 10 N·m (1.0 kgf·m, 7.4 lb·ft) | |
| Crankcase cover bolt (right) | M6 | 11 | 10 N·m (1.0 kgf·m, 7.4 lb·ft) | |
| Oil filter element cover bolt | M6 | 2 | 10 N·m (1.0 kgf·m, 7.4 lb·ft) | |
| Starter clutch idle gear holder bolt | M6 | 2 | 12 N·m (1.2 kgf·m, 8.9 lb·ft) |  |
| Primary drive gear nut | M20 | 1 | 80 N·m (8.0 kgf·m, 59 lb·ft) | |
| Clutch spring bolt | M6 | 6 | 10 N·m (1.0 kgf·m, 7.4 lb·ft) | |
| Clutch boss nut | M20 | 1 | 75 N·m (7.5 kgf·m, 55 lb·ft) | Use a lock washer.  |
| Drive sprocket nut | M20 | 1 | 90 N·m (9.0 kgf·m, 66 lb·ft) | Use a lock washer. |
| Segment | M8 | 1 | 30 N·m (3.0 kgf·m, 22 lb·ft) | |

TIGHTENING TORQUES

| Item | Thread size | Q'ty | Tightening torques | Remarks |
|---------------------------------------|-------------|------|---------------------------------|---|
| Shift guide bolt | M6 | 2 | 10 N·m (1.0 kgf·m, 7.4 lb·ft) |  |
| Stopper lever bolt | M6 | 1 | 10 N·m (1.0 kgf·m, 7.4 lb·ft) |  |
| Shift pedal bolt | M6 | 1 | 12 N·m (1.2 kgf·m, 8.9 lb·ft) | △ |
| Generator rotor nut | M12 | 1 | 65 N·m (6.5 kgf·m, 48 lb·ft) | |
| Stator coil screw | M5 | 3 | 10 N·m (1.0 kgf·m, 7.4 lb·ft) |  |
| Crankshaft position sensor bolt | M6 | 2 | 10 N·m (1.0 kgf·m, 7.4 lb·ft) |  |
| Stator coil assembly lead holder bolt | M5 | 1 | 8 N·m (0.8 kgf·m, 5.9 lb·ft) |  |
| Coolant temperature sensor | M10 | 1 | 15 N·m (1.5 kgf·m, 11 lb·ft) | |
| Gear position switch bolt | M5 | 2 | 3.5 N·m (0.35 kgf·m, 2.6 lb·ft) |  |
| Rectifier/regulator bolt | M6 | 2 | 7 N·m (0.7 kgf·m, 5.2 lb·ft) | |
| ECU bolt | M5 | 2 | 3.8 N·m (0.38 kgf·m, 2.8 lb·ft) | |
| Ignition coil bolt | M6 | 2 | 7 N·m (0.7 kgf·m, 5.2 lb·ft) | |
| Starter motor bolt | M6 | 2 | 10 N·m (1.0 kgf·m, 7.4 lb·ft) | |
| Nut (holder) | M6 | 1 | 8 N·m (0.8 kgf·m, 5.9 lb·ft) | |
| Throttle position sensor screw | M5 | 1 | 3.5 N·m (0.35 kgf·m, 2.6 lb·ft) | |
| Intake air pressure sensor screw | M6 | 1 | 3.5 N·m (0.35 kgf·m, 2.6 lb·ft) | |

TIP

Cylinder head bolt

First, tighten the cylinder head bolts to 40 N·m (4.0 kgf·m, 30 lb·ft) in the proper tightening sequence and remove them. Retighten the cylinder head bolts to 23 N·m (2.3 kgf·m, 17 lb·ft) in the proper tightening sequence. Tighten all bolts to reach the specified angle (90°) in a diagonal sequence, and then tighten the cylinder head bolts further to reach the specified angle (60°) in the proper tightening sequence. (The first and second time, be sure to apply molybdenum disulfide grease to the bolt threads and seats as well as to both sides of the washers.)

TIGHTENING TORQUES

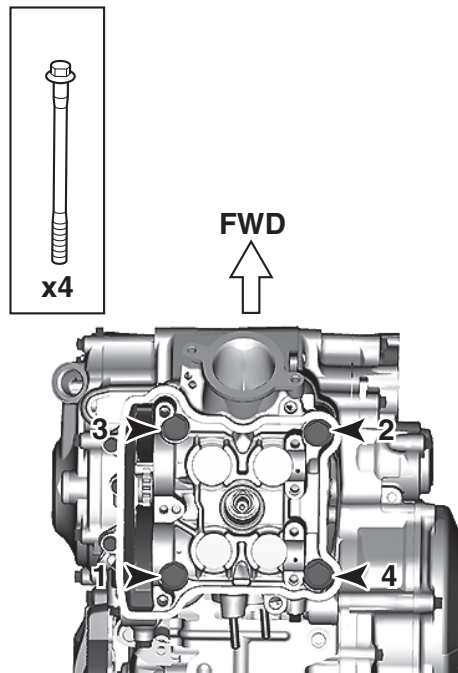

EAM30204





CHASSIS TIGHTENING TORQUES

TIP

△- marked portion shall be checked for torque tightening after break-in or before each race.

| Item | Thread size | Q'ty | Tightening torques | Remarks |
|---|-------------|------|----------------------------------|---|
| Upper bracket pinch bolt | M8 | 4 | 21 N·m (2.1 kgf·m, 15 lb·ft) | △ |
| Lower bracket pinch bolt | M8 | 4 | 21 N·m (2.1 kgf·m, 15 lb·ft) | △ |
| Steering stem nut | M24 | 1 | 145 N·m (14.5 kgf·m, 107 lb·ft) | △ |
| Upper handlebar holder bolt | M8 | 4 | 28 N·m (2.8 kgf·m, 21 lb·ft) | △ |
| Lower handlebar holder nut | M10 | 2 | 40 N·m (4.0 kgf·m, 30 lb·ft) | △ |
| Engine stop switch screw | M3 | 1 | 0.5 N·m (0.05 kgf·m, 0.37 lb·ft) | |
| Start switch | M3 | 1 | 0.5 N·m (0.05 kgf·m, 0.37 lb·ft) | |
| Mode switch (Except for Canada) | M3 | 1 | 1.3 N·m (0.13 kgf·m, 0.95 lb·ft) | |
| Lower ring nut | M28 | 1 | See TIP. | △ |
| Damper assembly (front fork) | M51 | 2 | 30 N·m (3.0 kgf·m, 22 lb·ft) | |
| Inner tube and adjuster | M22 | 2 | 55 N·m (5.5 kgf·m, 41 lb·ft) |  |
| Base valve (front fork) | M42 | 2 | 28 N·m (2.8 kgf·m, 21 lb·ft) | |
| Adjuster (damper assembly) | M12 | 2 | 29 N·m (2.9 kgf·m, 21 lb·ft) | |
| Bleed screw (front fork) | M5 | 2 | 1.3 N·m (0.13 kgf·m, 0.95 lb·ft) | |
| Front fork protector bolt | M6 | 6 | 5 N·m (0.5 kgf·m, 3.7 lb·ft) | △ |
| Speed sensor lead holder and speed sensor lead bracket bolt | M6 | 1 | 7 N·m (0.7 kgf·m, 5.2 lb·ft) | |
| Plate bolt | M5 | 2 | 3.8 N·m (0.38 kgf·m, 2.8 lb·ft) | △ |

TIGHTENING TORQUES

| Item | Thread size | Q'ty | Tightening torques | Remarks |
|---|-------------|------|---------------------------------|---|
| Throttle grip cap screw | M5 | 2 | 3.8 N·m (0.38 kgf·m, 2.8 lb·ft) | |
| Clutch lever holder bolt | M5 | 2 | 3.8 N·m (0.38 kgf·m, 2.8 lb·ft) | |
| Clutch lever nut | M6 | 1 | 4.0 N·m (0.40 kgf·m, 3.0 lb·ft) | |
| Front brake master cylinder holder bolt | M6 | 2 | 9 N·m (0.9 kgf·m, 6.6 lb·ft) | △ |
| Front brake master cylinder reservoir cap screw | M4 | 2 | 1.5 N·m (0.15 kgf·m, 1.1 lb·ft) | |
| Front brake lever pivot bolt | M6 | 1 | 6 N·m (0.6 kgf·m, 4.4 lb·ft) | |
| Front brake lever pivot nut | M6 | 1 | 6 N·m (0.6 kgf·m, 4.4 lb·ft) | |
| Locknut (front brake lever position) | M6 | 1 | 5 N·m (0.5 kgf·m, 3.7 lb·ft) | |
| Front brake hose guide bolt | M5 | 1 | 3.8 N·m (0.38 kgf·m, 2.8 lb·ft) | △ |
| Front brake hose union bolt | M10 | 2 | 30 N·m (3.0 kgf·m, 22 lb·ft) | △ |
| Front brake caliper bolt | M8 | 2 | 28 N·m (2.8 kgf·m, 21 lb·ft) | △ |
| Front brake pad pin | M10 | 1 | 17 N·m (1.7 kgf·m, 13 lb·ft) | |
| Front brake pad pin plug | M10 | 1 | 2.5 N·m (0.25 kgf·m, 1.8 lb·ft) | |
| Front brake caliper bleed screw | M8 | 1 | 5 N·m (0.5 kgf·m, 3.7 lb·ft) | △ |
| Front wheel axle nut | M18 | 1 | 115 N·m (11.5 kgf·m, 85 lb·ft) | △ |
| Front wheel axle pinch bolt | M8 | 4 | 21 N·m (2.1 kgf·m, 15 lb·ft) | △ |
| Front brake disc bolt | M6 | 6 | 12 N·m (1.2 kgf·m, 8.9 lb·ft) | △/—  |
| Rear brake disc bolt | M6 | 6 | 12 N·m (1.2 kgf·m, 8.9 lb·ft) | △/—  |
| Footrest bracket bolt | M10 | 4 | 55 N·m (5.5 kgf·m, 41 lb·ft) |  |
| Sidestand bolt | M10 | 1 | 35 N·m (3.5 kgf·m, 26 lb·ft) |  |
| Rear brake pedal bolt | M8 | 1 | 26 N·m (2.6 kgf·m, 19 lb·ft) | △ |
| Rear brake pedal adjusting locknut | M6 | 1 | 6 N·m (0.6 kgf·m, 4.4 lb·ft) | |
| Rear brake master cylinder bolt | M6 | 2 | 10 N·m (1.0 kgf·m, 7.4 lb·ft) | △ |
| Rear brake master cylinder reservoir cap bolt | M4 | 2 | 1.5 N·m (0.15 kgf·m, 1.1 lb·ft) | |
| Rear brake hose union bolt | M10 | 2 | 30 N·m (3.0 kgf·m, 22 lb·ft) | △ |
| Rear brake caliper bleed screw | M8 | 1 | 5 N·m (0.5 kgf·m, 3.7 lb·ft) | △ |
| Rear brake pad pin | M10 | 1 | 17 N·m (1.7 kgf·m, 13 lb·ft) | |
| Rear brake pad pin plug | M10 | 1 | 2.5 N·m (0.25 kgf·m, 1.8 lb·ft) | |
| Rear wheel axle nut | M20 | 1 | 125 N·m (12.5 kgf·m, 92 lb·ft) | △ |
| Drive chain puller locknut | M8 | 2 | 21 N·m (2.1 kgf·m, 15 lb·ft) | |
| Rear wheel sprocket nut | M8 | 6 | 50 N·m (5.0 kgf·m, 37 lb·ft) | △ |
| Nipple (spoke) | — | 72 | 2.5 N·m (0.25 kgf·m, 1.8 lb·ft) | △ |
| Bolt (rear brake disc cover) | M6 | 2 | 10 N·m (1.0 kgf·m, 7.4 lb·ft) | △ |
| Rear brake caliper protector bolt | M6 | 2 | 7 N·m (0.7 kgf·m, 5.2 lb·ft) | △ |

TIGHTENING TORQUES

| Item | Thread size | Q'ty | Tightening torques | Remarks |
|---|-------------|------|---------------------------------|---------|
| Engine mounting bolt (upper side) | M10 | 2 | 45 N·m (4.5 kgf·m, 33 lb·ft) | △ |
| Engine mounting nut (front side) | M10 | 1 | 55 N·m (5.5 kgf·m, 41 lb·ft) | △ |
| Engine mounting nut (lower side) | M10 | 1 | 53 N·m (5.3 kgf·m, 39 lb·ft) | △ |
| Engine bracket bolt (upper side) | M8 | 4 | 34 N·m (3.4 kgf·m, 25 lb·ft) | △ |
| Engine bracket bolt (front side) | M8 | 4 | 34 N·m (3.4 kgf·m, 25 lb·ft) | △ |
| Rear frame bolt | M8 | 4 | 38 N·m (3.8 kgf·m, 28 lb·ft) | △ |
| Engine guard bolt | M6 | 3 | 7 N·m (0.7 kgf·m, 5.2 lb·ft) | △ |
| Pivot shaft nut | M16 | 1 | 85 N·m (8.5 kgf·m, 63 lb·ft) | △ |
| Rear shock absorber assembly upper nut | M10 | 1 | 56 N·m (5.6 kgf·m, 41 lb·ft) | △ |
| Rear shock absorber assembly lower nut | M10 | 1 | 53 N·m (5.3 kgf·m, 39 lb·ft) | △ |
| Locknut (rear shock absorber lock-nut) | M60 | 1 | 10 N·m (1.0 kgf·m, 7.4 lb·ft) | |
| Relay arm nut (swingarm side) | M14 | 1 | 70 N·m (7.0 kgf·m, 52 lb·ft) | △ |
| Connecting arm nut (relay arm side) | M14 | 1 | 80 N·m (8.0 kgf·m, 59 lb·ft) | △ |
| Connecting arm nut (frame side) | M14 | 1 | 80 N·m (8.0 kgf·m, 59 lb·ft) | △ |
| Brake hose holder screw | M5 | 4 | 3.5 N·m (0.35 kgf·m, 2.6 lb·ft) | △ |
| Drive chain tensioner bolt (upper side) | M8 | 1 | 16 N·m (1.6 kgf·m, 12 lb·ft) | |
| Drive chain tensioner bolt (lower side) | M8 | 1 | 16 N·m (1.6 kgf·m, 12 lb·ft) | |
| Bolt (drive chain support) | M6 | 1 | 7 N·m (0.7 kgf·m, 5.2 lb·ft) | |
| Drive chain support nut | M6 | 2 | 7 N·m (0.7 kgf·m, 5.2 lb·ft) | |
| Drive chain guide bolt | M5 | 3 | 4.0 N·m (0.40 kgf·m, 3.0 lb·ft) | |
| Fuel tank bolt (front side) | M6 | 2 | 7 N·m (0.7 kgf·m, 5.2 lb·ft) | △ |
| Fuel tank bolt (boss) | M6 | 2 | 7 N·m (0.7 kgf·m, 5.2 lb·ft) | △ |
| Fuel tank bolt (rear side) | M6 | 1 | 9 N·m (0.9 kgf·m, 6.6 lb·ft) | |
| Fuel tank bracket bolt | M6 | 2 | 7 N·m (0.7 kgf·m, 5.2 lb·ft) | |
| Fuel pump bolt | M5 | 5 | 7 N·m (0.7 kgf·m, 5.2 lb·ft) | △ |
| Screw (fuel inlet pipe) | M5 | 2 | 3.5 N·m (0.35 kgf·m, 2.6 lb·ft) | |
| Bolt (fuel tank cap cover) | M6 | 2 | 4.0 N·m (0.40 kgf·m, 3.0 lb·ft) | |
| Seat set bracket screw | M6 | 1 | 7 N·m (0.7 kgf·m, 5.2 lb·ft) | |
| Seat bolt | M8 | 2 | 22 N·m (2.2 kgf·m, 16 lb·ft) | △ |
| Side cover bolt (left) | M6 | 2 | 7 N·m (0.7 kgf·m, 5.2 lb·ft) | △ |
| Side cover bolt (right) | M6 | 2 | 7 N·m (0.7 kgf·m, 5.2 lb·ft) | △ |
| Air scoop bolt (frame) | M6 | 2 | 7 N·m (0.7 kgf·m, 5.2 lb·ft) | △ |
| Air scoop bolt (fuel tank) | M6 | 2 | 7 N·m (0.7 kgf·m, 5.2 lb·ft) | △ |
| Air scoop bolt (radiator guard) | M6 | 4 | 7 N·m (0.7 kgf·m, 5.2 lb·ft) | △ |

TIGHTENING TORQUES

| Item | Thread size | Q'ty | Tightening torques | Remarks |
|---|-------------|------|----------------------------------|---------|
| Front fender bolt | M6 | 4 | 10 N·m (1.0 kgf·m, 7.4 lb·ft) | △ |
| Rear fender bolt (front side) | M6 | 4 | 7 N·m (0.7 kgf·m, 5.2 lb·ft) | △ |
| Rear fender bolt (rear side) | M6 | 2 | 16 N·m (1.6 kgf·m, 12 lb·ft) | △ |
| Headlight body and headlight stay bolt | M6 | 2 | 7 N·m (0.7 kgf·m, 5.2 lb·ft) | |
| Multi-function meter screw | M5 | 2 | 1.3 N·m (0.13 kgf·m, 0.95 lb·ft) | |
| Multi-function meter bracket bolt | M6 | 1 | 7 N·m (0.7 kgf·m, 5.2 lb·ft) | |
| Screw (mud flap) | — | 2 | 1.3 N·m (0.13 kgf·m, 0.95 lb·ft) | △ |
| Frame ground bolt (negative battery lead) | M5 | 1 | 7 N·m (0.7 kgf·m, 5.2 lb·ft) | |
| Front reflector nut (For Canada) | M6 | 2 | 3.8 N·m (0.38 kgf·m, 2.8 lb·ft) | |
| Rear reflector nut (For Canada) | M5 | 1 | 1.8 N·m (0.18 kgf·m, 1.3 lb·ft) | |
| Side reflector nut (For Canada) | M5 | 2 | 1.8 N·m (0.18 kgf·m, 1.3 lb·ft) | |

TIP

Lower ring nut

1. First, tighten the lower ring nut approximately 38 N·m (3.8 kgf·m, 28 lb·ft) by using the steering nut wrench, then loosen the lower ring nut one turn.
2. Retighten the lower ring nut 7 N·m (0.7 kgf·m, 5.2 lb·ft).

PERIODIC CHECKS AND ADJUSTMENTS

| | |
|--|------|
| PERIODIC MAINTENANCE | 3-1 |
| INTRODUCTION | 3-1 |
| PERIODIC MAINTENANCE CHART FOR THE EMISSION CONTROL SYSTEM | 3-1 |
| GENERAL MAINTENANCE AND LUBRICATION CHART | 3-1 |
| MAINTENANCE INTERVALS FOR COMPETITION USE | 3-3 |
| | |
| PRE-OPERATION INSPECTION AND MAINTENANCE | 3-6 |
| GENERAL INSPECTION AND MAINTENANCE | 3-6 |
| | |
| ENGINE | 3-7 |
| ADJUSTING THE VALVE CLEARANCE | 3-7 |
| CHECKING THE ENGINE IDLING SPEED | 3-8 |
| CHECKING THE THROTTLE GRIP | 3-8 |
| CHECKING THE SPARK PLUG | 3-9 |
| CHECKING THE ENGINE OIL LEVEL | 3-10 |
| CHANGING THE ENGINE OIL | 3-10 |
| ADJUSTING THE CLUTCH LEVER FREE PLAY | 3-12 |
| CLEANING THE AIR FILTER ELEMENT | 3-12 |
| CHECKING THE THROTTLE BODY JOINT | 3-14 |
| CHECKING THE FUEL LINE | 3-14 |
| CHECKING THE CYLINDER HEAD BREATHER HOSE | 3-15 |
| CHECKING THE EXHAUST SYSTEM | 3-15 |
| CHECKING THE COOLANT LEVEL | 3-16 |
| CHECKING THE COOLING SYSTEM | 3-17 |
| CHANGING THE COOLANT | 3-17 |
| | |
| CHASSIS | 3-19 |
| ADJUSTING THE FRONT DISC BRAKE | 3-19 |
| ADJUSTING THE REAR DISC BRAKE | 3-19 |
| CHECKING THE BRAKE FLUID LEVEL | 3-19 |
| CHECKING THE FRONT BRAKE PADS | 3-20 |
| CHECKING THE REAR BRAKE PADS | 3-20 |
| CHECKING THE FRONT BRAKE HOSE | 3-20 |
| CHECKING THE REAR BRAKE HOSE | 3-20 |
| CHECKING THE BRAKE OPERATION | 3-21 |
| BLEEDING THE HYDRAULIC BRAKE SYSTEM | 3-21 |
| DRIVE CHAIN SLACK | 3-22 |
| LUBRICATING THE DRIVE CHAIN | 3-22 |
| CHECKING AND ADJUSTING THE STEERING HEAD | 3-23 |
| LUBRICATING THE STEERING HEAD | 3-24 |
| CHECKING THE FRONT FORK LEGS | 3-24 |
| ADJUSTING THE FRONT FORK LEGS | 3-25 |
| CHECKING THE REAR SHOCK ABSORBER ASSEMBLY | 3-26 |
| ADJUSTING THE REAR SHOCK ABSORBER ASSEMBLY | 3-26 |
| CHECKING THE SWINGARM OPERATION | 3-28 |
| LUBRICATING THE SWINGARM PIVOT | 3-28 |
| CHECKING THE TIRES | 3-28 |

| | |
|---|-------------|
| CHECKING AND TIGHTENING THE SPOKES..... | 3-29 |
| CHECKING THE WHEELS | 3-29 |
| CHECKING THE CHASSIS FASTENERS | 3-29 |
| CHECKING AND LUBRICATING THE CABLES | 3-29 |
| LUBRICATING THE BRAKE LEVER | 3-30 |
| LUBRICATING THE CLUTCH LEVER..... | 3-30 |
| LUBRICATING THE PEDAL | 3-30 |
| CHECKING THE SIDESTAND..... | 3-30 |
| LUBRICATING THE SIDESTAND..... | 3-30 |
| | |
| ELECTRICAL SYSTEM..... | 3-31 |
| CHECKING AND CHARGING THE BATTERY | 3-31 |
| CHECKING THE FUSES | 3-31 |
| REPLACING THE HEADLIGHT BULB..... | 3-31 |

PERIODIC MAINTENANCE

EAM20133

PERIODIC MAINTENANCE

EAM30332

INTRODUCTION

This chapter includes all information necessary to perform recommended checks and adjustments. If followed, these preventive maintenance procedures will ensure more reliable vehicle operation, a longer service life and reduce the need for costly overhaul work. This information applies to vehicles already in service as well as to new vehicles that are being prepared for sale. All service technicians should be familiar with this entire chapter.

EAM30208

PERIODIC MAINTENANCE CHART FOR THE EMISSION CONTROL SYSTEM

TIP

- From 4200 mi (7000 km) or 9 months, repeat the maintenance intervals starting from 1800 mi (3000 km) or 3 months.
- Items marked with an asterisk should be performed by a Yamaha dealer as they require special tools, data and technical skills.

| No. | Item | Checks and maintenance jobs | Initial | Odometer readings | |
|-----|---------------------------|--|-----------------------------|-------------------------------|-------------------------------|
| | | | 600 mi (1000 km) or 1 month | 1800 mi (3000 km) or 3 months | 3000 mi (5000 km) or 6 months |
| 1 | * Fuel line | <ul style="list-style-type: none"> • Check fuel hoses for cracks or damage. • Replace if necessary. | √ | √ | √ |
| 2 | Spark plug | <ul style="list-style-type: none"> • Check condition. • Adjust gap and clean. | √ | √ | √ |
| 3 | * Valve clearance | <ul style="list-style-type: none"> • Check and adjust valve clearance when engine is cold. | √ | | √ |
| 4 | * Air filter element | <ul style="list-style-type: none"> • Clean with solvent and apply Yamaha foam air filter oil or other quality foam air filter oil. • Replace if necessary. | √ | √ | √ |
| 5 | * Breather system | <ul style="list-style-type: none"> • Check ventilation hose for cracks or damage and drain any deposits. | √ | √ | √ |
| 6 | * Fuel injection | <ul style="list-style-type: none"> • Adjust engine idling speed. | √ | √ | √ |
| 7 | Exhaust system | <ul style="list-style-type: none"> • Check for leakage. • Tighten if necessary. • Replace gasket(s) if necessary. | √ | √ | √ |
| 8 | Engine oil | <ul style="list-style-type: none"> • Change (warm engine before draining). | √ | √ | √ |
| 9 | Engine oil filter element | <ul style="list-style-type: none"> • Replace. | √ | √ | √ |
| 10 | Engine oil strainer | <ul style="list-style-type: none"> • Clean. | √ | √ | √ |

EAM30333

GENERAL MAINTENANCE AND LUBRICATION CHART

| No. | Item | Checks and maintenance jobs | Initial | Odometer readings | |
|-----|------------------|--|-----------------------------|-------------------------------|-------------------------------|
| | | | 600 mi (1000 km) or 1 month | 1800 mi (3000 km) or 3 months | 3000 mi (5000 km) or 6 months |
| 1 | Clutch | <ul style="list-style-type: none"> • Check operation. • Adjust or replace cable. | √ | √ | √ |
| 2 | * Cooling system | <ul style="list-style-type: none"> • Check hoses for cracks or damage. • Replace if necessary. • Replace with ethylene glycol anti-freeze coolant every 1 year. | √ | √ | √ |
| 3 | * Spark arrester | <ul style="list-style-type: none"> • Clean. | | | √ |

PERIODIC MAINTENANCE

| No. | Item | Checks and maintenance jobs | Initial | Odometer readings | |
|-----|-------------------------------------|---|-----------------------------|-------------------------------|-------------------------------|
| | | | 600 mi (1000 km) or 1 month | 1800 mi (3000 km) or 3 months | 3000 mi (5000 km) or 6 months |
| 4 | * Front brake | <ul style="list-style-type: none"> • Check operation, fluid level, and for fluid leakage. • Replace brake pads if necessary. | √ | √ | √ |
| | | <ul style="list-style-type: none"> • Replace brake fluid every 1 year. | Every 1 year | | |
| 5 | * Rear brake | <ul style="list-style-type: none"> • Check operation, fluid level, and for fluid leakage. • Replace brake pads if necessary. | √ | √ | √ |
| | | <ul style="list-style-type: none"> • Replace brake fluid every 1 year. | Every 1 year | | |
| 6 | * Brake hoses | <ul style="list-style-type: none"> • Check for cracks or damage. | | √ | √ |
| | | <ul style="list-style-type: none"> • Replace. | Every 4 years | | |
| 7 | * Wheels | <ul style="list-style-type: none"> • Check runout, spoke tightness and for damage. • Tighten spokes if necessary. | √ | √ | √ |
| 8 | * Tires | <ul style="list-style-type: none"> • Check tread depth and for damage. • Replace if necessary. • Check air pressure. • Correct if necessary. | √ | √ | √ |
| 9 | * Wheel bearings | <ul style="list-style-type: none"> • Check bearings for smooth operation. • Replace if necessary. | √ | √ | √ |
| 10 | * Swingarm pivot bearings | <ul style="list-style-type: none"> • Check bearing assemblies for looseness. • Moderately repack with lithium-soap-based grease. | √ | √ | √ |
| 11 | Drive chain | <ul style="list-style-type: none"> • Check chain slack/alignment and condition. • Adjust and lubricate chain with a special O-ring chain lubricant thoroughly. | Every ride | | |
| 12 | * Steering bearings | <ul style="list-style-type: none"> • Check bearing assemblies for looseness. • Moderately repack with lithium-soap-based grease every 1200 mi (2000 km) or 12 months (whichever comes first). | √ | √ | √ |
| 13 | Brake and clutch lever pivot shafts | <ul style="list-style-type: none"> • Apply lithium-soap-based grease (all-purpose grease) or silicone grease lightly. | √ | √ | √ |
| 14 | Brake pedal pivot shafts | <ul style="list-style-type: none"> • Apply lithium-soap-based grease (all-purpose grease) lightly. | √ | √ | √ |
| 15 | Sidestand pivot | <ul style="list-style-type: none"> • Check operation. • Apply lithium-soap-based grease (all-purpose grease) lightly. | √ | √ | √ |
| 16 | * Front fork | <ul style="list-style-type: none"> • Check operation and for oil leakage. • Replace if necessary. | | √ | √ |
| 17 | * Shock absorber assembly | <ul style="list-style-type: none"> • Check operation and for oil leakage. • Replace if necessary. | | √ | √ |
| 18 | * Rear suspension link pivots | <ul style="list-style-type: none"> • Apply molybdenum disulfide grease lightly. | | √ | √ |
| 19 | * Control cables | <ul style="list-style-type: none"> • Apply Yamaha chain and cable lube or engine oil 10W-30 thoroughly. | √ | √ | √ |
| 20 | * Throttle grip housing and cable | <ul style="list-style-type: none"> • Check operation and free play. • Adjust the throttle cable free play if necessary. • Lubricate the throttle grip housing and cable. | √ | √ | √ |
| 21 | * Chassis fasteners | <ul style="list-style-type: none"> • Check all chassis fitting and fasteners. • Correct if necessary. | √ | √ | √ |
| 22 | Battery | <ul style="list-style-type: none"> • Check terminal for looseness and corrosion. | | √ | √ |

TIP

- The air filter needs more frequent service if you are riding in unusually wet or dusty areas.
- Hydraulic brake service
 - After disassembling the brake master cylinders and calipers, always change the fluid. Regularly check the brake fluid levels and fill the reservoirs as required.
 - Every two years replace the internal components of the brake master cylinders and calipers, and

PERIODIC MAINTENANCE

change the brake fluid.

- Replace the brake hoses every four years and if cracked or damaged.

EAM30334

MAINTENANCE INTERVALS FOR COMPETITION USE

TIP

- The following schedule is intended as a general guide to maintenance and lubrication. Bear in mind that such factors as weather, terrain, geographical location, and individual usage will alter the required maintenance and lubrication intervals. If you are a doubt as to what intervals to follow in maintaining and lubricating your machine, consult your Yamaha dealer.
- Periodic inspection is essential in making full use of the machine performance. The service life of the parts varies substantially according to the environment in which the machine runs (e.g., rain, dirt, etc.). Therefore, earlier inspection is required by reference to the list below.
- Items marked with an asterisk should be performed by a Yamaha dealer as they require special tools, data and technical skills.

| No. | Item | Routine | After break-in | Every race | Every third race (or 500 km) | Every fifth race (or 1000 km) | As required |
|-----|---------------------|--|----------------|------------|------------------------------|-------------------------------|-------------|
| 1 | Engine oil | • Replace. | √ | | | √ | |
| 2 | * Valve | • Check the valve clearances. | √ | | √ | | |
| | | • Check the valve seats and the valve stems for wear. | | | | √ | |
| | | • Replace. | | | | | √ |
| 3 | * Valve spring | • Check the free length. | | | | √ | |
| | | • Replace. | | | | | √ |
| 4 | * Valve lifter | • Check for scratches and wear. | | | | √ | |
| | | • Replace. | | | | | √ |
| 5 | * Camshaft | • Inspect the camshaft surface. • Inspect the decompression system. | | | | √ | |
| | | • Replace. | | | | | √ |
| 6 | * Camshaft sprocket | • Check for wear on the teeth and for damage. | | | | √ | |
| | | • Replace. | | | | | √ |
| 7 | * Piston | • Inspect crack. • Inspect carbon deposits and eliminate them. | | | | √ | √ |
| | | • Clean. | | | | | √ |
| | | • Replace. (It is recommended that the piston pin and ring are also replaced at the same time.) | | | | | √ |
| 8 | * Piston ring | • Check the ring end gap. | | | | √ | |
| | | • Replace. | | | | √ | √ |
| 9 | * Piston pin | • Inspect. | | | | √ | |
| | | • Replace. | | | | | √ |
| 10 | * Cylinder head | • Inspect carbon deposits and eliminate them. • Change gasket. | | | | √ | |
| 11 | * Cylinder | • Inspect score marks. • Inspect wear. | | | | √ | |
| | | • Replace. | | | | | √ |

PERIODIC MAINTENANCE

| No. | Item | Routine | After break-in | Every race | Every third race (or 500 km) | Every fifth race (or 1000 km) | As required | |
|------|----------------------------------|---|----------------|------------------|------------------------------|-------------------------------|-------------|---|
| 12 * | Clutch | • Inspect housing, friction plate, clutch plate and spring. | √ | √ | | | | |
| | | • Replace. | | | | | √ | |
| 13 * | Transmission | • Inspect. | | | | | √ | |
| | | • Replace bearings. | | | | | √ | |
| 14 * | Shift fork, shift cam, guide bar | • Inspect wear. | | | | | √ | |
| 15 * | Generator rotor nut | • Retighten. | √ | | | √ | | |
| 16 * | Muffler | • Inspect and retighten. | √ | √ | | | | |
| | | • Clean. | | | | √ | | |
| | | • Replace. | | | | | √ | |
| 17 * | Crank | • Inspect and clean. | | | | √ | √ | |
| 18 * | Throttle body | • Inspect. | | | | | √ | |
| 19 | Spark plug | • Inspect and clean. | √ | | √ | | | |
| | | • Replace. | | | | | √ | |
| 20 | Drive chain | • Lubricate, slack, alignment. | √ | √ | | | | |
| | | • Replace. | | | | | √ | |
| 21 * | Cooling system | • Check coolant level and leakage. | √ | √ | | | | |
| | | • Check radiator cap operation. | | | | | √ | |
| | | • Replace coolant. | | Every two years | | | | √ |
| | | • Inspect hoses. | | √ | | | | |
| 22 | Outside nuts and bolts | • Retighten. | √ | √ | | | | |
| 23 | Air filter | • Clean and lubricate. | √ | √ | | | | |
| | | • Replace. | | | | | √ | |
| 24 | Oil filter | • Replace. | √ | | | √ | | |
| 25 * | Engine guard | • Replace. | | | | | √ | |
| 26 * | Frame | • Clean and inspect. | √ | √ | | | | |
| 27 * | Fuel tank, fuel pump | • Clean and inspect. | √ | | √ | | | |
| 28 * | Fuel hose | • Inspect. | | | | | √ | |
| | | • Replace. | | Every four years | | | | √ |
| 29 * | Brake(s) | • Adjust lever position and pedal position. | √ | √ | | | | |
| | | • Lubricate pivot point. | √ | √ | | | | |
| | | • Check brake disc surface. | √ | √ | | | | |
| | | • Check fluid level and leakage. | √ | √ | | | | |
| | | • Retighten brake disc bolts, caliper bolts, master cylinder bolts and union bolts. | √ | √ | | | | |
| | | • Replace pads. | | | | | √ | |
| | | • Replace brake fluid. | | Every one year | | | | √ |
| 30 * | Front fork(s) | • Inspect and adjust. | √ | √ | | | | |
| | | • Replace oil. | √ | | | √ | | |
| | | • Replace oil seal. | | | | | √ | |

PERIODIC MAINTENANCE

| No. | Item | Routine | After break-in | Every race | Every third race (or 500 km) | Every fifth race (or 1000 km) | As required |
|-----|-------------------------------------|---|----------------|------------|------------------------------|-------------------------------|-------------|
| 31 | * Front fork oil seal and dust seal | • Clean and lubricate. | √ | √ | | | |
| 32 | Protector guide | • Replace. | | | | | √ |
| 33 | * Rear shock absorber | • Inspect and adjust. | √ | √ | | | |
| | | • Lubricate. (After rain ride) | | | √ | | √ |
| | | • Retighten. | √ | √ | | | |
| 34 | * Drive chain guard and roller | • Inspect. | √ | √ | | | |
| 35 | * Drive chain stopper | • Inspect. | | | | | √ |
| 36 | * Swingarm | • Inspect, lube and retighten. | √ | √ | | | |
| 37 | * Relay arm, connecting rod | • Inspect, lube and retighten. | √ | √ | | | |
| 38 | Sidestand | • Lubricate. | | | | | √ |
| 39 | * Steering head | • Inspect free play and retighten. | √ | √ | | | |
| | | • Clean and lubricate. | | | | √ | |
| | | • Replace bearings. | | | | | √ |
| 40 | * Tire, wheels | • Inspect air pressure, wheel run-out, tire wear and spoke looseness. | √ | √ | | | |
| | | • Retighten sprocket bolt. | √ | √ | | | |
| | | • Inspect bearings. | | | √ | | |
| | | • Replace bearings. | | | | | √ |
| | | • Lubricate. | | | √ | | |
| 41 | Throttle, control cable | • Check routing and connection. | √ | √ | | | |
| | | • Lubricate. | √ | √ | | | |

PRE-OPERATION INSPECTION AND MAINTENANCE

EAM20134

PRE-OPERATION INSPECTION AND MAINTENANCE

Before riding for break-in operation, practice or a race, make sure the machine is in good operating condition.

Before using this machine, check the following points.

EAM30209

GENERAL INSPECTION AND MAINTENANCE

| Item | Inspect | Page |
|-------------------------------------|--|---|
| Coolant | Check that coolant is filled up to the radiator cap. Check the cooling system for leakage. | 3-16, 3-17, 3-17 |
| Fuel | Check that a fresh gasoline is filled in the fuel tank. Check the fuel line for leakage. | 1-22 |
| Engine oil | Check that the oil level is correct. Check the crankcase and oil line for leakage. | 3-10, 3-10 |
| Gear shifter and clutch | Check that gears can be shifted correctly in order and that the clutch operates smoothly. | 3-12 |
| Throttle grip/Housing | Check that the throttle grip operation and free play are correctly adjusted. Lubricate the throttle grip and housing, if necessary. | 3-8, 3-29 |
| Brakes | Check the play of front brake and effect of front and rear brake. | 3-19, 3-19, 3-19, 3-20, 3-20, 3-20, 3-20, 3-21 |
| Drive chain | Check drive chain slack and alignment. Check that the drive chain is lubricated properly. | 3-22, 4-32, 4-32, 4-33, 4-33, 4-33 |
| Wheels | Check for excessive wear and tire pressure. Check for loose spokes and have no excessive play. | 3-28, 3-29, 3-29 |
| Steering | Check that the handlebar can be turned smoothly and have no excessive play. | 3-23 |
| Front forks and rear shock absorber | Check that they operate smoothly and there is no oil leakage. | 3-24, 3-25, 3-26, 3-26, 3-28 |
| Cables (wires) | Check that the clutch and throttle cables move smoothly. Check that they are not caught when the handlebars are turned or when the front forks travel up and down. | — |
| Exhaust pipe | Check that the exhaust pipe is tightly mounted and has no cracks. | 3-15 |
| Rear wheel sprocket | Check that the rear wheel sprocket tightening bolt is not loose. | 4-5, 4-5, 4-5 |
| Lubrication | Check for smooth operation. Lubricate if necessary. | 3-29, 3-30, 3-30, 3-30 |
| Bolts and nuts | Check the chassis and engine for loose bolts and nuts. | 1-26 |
| Lead connectors | Check that the stator coil assembly, ECU and ignition coil are connected tightly. | — |
| Settings | Is the machine set suitably for the condition of the racing course and weather or by taking into account the results of test runs before racing? Are inspection and maintenance completely done? | 9-1, 9-1, 9-1, 9-2, 9-2, 9-3, 9-3, 9-4, 9-4, 9-6, 9-7 |

TIP

Perform usual maintenance enough so that, in the race course, a confirmation of that and simple setting adjustments may only be left, in order to get enough time to use effectively.

EAM20135

ENGINE

EAM30226

ADJUSTING THE VALVE CLEARANCE

TIP

- This section is intended for those who have basic knowledge and skill concerning the servicing of Yamaha motorcycles (e.g., Yamaha dealers, service engineers, etc.). Those who have little knowledge and skill concerning servicing are requested not to undertake inspection, adjustment, disassembly, or reassembly only by reference to this manual. It may lead to servicing trouble and mechanical damage.
- Make sure that the valve clearance is checked or adjusted while the engine is cold (at room temperature).
- While the valve clearance is checked or adjusted, make sure that the piston is positioned in the top dead center (TDC).

1. Remove:

- Seat
- Side cover (left/right)
- Air scoop (left/right)
- Fuel tank
Refer to "FUEL TANK" on page 6-1.
- ECU (Engine Control Unit)

2. Remove:

- Spark plug
- Cylinder head cover

3. Remove:

- Timing mark accessing screw "1"
- Crankshaft end accessing screw "2"
- O-ring

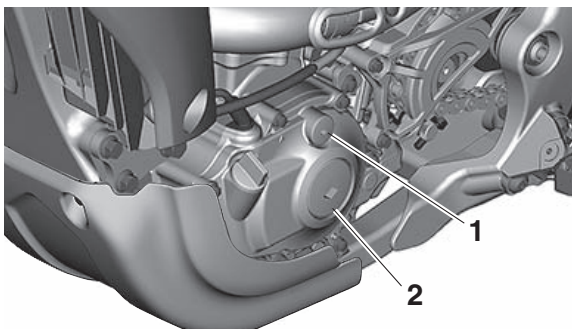

4. Check:

- Valve clearance
Out of specification → Regulate.



Valve clearance (cold)

Intake

0.10–0.17 mm (0.0039–0.0067 in)

Exhaust

0.15–0.22 mm (0.0059–0.0087 in)

- Turn the crankshaft counterclockwise with a wrench.
- Align the top dead center (TDC) mark "a" on the generator rotor with the alignment mark "b" on the crankcase cover.

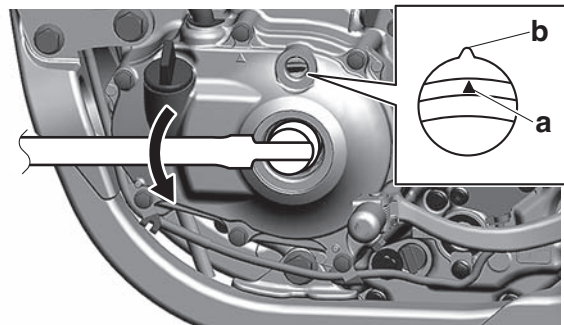

TIP

Check that the alignment marks "c" on the camshaft sprockets are aligned with the edge of the camshaft cap surfaces "d".

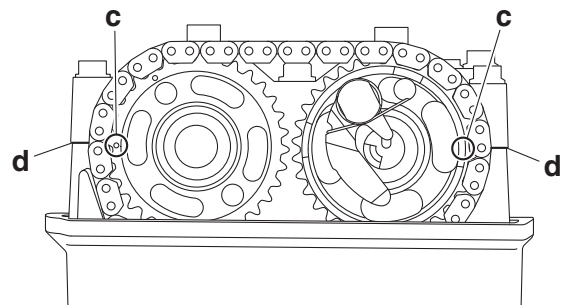

- Measure the valve clearance using a thickness gauge "1".



Thickness gauge

90890-03268

Feeler gauge set

YU-26900-9

TIP

Record the measured reading if the clearance is incorrect.

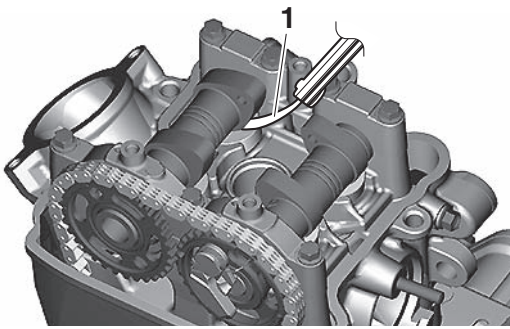

EAM30412

CHECKING THE ENGINE IDLING SPEED

TIP

- Because the air pressure is lower at high altitudes, the air-fuel mixture will become richer. If the idling speed is low, turn the idle screw clockwise to increase the speed before the adjustment.
- Before adjusting the engine idling speed, make sure that the air filter element is not clogged, the engine compression is proper, and the throttle grip free play is proper.
- Adjust the engine idling speed with the starter knob pulled in completely.

1. Start the engine, and warm this up until the oil has reached the specified temperature.
2. Measure the coolant temperature using the Yamaha diagnostic tool.



Yamaha diagnostic tool USB
90890-03267
Yamaha diagnostic tool (A/I)
90890-03264
FI diagnostic tool sub-lead
90890-03212
FI diagnostic tool sub-lead
YU-03212
OBD/ GST Leadwire kit
90890-03249



Coolant temperature
70–90 °C (158–194 °F)

3. Install:
 - Digital tachometer



Digital tachometer
90890-06760
Digital tachometer
YU-39951-B

TIP

Get the high tension cord “1” of the ignition coil pinched in the detector “a” of the digital tachom-

eter.

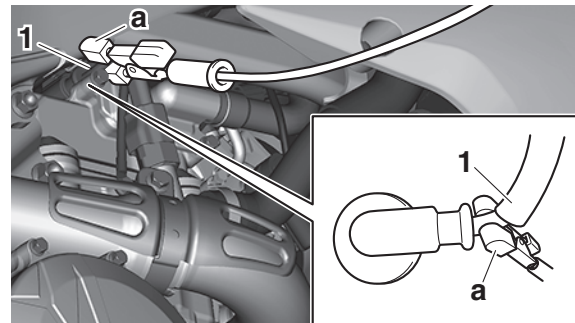

4. Measure:
 - Engine idling speed
 Out of specification → Regulate.



Engine idling speed
1900–2100 r/min

5. Adjust:
 - Engine idling speed
 - a. Turn the idle screw “1” to make an adjustment.

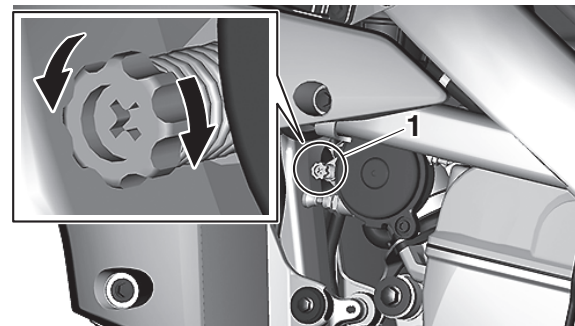

EAM30475

CHECKING THE THROTTLE GRIP

TIP

Prior to adjusting throttle grip free play, the engine idling speed should be adjusted.

1. Check:
 - Throttle grip free play “a”
 Out of specification → Regulate.



Throttle grip free play
3.0–6.0 mm (0.12–0.24 in)

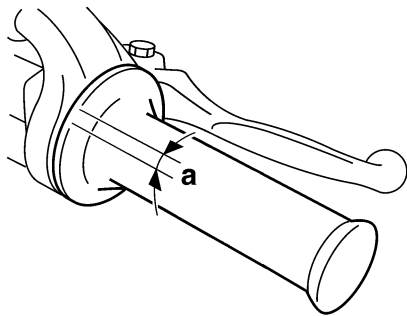

2. Adjust:

- Throttle grip free play
 - a. Loosen the locknut "1".
 - b. Turn the adjuster "2" until the specified throttle grip free play is obtained.
 - c. Tighten the locknut.

EWA18470

WARNING

After adjusting the throttle grip free play, start the engine and turn the handlebar to the right and to the left to ensure that this does not cause the engine idling speed to change.

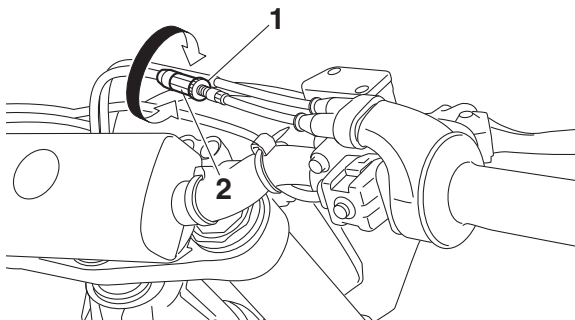

EAM30254

CHECKING THE SPARK PLUG

1. Remove:

- Seat
- Air scoop (left/right)
- Fuel tank "1"

Refer to "FUEL TANK" on page 6-1.

ECA24400

NOTICE

Do not use too much force to pull the hose.

TIP

Remove the fuel tank, turn this 180° clockwise, and put it in the frame "2" as shown.

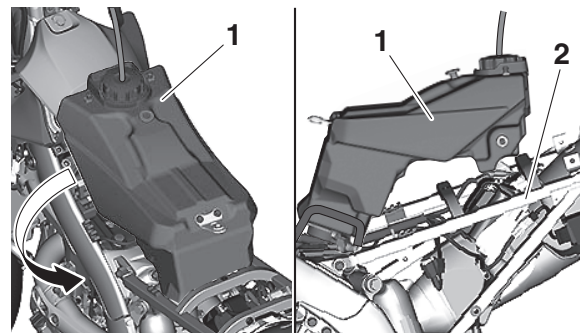

2. Remove:

- Spark plug cap
- Spark plug

ECA24410

NOTICE

In order not to allow the dirt accumulated around the spark plug to drop from the spark plug hole into the cylinder, clean it before removing the spark plug.

3. Check:

- Spark plug type
Wrong type → Replace.



Manufacturer/model
NGK/LMAR8G

4. Check:

- Electrode
Damage/wear → Replace the spark plug.
- Insulator
Abnormal color → Replace the spark plug.
Normal color is medium-to-light tan.

5. Clean:

- Spark plug
(with a spark plug cleaner or a wire brush)

6. Measure:

- Spark plug gap "a"
Out of specification → Adjust the spark plug gap.



Spark plug gap
0.7–0.8 mm (0.028–0.031 in)

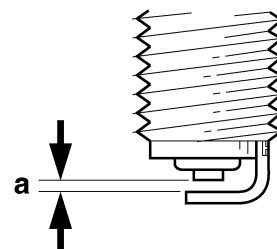

7. Install:
- Spark plug

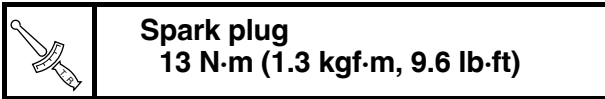

TIP
Before installing the spark plug, clean the spark plug and gasket surface.

8. Install:
- Spark plug cap
 - Fuel tank
 - Air scoop (left/right)
 - Seat
 - Side cover (left/right)
- Refer to “GENERAL CHASSIS” on page 4-1.

EAM30224

CHECKING THE ENGINE OIL LEVEL

1. Stand the vehicle upright on a level surface.
2. Start the engine, warm this up for 2–3 minutes, and then stop the engine and wait about 1 minute.
3. Check:

- Oil level

Make sure that the engine oil level is above the minimum level mark “a” shown for the oil level check window “1”, and that the engine oil does not come out by removing the oil check bolt “2”.

The minimum level mark “a” or below → Add the engine oil until its level exceeds the minimum level mark “a”.

Engine oil coming out of the oil check bolt → Drain it until its last drop is out.

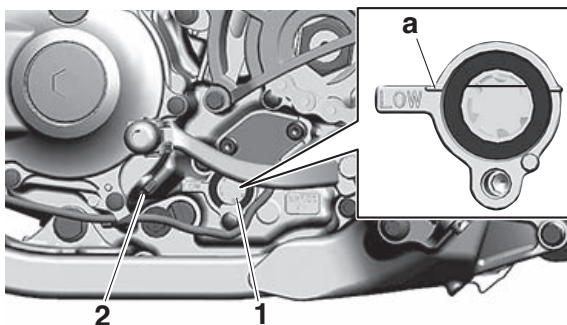

ECA24290

NOTICE

- Since engine oil also lubricates the clutch, the wrong oil types or additives could cause clutch slippage. Therefore, do not add any chemical additives.
- Do not allow foreign material to enter the crankcase.



Recommended brand
YAMALUBE
SAE viscosity grades
10W-40, 10W-50, 15W-40, 20W-40 or 20W-50
Recommended engine oil grade
API service SG type or higher,
JASO standard MA

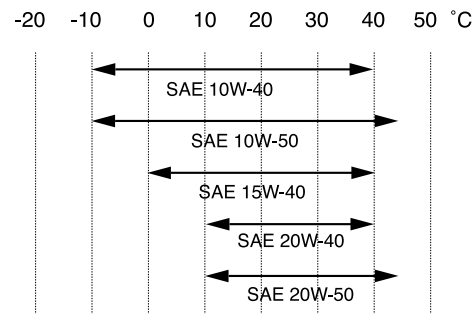

EAM30225

CHANGING THE ENGINE OIL

Stand the vehicle upright on a level surface.

1. Start the engine, warm this up for several minutes, and then stop the engine and wait about 5 minutes.

TIP

This model is equipped with an engine auto-stop system. The engine stops automatically if left idling for 7 minutes. If the engine stops, push the start switch to restart the engine.

2. Place an oil pan under the drain bolt.
3. Remove:
 - Engine guard “1”
 - Oil filler cap “2”
 - Drain bolt (with gasket) “3”

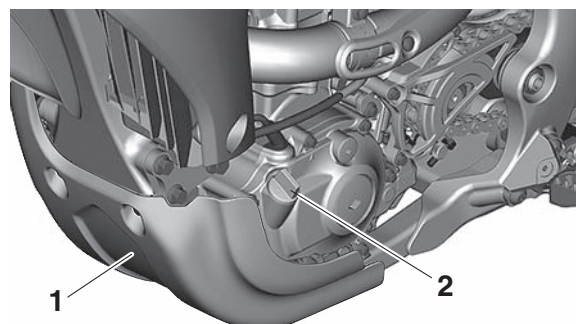

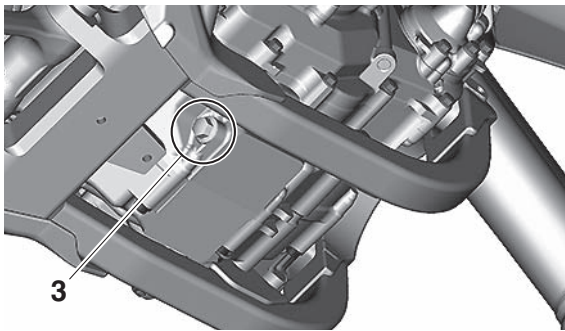

4. If the oil filter element is also to be replaced, perform the following procedure.
 - a. Remove the oil filter element cover “1” and oil filter element “2”.
 - b. Replace the new O-ring “3”.

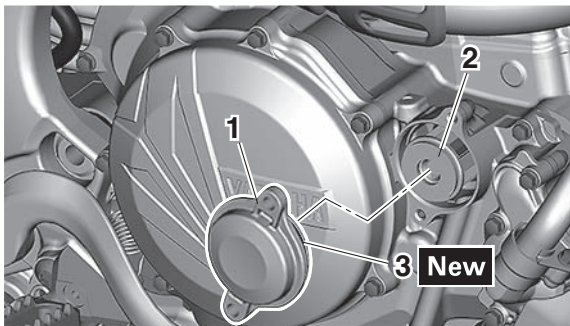

- c. Install the new oil filter element and the oil filter element cover.



Oil filter element cover bolt
10 N·m (1.0 kgf·m, 7.4 lb-ft)

5. To check the oil strainer, perform the following procedure.
 - a. Remove the oil strainer “1”.
 - b. Check the oil strainer.
 Damage → Replace.
 Clogging due to dirt → Wash with kerosene.
 - c. Replace the new O-ring “2”.

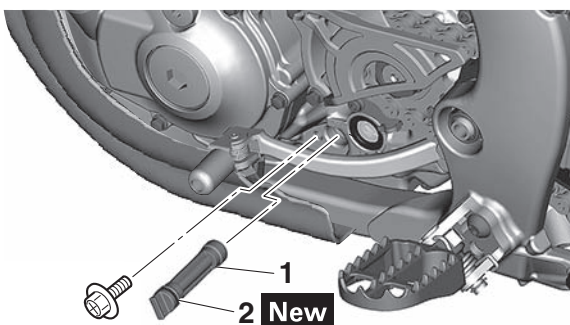

- d. Install the oil strainer.



Oil strainer bolt
10 N·m (1.0 kgf·m, 7.4 lb-ft)

6. Install:
 - Gasket **New**
 - Drain bolt



Drain bolt
20 N·m (2.0 kgf·m, 15 lb-ft)

7. Pour the specified amount of engine oil into the oil filler cap hole.



Engine oil quantity
Oil change
0.63 L (0.67 US qt, 0.55 Imp.qt)
With oil filter removal
0.65 L (0.69 US qt, 0.57 Imp.qt)
Quantity (disassembled)
0.90 L (0.95 US qt, 0.79 Imp.qt)

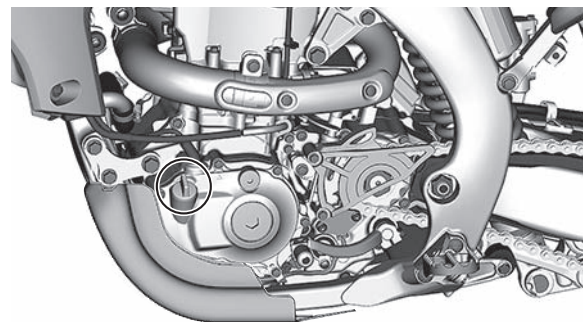

8. Install:
 - Oil filler cap
9. Check:
 - Oil level
 Refer to “CHECKING THE ENGINE OIL LEVEL” on page 3-10.
10. Check:
 - Engine oil pressure
 - a. Start the engine.

EWA19130

⚠ WARNING

Always keep the engine idling speed during the checkup without increasing the engine speed.

- b. Look at the oil level check window “1”, and then make sure that the engine oil flows and that the engine oil level decreases.

TIP

Check the engine oil level while the engine is at idling speed.

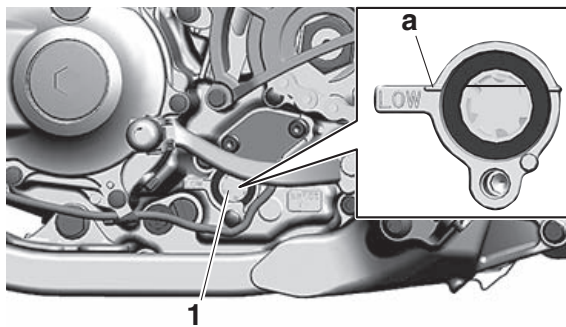

a. Minimum level mark

ECA26740

NOTICE

If the engine oil level does not decrease after the engine has been started, immediately turn the engine off. Otherwise, the engine could seize.

- c. If the engine oil level does not decrease at the specified level mark, check the engine oil system for leaks, and the engine oil passages and oil pump for damage.
- d. Check the oil pressure again.

EAM30216

ADJUSTING THE CLUTCH LEVER FREE PLAY

1. Check:

- Clutch lever free play "a"
Out of specification → Regulate.



Clutch lever free play
7.0–12.0 mm (0.28–0.47 in)

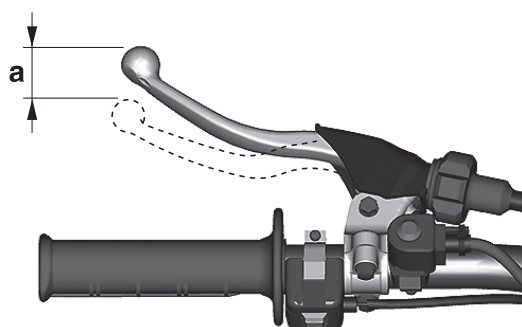

2. Adjust:

- Clutch lever free play
Handlebar side
 - a. Turn the adjuster "1" until the specified clutch lever free play is obtained.

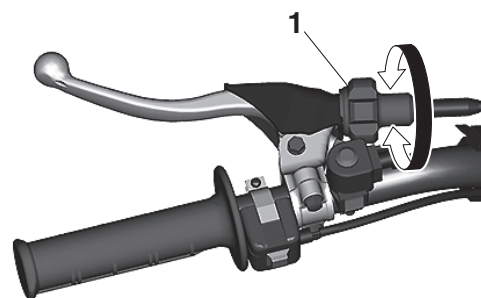

TIP

If the clutch lever free play cannot be obtained on the handlebar side, use the adjuster on the clutch cable side.

Clutch cable side

- a. Slide the clutch cable cover.
- b. Loosen the locknut "1".
- c. Turn the adjuster "2" until the specified clutch lever free play is obtained.
- d. Tighten the locknut "1".



Clutch cable locknut
4.3 N·m (0.43 kgf·m, 3.2 lb·ft)

- e. Return the clutch cable cover to its original position.

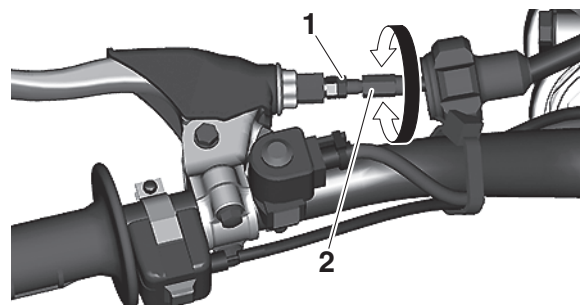

EAM30219

CLEANING THE AIR FILTER ELEMENT

1. Remove:

- Fuel tank cap cover "1"
Refer to "FUEL TANK CAP" on page 1-14.
- Air filter case cover "2"

TIP

- Loosen the quick fastener screw "3" and remove the air filter case cover.
- Remove the two ribs "a" located on the left and right sides of the projections "b" on the air scoop, and slide the air filter case cover toward the front of the vehicle to remove it.

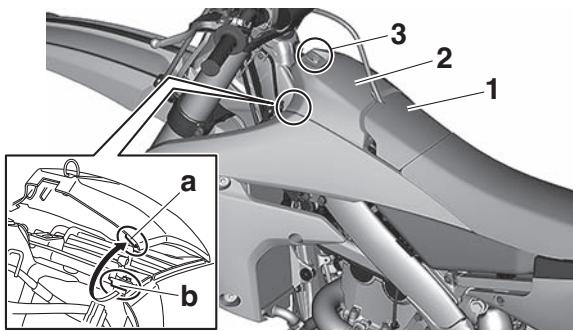

2. Turn the plates "1" in direction "a".

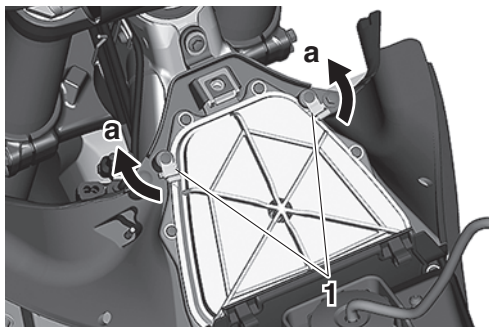

3. Remove:

- Air filter guide "1"
- Air filter element "2" (from the air filter guide)
- Guide "3" (from the air filter element)
- Seal "4" (from the air filter element)

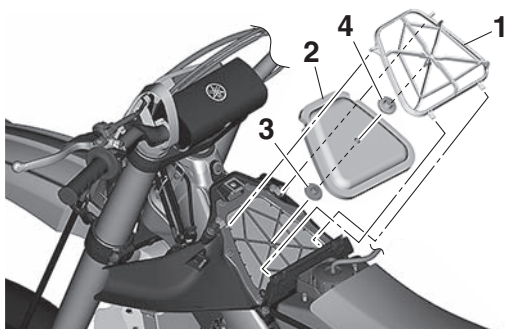

4. Wash:

- Air filter element
 - a. After washing the element with air filter cleaner or kerosene, squeeze and dry it completely.

EWA19110

WARNING

Do not use gasoline or organic (acid/alkaline) volatile oil for washing.

ECA24280

NOTICE

Do not twist the element when squeezing the element.

5. Check:

- Air filter element

Damage → Replace.

6. Apply:

- Yamaha foam air filter oil or other quality foam air filter oil
 - a. Put the air filter element into a plastic bag and drip the filter oil into the bag.
 - b. With the element inside the bag, rub it thoroughly so that the element is evenly permeated with the oil.
 - c. Wrap the element in a clean cloth, rub the element gently, and wipe off any excess oil.

TIP

- The element should be permeated with oil so that it is wet but not dripping.
- When replacing the element, permeate the element in oil by using the same procedure as when cleaning.

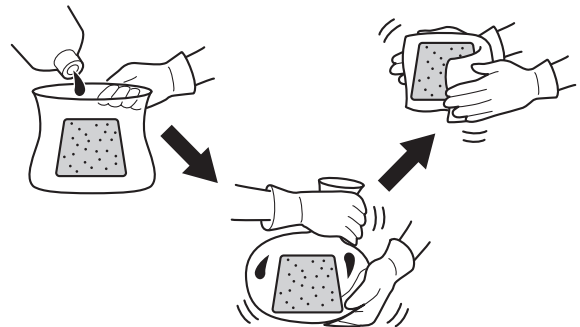

7. Install:

- Seal "1" (to the air filter element)
- Guide "2" (to the air filter element)
- Air filter element "3" (to the air filter guide)
- Air filter guide "4"

TIP

- Apply lithium-soap-based grease on the entire seal lips when installing the air filter guide.
- Make sure that the two projections "a" at the rear side of the vehicle on the air filter guide are securely fitted into the two slots "b" in the air filter case.
- Check that the air filter element is turned up between the air filter guide and air filter case and that there is no gap.
Gap → Reinstall.

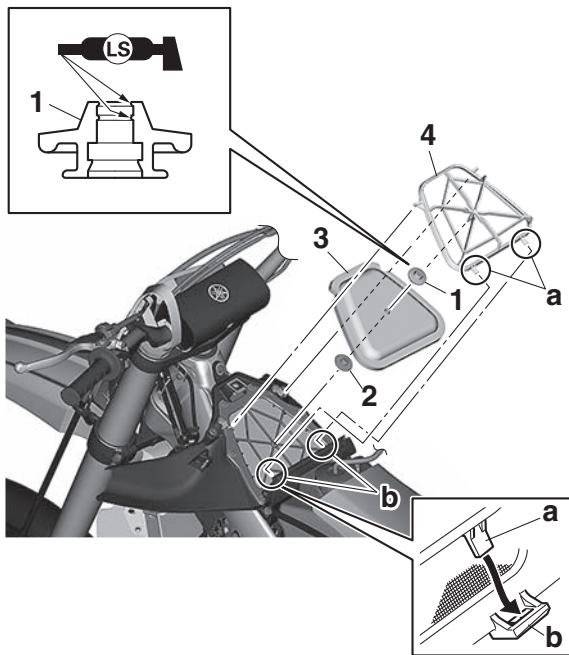

8. Turn the plates "1" to the original position.

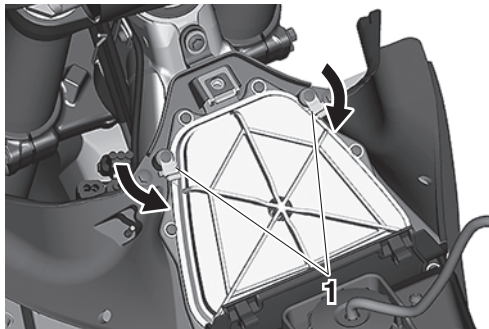

9. Install:

- Air filter case cover "1"
- Fuel tank breather hose (to the air filter case cover)

TIP

- Make sure that the two slots "a" at the rear side of the vehicle in the air filter case cover are securely fitted into the two edges "b" on the air filter case.
- Be sure to carefully align the two ribs "c" located on the left and right sides of the air filter case cover with the projections "d" on the air scoop, and then install the air filter case cover.

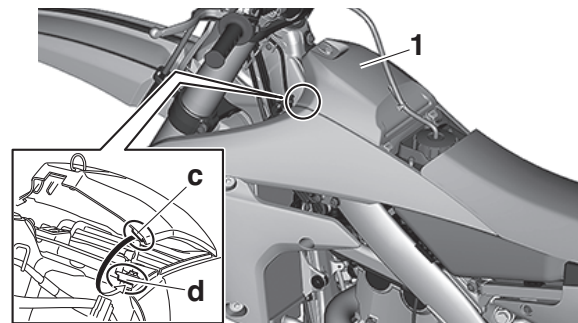
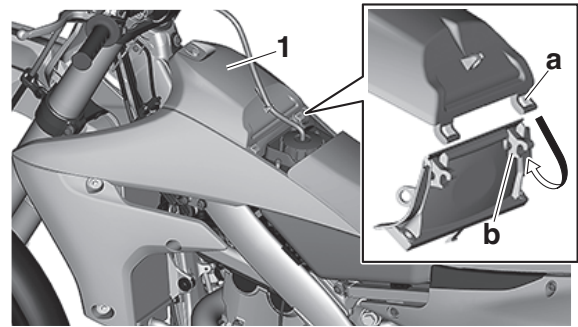

10. Install:

- Fuel tank cap cover

EAM30335

CHECKING THE THROTTLE BODY JOINT

1. Check:

- Throttle body joint "1"
Crack/damage → Replace.

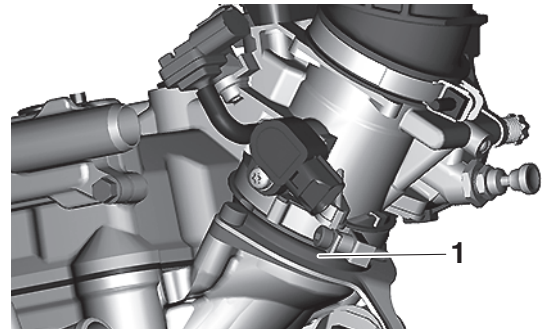

EAM30222

CHECKING THE FUEL LINE

1. Remove:

- Seat
- Side cover (left/right)
- Air scoop (left/right)
- Fuel tank

Refer to "FUEL TANK" on page 6-1.

2. Check:

- Fuel hose "1"
Crack/damage → Replace.
Loose connection → Connect properly.

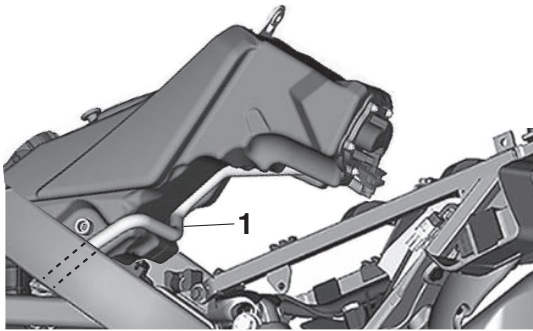

3. Install:
 - Fuel tank
Refer to "FUEL TANK" on page 6-1.
 - Air scoop (left/right)
 - Seat
 - Side cover (left/right)
Refer to "GENERAL CHASSIS" on page 4-1.

EAM30476

CHECKING THE CYLINDER HEAD BREATHER HOSE

1. Check:
 - Breather hose "1"
Crack/damage → Replace.
Loose connection → Connect properly.

ECA14920

NOTICE

Make sure the cylinder head breather hose is routed correctly.

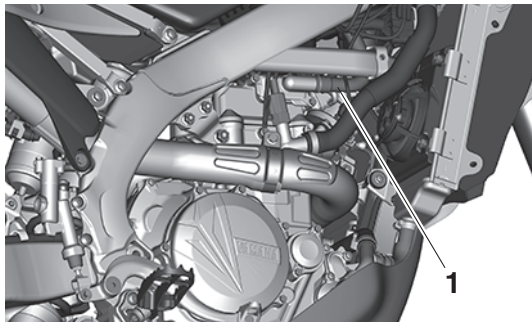

EAM30221

CHECKING THE EXHAUST SYSTEM

EWA19350

WARNING

- Be sure the exhaust pipe and muffler are cool before cleaning the spark arrester.
- Do not start the engine when cleaning the exhaust system.

1. Remove:
 - Exhaust pipe 1
 - Exhaust pipe 2
Refer to "EXHAUST SYSTEM" on page 5-1.

2. Remove:
 - Exhaust pipe protector
3. Check:
 - Exhaust pipe 1
 - Exhaust pipe 2
 - Silencer
Crack/damage → Replace.
4. Check:
 - Spark arrester
Carbon deposits → clean
5. Clean:
 - Spark arrester
 - a. Remove the silencer cap screws "1".

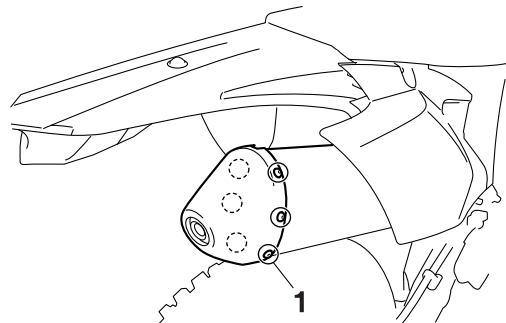

- b. Remove the spark arrester bolts "2".

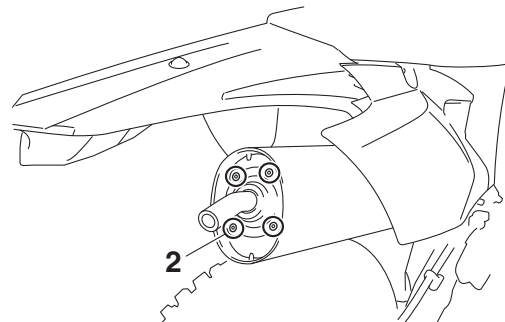

- c. Remove the tail pipe "3", tail pipe gasket "4" and spark arrester "5".

TIP

Pull the spark arrester out of the muffler.

- d. Remove the spark arrester gasket "6".

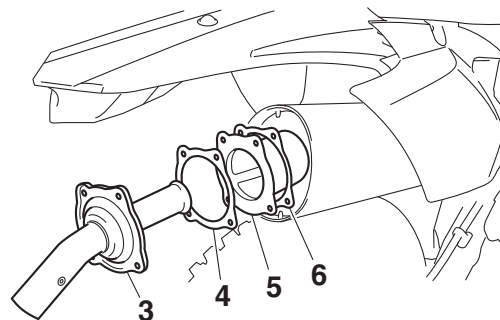

- e. Clean the spark arrester.

TIP

Tap the spark arrester lightly, then use a wire brush to remove any carbon deposits.

- f. Install the spark arrester gasket (new gasket) and spark arrester.

TIP

Insert the spark arrester into the muffler and align the bolt holes.

- g. Install the tail pipe gasket (new gasket) and spark arrester bolts.

| | |
|---|--|
|  | Spark arrester bolt 9 N·m (0.9 kgf·m, 6.6 lb·ft) |
|---|--|

- h. Install the silencer cap.

| | |
|---|---|
|  | Silencer cap screw 5 N·m (0.5 kgf·m, 3.7 lb·ft) |
|---|---|

TIP

First tighten the two screws “a” located horizontally apart, and then tighten the others.

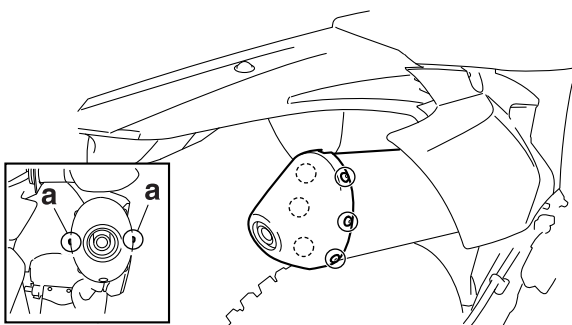

6. Check:

- Gasket “1”
Damage → Replace.

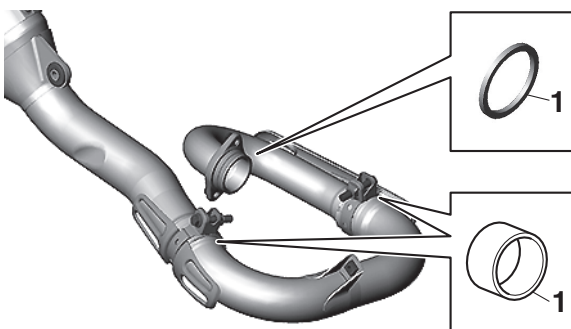

7. Check:

- Tightening torques



- Exhaust pipe nut “1”**
10 N·m (1.0 kgf·m, 7.4 lb·ft)
- Exhaust pipe clamp bolt “2”**
12 N·m (1.2 kgf·m, 8.9 lb·ft)
- Exhaust pipe clamp bolt “3”**
12 N·m (1.2 kgf·m, 8.9 lb·ft)
- Silencer bolt (rear) “4”**
30 N·m (3.0 kgf·m, 22 lb·ft)

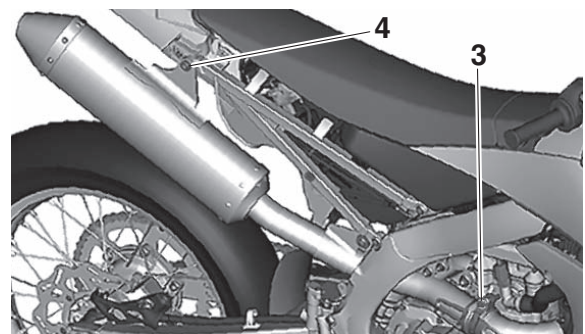
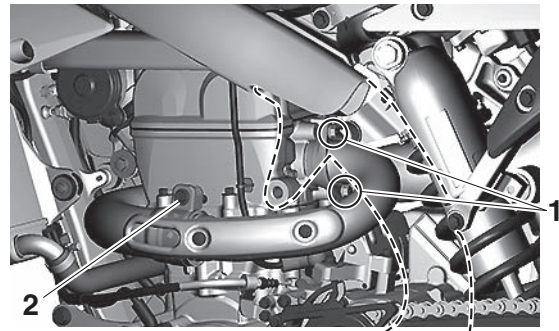

8. Install:

- Exhaust pipe protector



- Exhaust pipe protector screw**
10 N·m (1.0 kgf·m, 7.4 lb·ft)
LOCTITE®

EAM30210

CHECKING THE COOLANT LEVEL

EWA13030

⚠ WARNING

A hot radiator is under pressure. Therefore, do not remove the radiator cap when the engine is hot. Scalding hot fluid and steam may be blown out, which could cause serious injury. When the engine has cooled, open the radiator cap as follows:

Place a thick rag or a towel over the radiator cap and slowly turn the radiator cap counterclockwise toward the detent to allow any residual pressure to escape. When the hissing sound has stopped, press down on the radiator cap and turn it counterclockwise to remove.

1. Stand the vehicle upright on a level surface.
2. Remove:
 - Radiator cap "1"

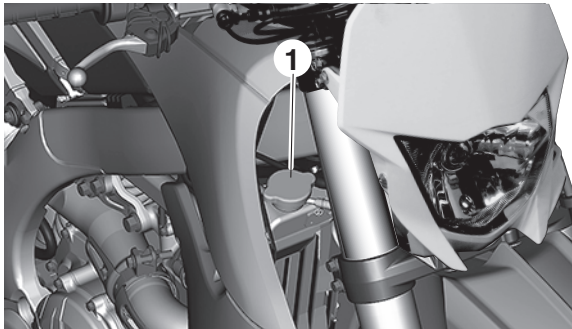

3. Check:
 - Coolant level
Maximum level "a" or below → Add coolant up to the maximum level.

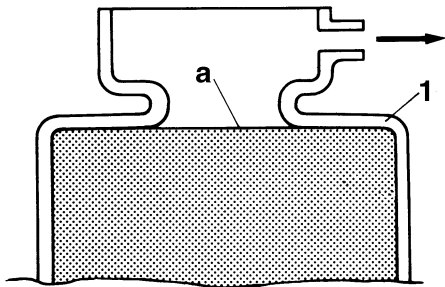

1. Radiator

ECA24260

NOTICE

- Adding water instead of coolant lowers the antifreeze content. If, therefore, water is used instead of coolant, check, and if necessary, adjust the antifreeze concentration.
- Use only distilled water. However, if distilled water is not available, soft water may be used.

4. Start the engine, warm this up for several minutes, and then stop it.
5. Check:
 - Coolant level

TIP

Before checking the coolant level, wait a few minutes until the coolant has settled.

EAM30211

CHECKING THE COOLING SYSTEM

1. Remove:
 - Seat
 - Side cover (left/right)
 - Air scoop (left/right)

2. Check:
 - Radiator
 - Radiator hose
Crack/damage → Replace.
3. Install:
 - Air scoop (left/right)
 - Seat
 - Side cover (left/right)

Refer to "GENERAL CHASSIS" on page 4-1.

EAM30212

CHANGING THE COOLANT

EWA13030

WARNING

A hot radiator is under pressure. Therefore, do not remove the radiator cap when the engine is hot. Scalding hot fluid and steam may be blown out, which could cause serious injury. When the engine has cooled, open the radiator cap as follows:

Place a thick rag or a towel over the radiator cap and slowly turn the radiator cap counterclockwise toward the detent to allow any residual pressure to escape. When the hissing sound has stopped, press down on the radiator cap and turn it counterclockwise to remove.

1. Place a container under the engine.
2. Remove:
 - Coolant drain bolt "1"

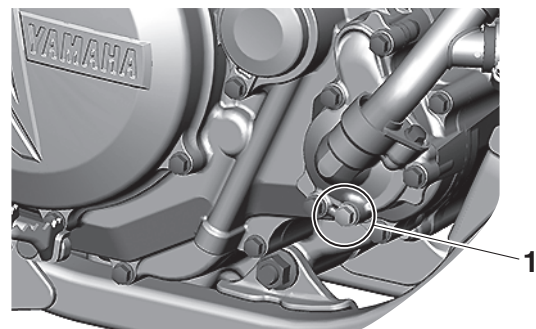

3. Remove:
 - Radiator cap
Slowly loosen the radiator cap to drain coolant.

TIP

When the radiator cap is loosened, coolant will gush out transversely; therefore, bring the container near to the outlet.

4. Thoroughly flush the cooling system with clean tap water.
5. Install:
 - Copper washer **New**
 - Coolant drain bolt



Coolant drain bolt
10 N·m (1.0 kgf·m, 7.4 lb·ft)

6. Pour coolant.



Recommended coolant
High quality ethylene glycol
anti-freeze containing anti-cor-
rosion for aluminum engine
Radiator (including all routes)
1.03 L (1.09 US qt, 0.91 Imp.qt)
Coolant mixing ratio
1:1 (Coolant:Water)

EWA13040

WARNING

- If coolant splashes in your eyes, thoroughly wash them with water and consult a doctor.
- If coolant splashes on your clothes, quickly wash it away with water and then with soap and water.
- If coolant is swallowed, induce vomiting and get immediate medical attention.

ECA13481

NOTICE

- Adding water instead of coolant lowers the antifreeze content of the coolant. If water is used instead of coolant, check, and if necessary, correct the antifreeze concentration of the coolant.
- Use only distilled water. However, if distilled water is not available, soft water may be used.
- If coolant comes into contact with painted surfaces, immediately wash them with water.
- Do not mix different types of antifreeze.

7. Install:

- Radiator cap

8. Start the engine, warm this up for several minutes, stop it, and then wait for it to cool down.

9. Check:

- Coolant level
Refer to "CHECKING THE COOLANT LEVEL" on page 3-16.

EAM20136

CHASSIS

EAM30479

ADJUSTING THE FRONT DISC BRAKE

TIP

There should be no free play at the brake lever end.

1. Check:
 - Brake lever position "a"

| | |
|---|---------------------------------|
|  | Brake lever position |
| | 100 mm (3.94 in) |
| | Extent of adjustment |
| | 86–105 mm (3.39–4.13 in) |

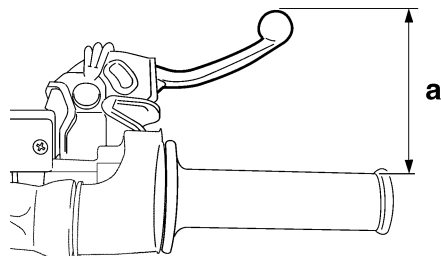

2. Remove:
 - Brake lever cover
3. Adjust:
 - Brake lever position
 - a. Loosen the locknut "1".
 - b. Turn the adjusting bolt "2" until the specified brake lever position is obtained.

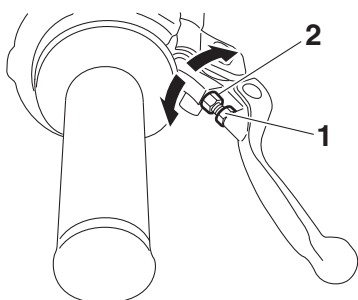

c. Tighten the locknut.

| | |
|---|-------------------------------------|
|  | Locknut |
| | 5 N·m (0.5 kgf·m, 3.7 lb·ft) |

EWA13050

WARNING

A soft or spongy feeling in the brake lever can indicate the presence of air in the brake system. Before the vehicle is operated, the air must be removed by bleeding the brake

system. Air in the brake system will considerably reduce braking performance.

ECA13490

NOTICE

After adjusting the brake lever position, make sure there is no brake drag.

4. Install:
 - Brake lever cover

EAM30480

ADJUSTING THE REAR DISC BRAKE

1. Adjust:
 - Brake pedal position
 - a. Loosen the locknut "1".
 - b. Turn the adjusting bolt "2" until the brake pedal is in the correct position.

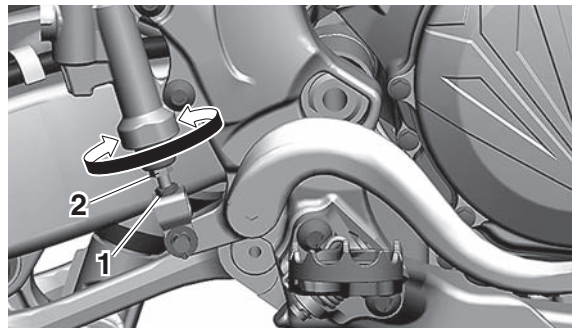

c. Tighten the locknut.

| | |
|---|-------------------------------------|
|  | Locknut |
| | 6 N·m (0.6 kgf·m, 4.4 lb·ft) |

EWA19150

WARNING

A soft or spongy feeling in the brake pedal can indicate the presence of air in the brake system. Before running, bleed the brake system. Air in the brake system will cause braking performance to be reduced.

ECA13510

NOTICE

After adjusting the brake pedal position, make sure there is no brake drag.

EAM30234

CHECKING THE BRAKE FLUID LEVEL

1. Stand the vehicle upright on a level surface.

TIP

In order to ensure a correct reading of the brake fluid level, make sure that the top of the brake fluid reservoir is horizontal.

2. Check:
 - Brake fluid level

The minimum level mark "a" or below → Add.



**Specified brake fluid
DOT 4**

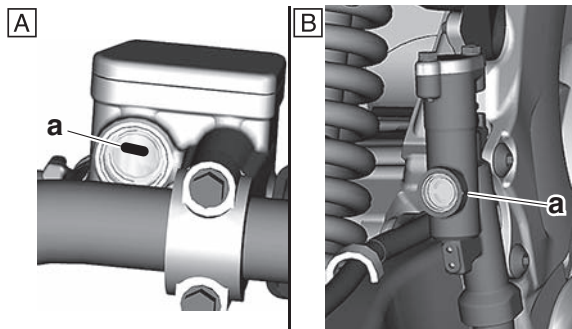

- A. Front brake
- B. Rear brake

EWA13090

WARNING

- **Use only the designated brake fluid. Other brake fluids may cause the rubber seals to deteriorate, causing leakage and poor brake performance.**
- **Refill with the same type of brake fluid that is already in the system. Mixing brake fluids may result in a harmful chemical reaction, leading to poor brake performance.**
- **When refilling, be careful that water does not enter the brake fluid reservoir. Water will significantly lower the boiling point of the brake fluid and could cause vapor lock.**

ECA13540

NOTICE

Brake fluid may damage painted surfaces and plastic parts. Therefore, always clean up any spilt brake fluid immediately.

EAM30231

CHECKING THE FRONT BRAKE PADS

The following procedure applies to all of the brake pads.

1. Operate the brake.
2. Check:
 - **Front brake pad**
Wear indicator grooves "1" almost touch the brake disc → Replace the brake pads as a set.
Refer to "FRONT BRAKE" on page 4-7.

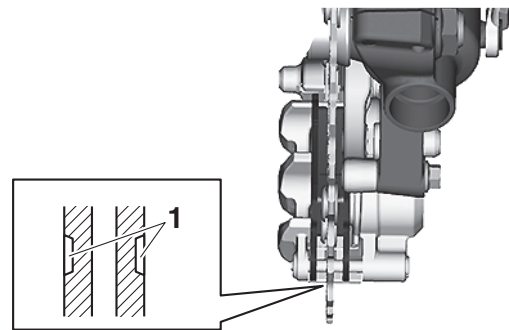

EAM30232

CHECKING THE REAR BRAKE PADS

The following procedure applies to all of the brake pads.

1. Operate the brake.
2. Check:
 - **Rear brake pad**
Wear indicator grooves "1" almost disappeared → Replace the brake pads as a set.
Refer to "REAR BRAKE" on page 4-9.

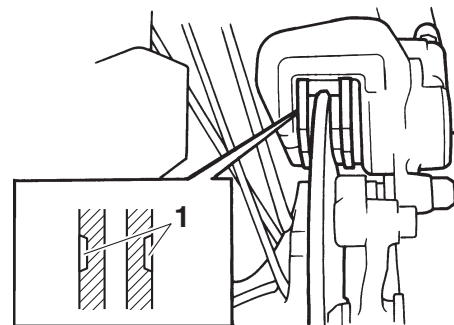

EAM30478

CHECKING THE FRONT BRAKE HOSE

1. Check:
 - **Brake hose**
Cracks/damage/wear → Replace.
2. Check:
 - **Brake hose clamp**
Loose connection → Tighten the clamp bolt.
3. Stand the vehicle upright and apply the front brake several times.
4. Check:
 - **Brake hose**
Brake fluid leaks → Replace the damaged brake hose.

EAM30498

CHECKING THE REAR BRAKE HOSE

1. Check:
 - **Brake hose**
Cracks/damage/wear → Replace.
2. Check:
 - **Brake hose holder**
Loose connection → Tighten the holder bolt.

3. Hold the vehicle upright and apply the rear brake several times.
4. Check:
 - Brake hose
Brake fluid leakage → Replace the damaged hose.

EAM30499

CHECKING THE BRAKE OPERATION

1. Check:
 - Brake operation
Brake not working properly → Check the brake system.

TIP

Drive on the dry road, operate the front and rear brakes separately and check to see if the brakes are operating properly.

EAM30477

BLEEDING THE HYDRAULIC BRAKE SYSTEM

EWA19140

⚠ WARNING

Bleed the brake system whenever:

- The system is disassembled.
- A brake hose is loosened, disconnected, or replaced.
- The brake fluid level is very low.
- Brake operation is faulty.

1. Remove:
 - Brake master cylinder cap
 - Reservoir diaphragm
 - Reservoir float (front brake)
 - Protector (rear brake)

TIP

- Be careful not to spill any brake fluid or allow the reservoir to overflow.
- Make sure that there is enough brake fluid before applying the brake. Ignoring this precaution could allow air to enter the brake system, considerably lengthening the bleeding procedure.
- If bleeding is difficult, it may be necessary to let the brake fluid settle for a few hours. Repeat the bleeding procedure when the tiny bubbles in the hose have disappeared.

2. Bleed the brake system.
 - a. Fill the reservoir to the proper level with the recommended brake fluid.
 - b. Install the reservoir diaphragm.
 - c. Connect the plastic hose “1” to the bleed screw “2” securely, and place a container under the end of the plastic hose.

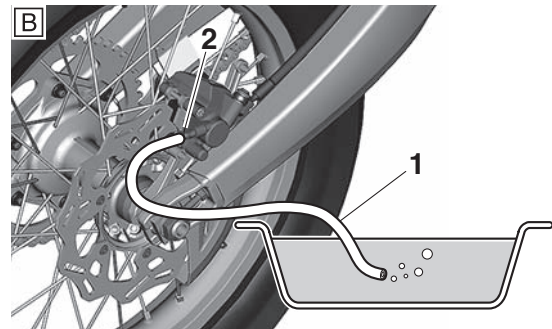
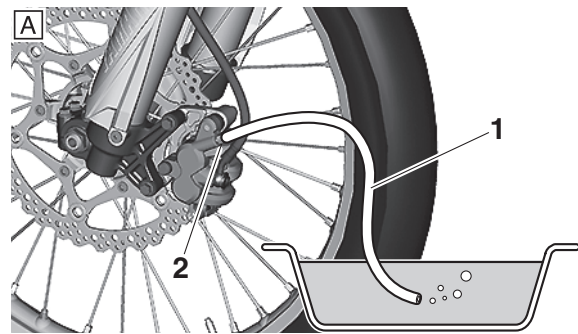

- A. Front
B. Rear

- d. Slowly apply the brake several times.
- e. Fully pull the brake lever or fully press down the brake pedal and hold it in position.
- f. Loosen the bleed screw.

TIP

Loosening the bleed screw will release the pressure in the brake caliper and cause the brake lever to contact the throttle grip or the brake pedal to fully extend.

- g. Tighten the bleed screw and then release the brake lever or brake pedal.
- h. Repeat steps (d) to (g) until all of the air bubbles have disappeared from the brake fluid in the plastic hose.

TIP

During the procedure, keep adding brake fluid to the reservoir.

ECA24320

NOTICE

- Wipe off any brake fluid on the brake discs, tires, wheels, etc.
- Brake fluid may erode painted surfaces or plastic parts. Always clean up spilled fluid immediately.

- i. Tighten the bleed screw.



Bleed screw
5 N·m (0.5 kgf·m, 3.7 lb·ft)

- j. Pour brake fluid to the reservoir up to the specified level.
Refer to “CHECKING THE BRAKE FLUID LEVEL” on page 3-19.

EWA13110



WARNING

After bleeding the hydraulic brake system, check the brake operation.

EAM30481

DRIVE CHAIN SLACK

ECA13550

NOTICE

A drive chain that is too tight will overload the engine and other vital parts, and one that is too loose can skip and damage the swingarm or cause an accident. Therefore, keep the drive chain slack within the specified limits.

Checking the drive chain slack

1. Use a maintenance stand to raise the rear wheel off the ground.

EWA13120



WARNING

Securely support the vehicle so that there is no danger of it falling over.

2. Shift the transmission into the neutral position.
3. Pull the drive chain up above the drive chain guide installation bolt with a force of about 50 N (5.0 kgf, 37 lbf).
4. Check:
 - Drive chain slack “a”
 Out of specification → Regulate.

TIP

Measure drive chain slack between the drive chain guide and the bottom of the chain as shown.

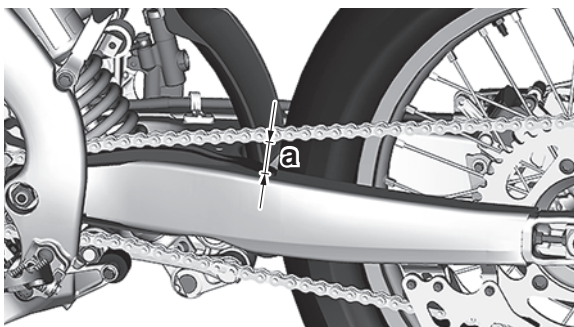

Drive chain slack (Maintenance Stand)
50.0–60.0 mm (1.97–2.36 in)

Adjusting the drive chain slack

EWA13120



WARNING

Securely support the vehicle so that there is no danger of it falling over.

1. Adjust:
 - Drive chain slack
 - a. Loosen the wheel axle nut “1”.
 - b. Loosen both locknuts “2”.
 - c. Turn the adjusting bolt “3” until the specified drive chain slack is obtained.

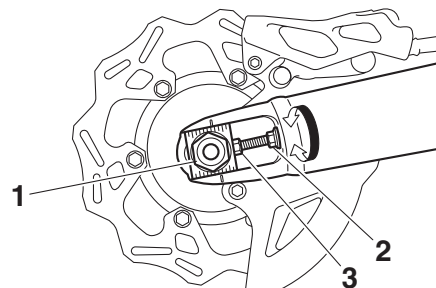

TIP

- To maintain the proper wheel alignment, adjust both sides evenly.
 - Push the rear wheel forward to make sure that there is no clearance between the swingarm end plates and the ends of the swingarm.
- d. Tighten the wheel axle nut.



Wheel axle nut
125 N·m (12.5 kgf·m, 92 lb·ft)

- e. Tighten the drive chain puller locknut.



Drive chain puller locknut
21 N·m (2.1 kgf·m, 15 lb·ft)

EAM30251

LUBRICATING THE DRIVE CHAIN

The drive chain consists of many interacting parts. If the drive chain is not maintained properly, it will wear out quickly. Therefore, the drive chain should be serviced, especially when the vehicle is used in dusty areas.

This vehicle has a drive chain with small rubber O-rings between each side plate. Steam cleaning, high-pressure washing, certain solvents, and the use of a coarse brush can damage these O-rings. Therefore, use only kerosene to

clean the drive chain. Wipe the drive chain dry and thoroughly lubricate it with engine oil or chain lubricant that is suitable for O-ring chains. Do not use any other lubricants on the drive chain since they may contain solvents that could damage the O-rings.

| | |
|---|--|
|  | Recommended lubricant Chain lubricant suitable for O-ring chains |
|---|--|

EAM30247

CHECKING AND ADJUSTING THE STEERING HEAD

1. Use a maintenance stand to raise the front wheel off the ground.

EWA13120

WARNING

Securely support the vehicle so that there is no danger of it falling over.

2. Check:
 - Steering head
Grasp the bottom of the front fork legs and gently rock the front fork.
Blinding/looseness → Adjust the steering head.
3. Remove:
 - Handlebar
 - Upper bracket
4. Adjust:
 - Steering head
 - a. Remove the washer "1".

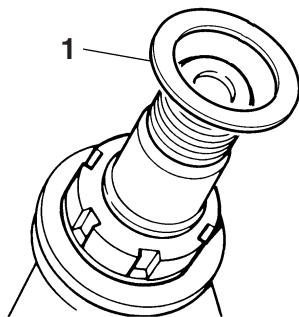

- b. After loosening the ring nut "2" with a steering nut wrench "3", tighten it to the specified torque.

TIP

- Set the torque wrench at a right angle to the steering nut wrench.
- Move the steering to the left and right a couple of times to check that it moves smoothly.

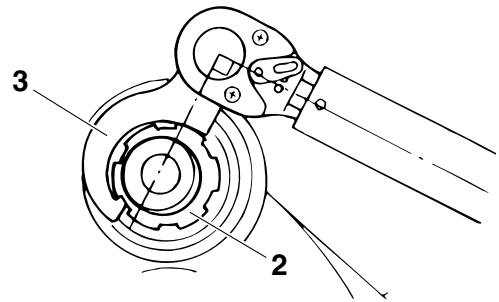

| | |
|---|---|
|  | Steering nut wrench 90890-01403 Exhaust flange nut wrench YU-A9472 |
|---|---|

| | |
|---|---|
|  | Ring nut (initial tightening torque) 38 N·m (3.8 kgf·m, 28 lb·ft) |
|---|---|

- c. Turn the front fork to the right and left a few times, and make sure that the steering rotates smoothly. If it does not turn smoothly, remove the lower bracket and check the upper and lower bearings.
Refer to "STEERING HEAD" on page 4-27.
- d. Loosen the ring nut fully turn and then tighten it to specification with a steering nut wrench.

EWA13140

WARNING

Do not overtighten the lower ring nut.

| | |
|---|---|
|  | Ring nut (final tightening torque) 7 N·m (0.7 kgf·m, 5.2 lb·ft) |
|---|---|

- e. Check the steering head for looseness or binding by turning the front fork all the way in both directions. If any binding is felt, remove the lower bracket and check the upper and lower bearings.
Refer to "STEERING HEAD" on page 4-27.
- f. Install the washer "1".

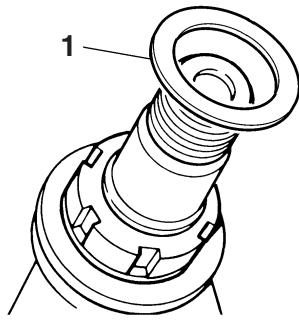

5. Install:
- Upper bracket
 - Handlebar
- Refer to "HANDLEBAR" on page 4-11.

EAM30502

LUBRICATING THE STEERING HEAD

1. Lubricate:
- Upper bearing
 - Lower bearing
 - Bearing race



EAM30338

CHECKING THE FRONT FORK LEGS

1. Stand the vehicle upright on a level surface.

EWA13120



WARNING

Securely support the vehicle so that there is no danger of it falling over.

2. Check:
- Inner tube
Damage/scratches → Replace.
 - Front fork leg
Oil leaks between inner tube and outer tube → Replace the oil seal.
3. Hold the vehicle upright and apply the front brake.
4. Check:
- Front fork operation
Push down hard on the handlebar several times and check if the front fork rebounds smoothly.
Unsmooth operation → Correct or replace.
Refer to "FRONT FORK" on page 4-16.

TIP
If any damage is found or the front fork does not operate smoothly, have a Yamaha dealer check or repair it.

5. Check:
- Protector guide "1"

Out of specification → Replace.

TIP
The protector guide reaches the limit of its use when it is worn down to the same height "a" as of the outer tube circumference.

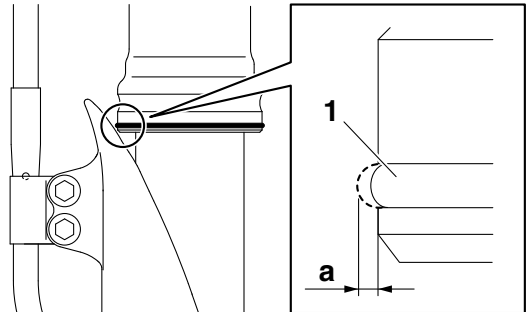

6. Remove:
- Protector
 - Dust seal "1"

ECA24330

NOTICE

Be careful not to damage the dust seal and the inner tube by a driver.

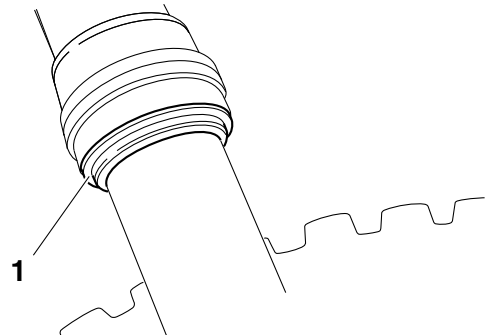

7. Clean:
- Dust seal "a"
 - Scraper "b"
 - Oil seal "c"

TIP
• Clean the dust seal, scraper and oil seal after every run.
• Apply lithium-soap-based grease on the inner tube.

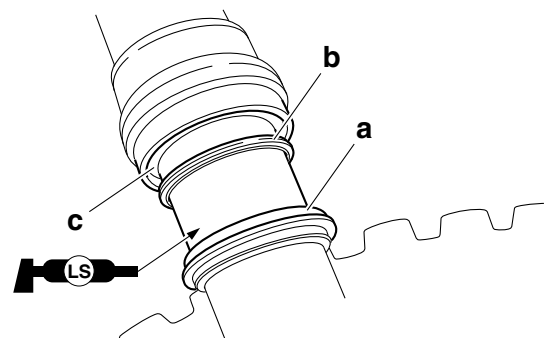

EAM30239

ADJUSTING THE FRONT FORK LEGS

EWA19180

WARNING

- Always adjust the left and right front forks evenly. If this is not done, the vehicle may have poor stability.
- Securely support the vehicle so that there is no danger of it falling over.

Rebound damping

ECA24340

NOTICE

Do not turn the adjuster forcibly beyond its adjusting range.

1. Adjust:
 - Rebound damping
 - a. Turn the adjuster "1" in the direction of "a" or "b" to make an adjustment.

Direction "a"

Rebound damping is increased (suspension is harder).

Direction "b"

Rebound damping is decreased (suspension is softer).



Rebound damping

Minimum (soft)

20 click(s) in direction "b"*

Standard

8 click(s) in direction "b"*

Maximum (hard)

0 click(s) in direction "b"*

* With the adjusting screw fully turned in direction "a"

TIP

Although the total number of clicks of a damping force adjusting mechanism may not exactly match the above specifications due to small differences in production, the actual number of clicks always represents the entire adjusting range. To obtain a precise adjustment, it would be advisable to check the number of clicks of each damping force adjusting mechanism and to modify the specifications as necessary.

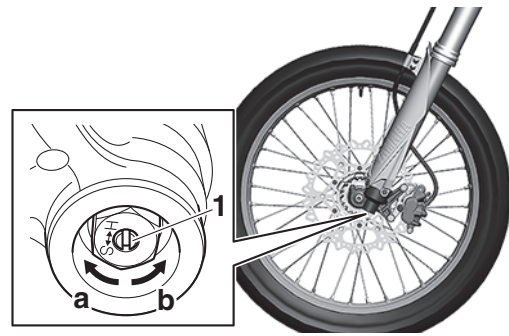

Compression damping

ECA24350

NOTICE

Do not turn the adjuster forcibly beyond its adjusting range.

1. Adjust:
 - Compression damping
 - a. Turn the adjuster "1" in the direction of "a" or "b" to make an adjustment.

Direction "a"

Compression damping is increased (suspension is harder).

Direction "b"

Compression damping is decreased (suspension is softer).



Compression damping

Minimum (soft)

20 click(s) in direction "b"*

Standard

12 click(s) in direction "b"*

Maximum (hard)

0 click(s) in direction "b"*

* With the adjusting screw fully turned in direction "a"

TIP

Although the total number of clicks of a damping force adjusting mechanism may not exactly match the above specifications due to small differences in production, the actual number of clicks always represents the entire adjusting range. To obtain a precise adjustment, it would be advisable to check the number of clicks of each damping force adjusting mechanism and to modify the specifications as necessary.

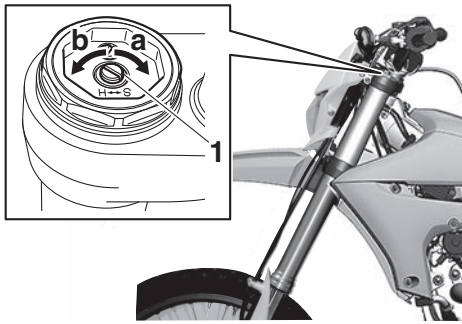

Air bleeding from front fork

TIP

If the front fork initial movement feels stiff during a run, relieve the front fork internal pressure.

1. Use a maintenance stand to raise the front wheel off the ground.

EWA13120

WARNING

Securely support the vehicle so that there is no danger of it falling over.

2. Remove the bleed screw "1" and release the internal pressure from the front fork.
3. Tighten:
 - Bleed screw



Bleed screw

1.3 N·m (0.13 kgf·m, 0.95 lb·ft)

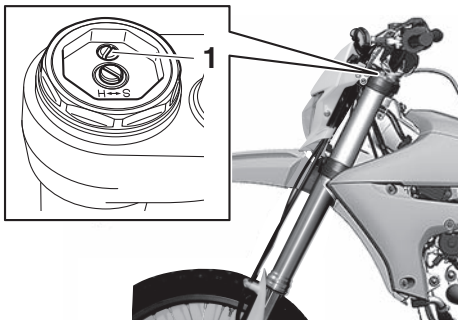

EAM30482

CHECKING THE REAR SHOCK ABSORBER ASSEMBLY

1. Stand the vehicle upright on a level surface.

EWA13120

WARNING

Securely support the vehicle so that there is no danger of it falling over.

2. Check:
 - Rear shock absorber assembly
Gas leaks/oil leaks → Replace the rear shock absorber assembly.
Refer to "REAR SHOCK ABSORBER ASSEMBLY" on page 4-30.

3. Check:

- Rear shock absorber assembly smooth action
- Rear suspension link smooth action
Sit astride the seat and shake your body up and down several times to check whether the rear shock absorber assembly operates smoothly.
Unsmooth operation → Correct or replace.

EAM30242

ADJUSTING THE REAR SHOCK ABSORBER ASSEMBLY

Use a maintenance stand to raise the rear wheel off the ground.

EWA13120

WARNING

Securely support the vehicle so that there is no danger of it falling over.

Spring preload

ECA24360

NOTICE

Do not turn the adjuster forcibly beyond its adjusting range.

1. Adjust:

- Spring preload
 - a. Loosen the locknut "1".
 - b. Loosen the adjuster "2" until there is some clearance between the spring and the adjuster.
 - c. Measure the spring free length "a".

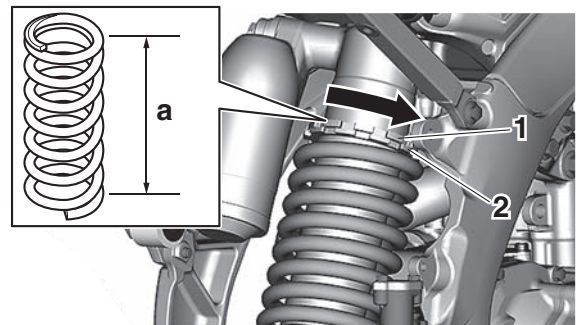

- d. Turn the adjuster in the direction of "b" or "c" to make an adjustment.

Direction "b"

Spring preload is increased (suspension is harder).

Direction "c"

Spring preload is decreased (suspension is softer).



Spring preload adjusting positions

Minimum

Position in which the spring is turned in 1.5 mm (0.06 in) from its free length.

Standard

Position in which the spring is turned in 10.0 mm (0.39 in) from its free length.

Maximum

Position in which the spring is turned in 18.0 mm (0.71 in) from its free length.

TIP

- Be sure to remove all dirt and mud from around the locknut and adjusting ring before adjustment.
- The length of the spring (installed) changes 1.5 mm (0.06 in) per turn of the adjusting ring.

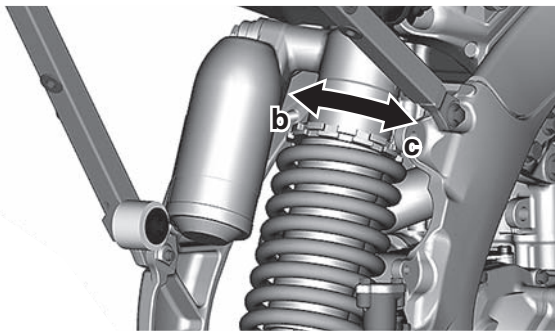

e. Tighten the locknut.

Rebound damping

ECA24370

NOTICE

Do not turn the adjuster forcibly beyond its adjusting range.

1. Adjust:
 - Rebound damping
 - a. Turn the adjuster "1" in the direction of "a" or "b" to make an adjustment.

Direction "a"

Rebound damping is increased (suspension is harder).

Direction "b"

Rebound damping is decreased (suspension is softer).



Rebound damping

Minimum (soft)

30 click(s) in direction "b"*

Standard

8 click(s) in direction "b"*

Maximum (hard)

0 click(s) in direction "b"

* With the adjusting screw fully turned in direction "a"

TIP

Although the total number of clicks of a damping force adjusting mechanism may not exactly match the above specifications due to small differences in production, the actual number of clicks always represents the entire adjusting range. To obtain a precise adjustment, it would be advisable to check the number of clicks of each damping force adjusting mechanism and to modify the specifications as necessary.

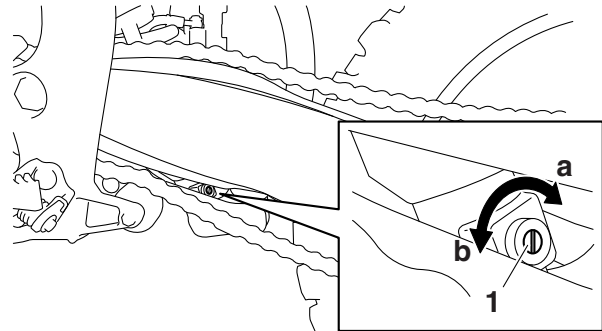

Compression damping (for fast compression damping)

ECA24370

NOTICE

Do not turn the adjuster forcibly beyond its adjusting range.

1. Adjust:
 - Compression damping (for fast compression damping)
 - a. Turn the adjuster "1" in the direction of "a" or "b" to make an adjustment.

Direction "a"

Compression damping is increased (suspension is harder).

Direction "b"

Compression damping is decreased (suspension is softer).



Fast compression damping
Minimum (soft)
 2 turn(s) in direction “b”^{*}
Standard
 1 turn(s) in direction “b”^{*}
Maximum (hard)
 0 turn(s) in direction “b”^{*}
^{*}With the adjusting screw fully turned in direction “a”

TIP

To obtain a precise adjustment, it is advisable to check the actual total number of turns of the damping force adjusting mechanism. This adjustment range may not exactly match the specifications listed due to small differences in production.

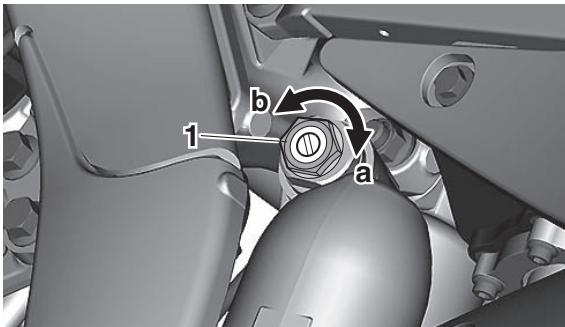

Compression damping (for slow compression damping)

ECA24390

NOTICE

Do not turn the adjuster forcibly beyond its adjusting range.

1. Adjust:
 - Compression damping (for slow compression damping)
 - a. Turn the adjuster “1” in the direction of “a” or “b” to make an adjustment.

Direction “a”
Compression damping is increased (suspension is harder).
Direction “b”
Compression damping is decreased (suspension is softer).



Slow compression damping
Minimum (soft)
 20 click(s) in direction “b”^{*}
Standard
 10 click(s) in direction “b”^{*}
Maximum (hard)
 0 click(s) in direction “b”^{*}
^{*}With the adjusting screw fully turned in direction “a”

TIP

Although the total number of clicks of a damping force adjusting mechanism may not exactly match the above specifications due to small differences in production, the actual number of clicks always represents the entire adjusting range. To obtain a precise adjustment, it would be advisable to check the number of clicks of each damping force adjusting mechanism and to modify the specifications as necessary.

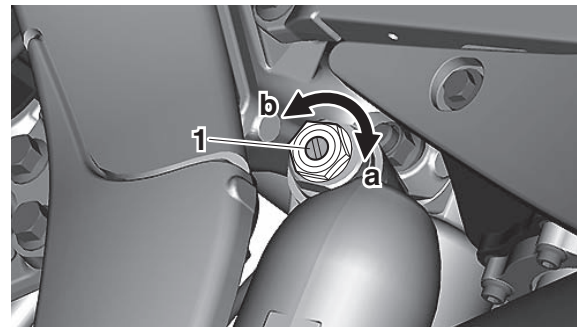

EAM30240

CHECKING THE SWINGARM OPERATION

1. Check:
 - Swingarm smooth action
 - Swingarm free play
 Refer to “SWINGARM” on page 4-31.

EAM30500

LUBRICATING THE SWINGARM PIVOT

1. Lubricate:
 - Oil seal
 - Collar



Recommended lubricant
Lithium-soap-based grease

EAM30243

CHECKING THE TIRES

1. Measure:
 - Tire pressure
 Out of specification → Regulate.



Tire air pressure (measured on cold tires)
Front
 100 kPa (1.00 kgf/cm², 15 psi)
Rear
 100 kPa (1.00 kgf/cm², 15 psi)

TIP

- Check the tire while it is cold.
- Because if the bead stopper tightening nut is loose when the tire pressure is low, the tire could slip off the rim, thus be sure to check and tighten the bead stopper tightening nut “a”.
- If the tire valve stem “b” is found tilted, the tire is considered to be slipping off its position. Correct the tire position.

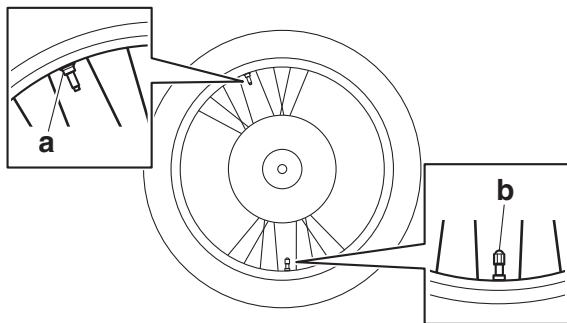

- a. Bead stopper tightening nut
 b. Tire valve stem

EAM30244

CHECKING AND TIGHTENING THE SPOKES

1. Check:

- Spoke
 Bend/damage → Replace.
 Loose → Tighten.
 Tap the spokes with a screwdriver.

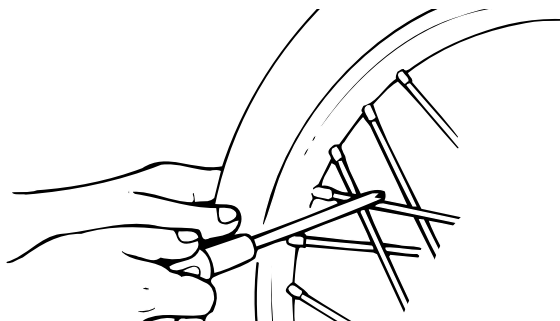

TIP

A tight spoke will emit a clear, ringing tone; a loose spoke will sound flat.

2. Tighten:

- Spoke
 (with a spoke nipple wrench “1”)

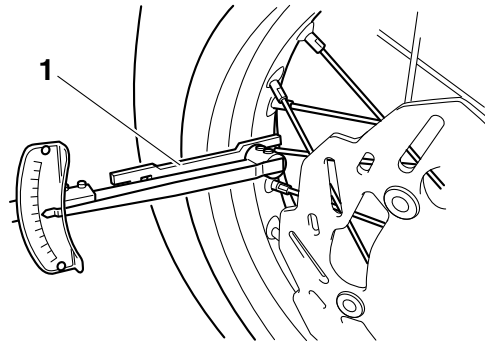

Spoke nipple wrench (6-7)
 90890-01521
Spoke nipple wrench (6-7)
 YM-01521



Spoke
 2.5 N·m (0.25 kgf·m, 1.8 lb·ft)

TIP

- Do not give a half turn (180°) or more for one tightening.
- Make sure that tightening after a break-in is done until the initial looseness in nipples disappears.
- Make sure that tightening is done in stages, not at a time.

EAM30245

CHECKING THE WHEELS

1. Check:

- Wheel
 Damage/out-of-round → Replace.

EWA13260



WARNING

Never attempt to make any repairs to the wheel.

EAM30253

CHECKING THE CHASSIS FASTENERS

Make sure that all nuts, bolts, and screws are properly tightened.

Refer to “CHASSIS TIGHTENING TORQUES” on page 2-12.

EAM30248

CHECKING AND LUBRICATING THE CABLES

The following procedure applies to all of the inner and outer cables.

EWA13270



WARNING

Damaged outer cable may cause the cable to corrode and interfere with its movement. Re-

place damaged outer cable and inner cables as soon as possible.

1. Check:
 - Outer cable
Damage → Replace.
2. Check:
 - Cable operation
Rough movement → Lubricate.

| | |
|---|--|
|  | Recommended lubricant Lithium-soap-based grease |
|---|--|

| | |
|---|---|
|  | Recommended lubricant Engine oil or a suitable cable lubricant |
|---|---|

TIP

Hold the cable end upright and pour a few drops of lubricant into the cable sheath or use a suitable lubricating device.

EAM30483

LUBRICATING THE BRAKE LEVER

1. Lubricate the pivoting points and metal-to-metal moving parts of the following parts.
 - Brake lever

| | |
|---|--|
|  | Recommended lubricant Silicone grease |
|---|--|

EAM30503

LUBRICATING THE CLUTCH LEVER

1. Lubricate the pivoting points and metal-to-metal moving parts of the following parts.
 - Clutch lever

| | |
|---|--|
|  | Recommended lubricant Lithium-soap-based grease |
|---|--|

EAM30250

LUBRICATING THE PEDAL

1. Lubricate the pivoting point and metal-to-metal moving parts of the pedal.

| | |
|---|--|
|  | Recommended lubricant Lithium-soap-based grease |
|---|--|

EAM30504

CHECKING THE SIDESTAND

1. Check:
 - Sidestand operation
Check that the sidestand moves smoothly.
Rough movement → Repair or replace.

EAM30252

LUBRICATING THE SIDESTAND

Lubricate the pivoting point and metal-to-metal moving parts of the sidestand.

EAM20137

ELECTRICAL SYSTEM

EAM30256

CHECKING AND CHARGING THE BATTERY

Refer to “CHECKING AND CHARGING THE BATTERY” on page 7-4.

EAM30505

CHECKING THE FUSES

Refer to “CHECKING THE FUSES” on page 7-3.

EAM30339

REPLACING THE HEADLIGHT BULB

EWA13320

⚠ WARNING

Since the headlight bulb gets extremely hot, keep flammable products and your hands away from the bulb until it has cooled down.

1. Remove:
 - Headlight unit bolt “1”

TIP

After you have removed the headlight unit bolts, lift and remove the headlight unit.

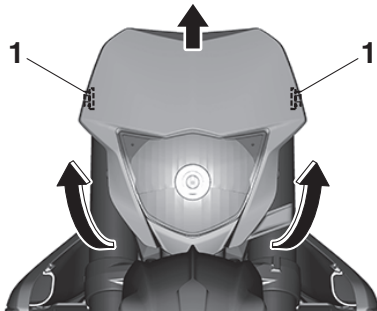

2. Remove:
 - Headlight coupler “1”
 - Bulb cover “2”

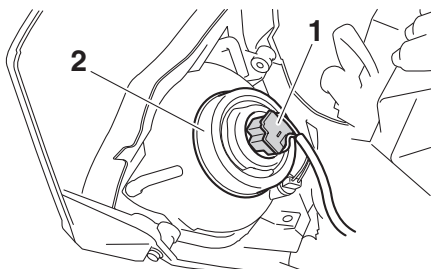

3. Remove:
 - Headlight bulb “1”

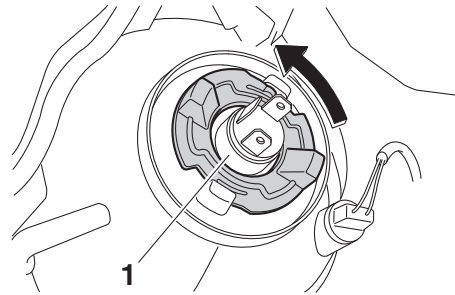

4. Install:
 - Headlight bulb **New**
 Fasten the new headlight bulb with the headlight bulb holder.

ECA13690

NOTICE

Avoid touching the glass part of the headlight bulb to keep it free from oil, otherwise the transparency of the glass, the life of the bulb and the luminous flux will be adversely affected. If the headlight bulb gets soiled, thoroughly clean it with a cloth moistened with alcohol or lacquer thinner.

5. Install:
 - Bulb cover
 - Headlight coupler
6. Install:
 - Headlight unit



Headlight unit bolt
7 N·m (0.7 kgf·m, 5.2 lb·ft)

CHASSIS

| | |
|--|------|
| GENERAL CHASSIS | 4-1 |
| REMOVING THE SEAT | 4-1 |
| INSTALLING THE AIR SCOOP | 4-1 |
| REMOVING THE SIDE COVER..... | 4-1 |
| INSTALLING THE SIDE COVER | 4-1 |
| | |
| FRONT WHEEL | 4-3 |
| REMOVING THE FRONT WHEEL..... | 4-3 |
| INSTALLING THE FRONT WHEEL | 4-3 |
| | |
| REAR WHEEL | 4-5 |
| REMOVING THE REAR WHEEL | 4-5 |
| CHECKING AND REPLACING THE REAR WHEEL SPROCKET | 4-5 |
| INSTALLING THE REAR WHEEL..... | 4-5 |
| | |
| FRONT BRAKE | 4-7 |
| REPLACING THE FRONT BRAKE PADS | 4-7 |
| | |
| REAR BRAKE | 4-9 |
| REPLACING THE REAR BRAKE PADS..... | 4-9 |
| | |
| HANDLEBAR | 4-11 |
| REMOVING THE HANDLEBAR..... | 4-11 |
| CHECKING THE HANDLEBAR | 4-11 |
| INSTALLING THE HANDLEBAR | 4-11 |
| | |
| FRONT FORK | 4-16 |
| REMOVING THE FRONT FORK LEGS..... | 4-16 |
| DISASSEMBLING THE FRONT FORK LEGS | 4-16 |
| CHECKING THE FRONT FORK LEGS | 4-17 |
| ASSEMBLING THE FRONT FORK LEGS..... | 4-18 |
| INSTALLING THE FRONT FORK LEGS | 4-24 |
| | |
| STEERING HEAD | 4-27 |
| REMOVING THE LOWER BRACKET..... | 4-27 |
| CHECKING THE STEERING HEAD | 4-27 |
| INSTALLING THE STEERING HEAD | 4-27 |
| | |
| REAR SHOCK ABSORBER ASSEMBLY | 4-30 |
| REMOVING THE REAR SHOCK ABSORBER ASSEMBLY..... | 4-30 |
| CHECKING THE REAR SHOCK ABSORBER ASSEMBLY | 4-30 |
| | |
| SWINGARM | 4-31 |
| REMOVING THE SWINGARM..... | 4-31 |

| | |
|---------------------------------------|------|
| CHAIN DRIVE | 4-32 |
| REMOVING THE DRIVE CHAIN..... | 4-32 |
| CHECKING THE DRIVE CHAIN | 4-32 |
| CHECKING THE DRIVE SPROCKET..... | 4-33 |
| CHECKING THE REAR WHEEL SPROCKET..... | 4-33 |
| INSTALLING THE DRIVE CHAIN | 4-33 |

EAM20094

GENERAL CHASSIS

EAM30016

REMOVING THE SEAT

TIP

The fuel tank cap cover and the seat are coupled with each other with a plastic band. When removing the seat, always remove the fuel tank cap cover beforehand.

1. Remove:

- Fuel tank cap cover "1"
Refer to "FUEL TANK CAP" on page 1-14.

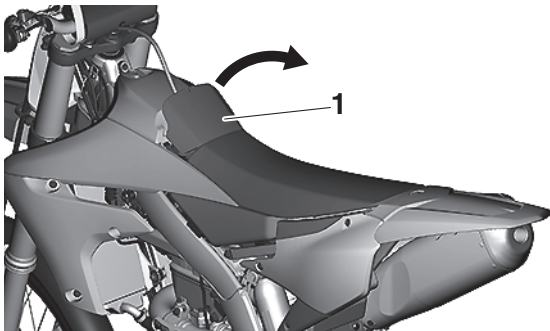

2. Remove:

- Seat "1"

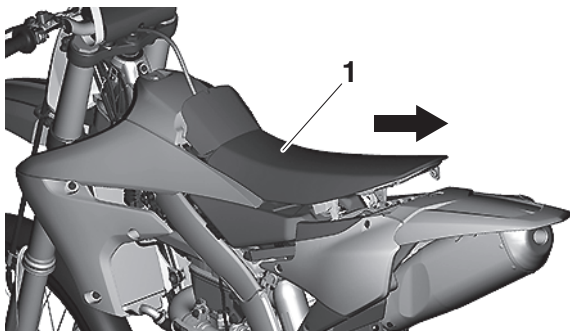

EAM30458

INSTALLING THE AIR SCOOP

1. Install:

- Air scoop (left "1"/right)

TIP

After inserting the projection "a" on the air scoop (left/right) into the hole "b" in the air filter case, inserting the grooves "c" into the ribs "d" of the air filter case, and inserting the projection "e" into the slot "f" in the air filter case, install the air scoop and secure it with the bolts.

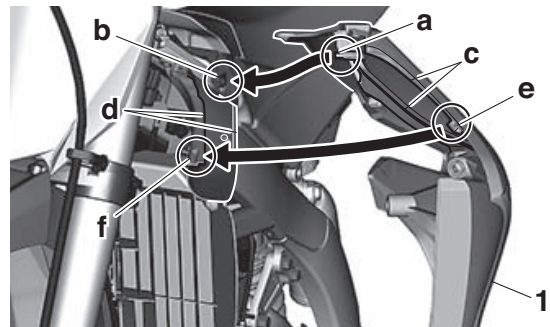

EAM30459

REMOVING THE SIDE COVER

1. Remove:

- Side cover (right) "1"

TIP

Remove the side cover (right) from the vehicle by removing the bolts and sliding it as shown.

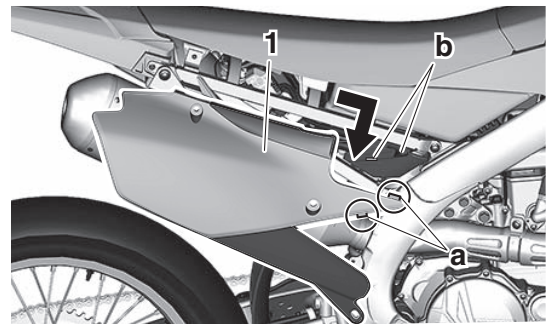

- a. Projection
- b. Slot

EAM30460

INSTALLING THE SIDE COVER

1. Install:

- Side cover (right) "1"

TIP

- Install the side cover (right) by sliding it as shown and secure it with the bolts to fit it to the vehicle.
- Install the side cover (right) so that the rib is located under the rib of the rear fender.

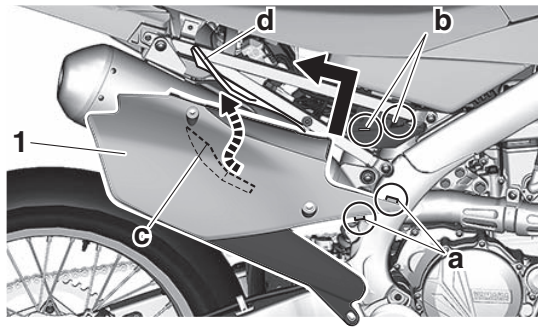

- a. Projection
- b. Slot
- c. Rib (side cover)
- d. Rib (rear fender)

EAM20095

FRONT WHEEL

EAM30017

REMOVING THE FRONT WHEEL

ECA22340

NOTICE

- Keep any type of magnets (including magnetic pick-up tools, magnetic screwdrivers, etc.) away from the speed sensor or speed sensor rotor; otherwise, the sensor or rotor may be damaged, resulting in improper operation.
- Do not drop the speed sensor rotor or subject it to shocks.
- If any solvent gets on the speed sensor rotor, wipe it off immediately.

1. Use a maintenance stand to raise the front wheel off the ground.

EWA13120

WARNING

Securely support the vehicle so that there is no danger of it falling over.

2. Remove:
 - Front wheel

EAM30021

INSTALLING THE FRONT WHEEL

1. Install:
 - Front wheel

TIP

Install the brake disc "1" between the brake pads "2" correctly.

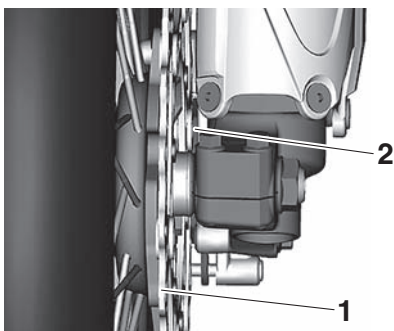

2. Install:
 - Front wheel sensor
 - Front wheel sensor bracket

| | |
|---|--|
|  | Front wheel sensor bolt 7 N·m (0.7 kgf·m, 5.2 lb·ft) |
|---|--|

ECA21020

NOTICE

Make sure there are no foreign materials in the front wheel sensor rotor and front wheel

sensor. Foreign materials cause damage to the front wheel sensor rotor and front wheel sensor.

TIP

When installing the front wheel sensor, check the wheel sensor lead for twists.

3. Install:
 - Front wheel axle "1"

TIP

Apply the lithium-soap-based grease to the front wheel axle.

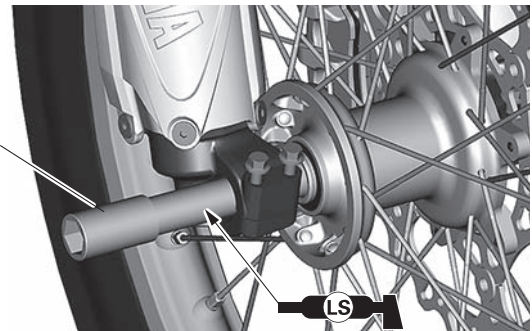

4. Tighten:
 - Front wheel axle nut "1"

| | |
|---|---|
|  | Front wheel axle nut 115 N·m (11.5 kgf·m, 85 lb·ft) |
|---|---|

ECA24430

NOTICE

Before tightening the front wheel axle nut, push down hard on the handlebar(s) several times and check if the front fork rebounds smoothly.



5. Tighten:
 - Front wheel axle pinch bolt "1"

| | |
|---|--|
|  | Front wheel axle pinch bolt 21 N·m (2.1 kgf·m, 15 lb·ft) |
|---|--|

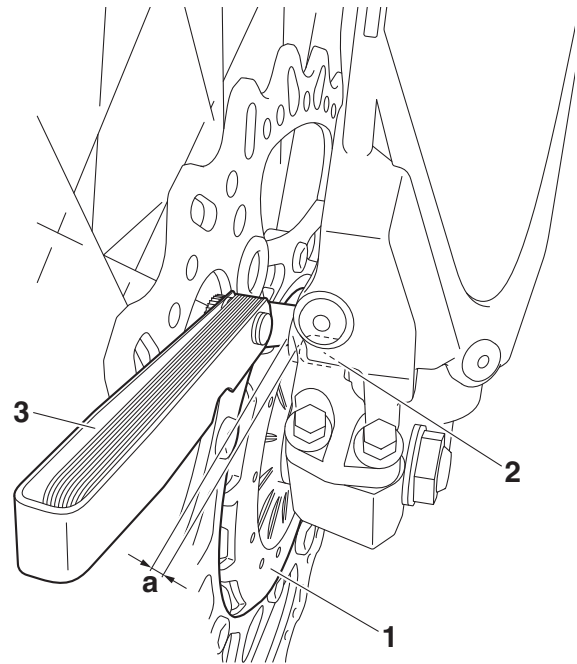
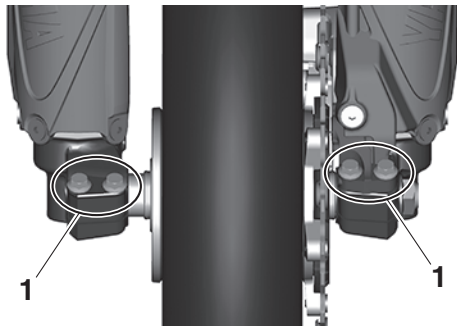

6. Measure:

- Distance “a”
(between the wheel sensor rotor “1” and front wheel sensor “2”)
Out of specification → Check the wheel bearing for looseness, and the front wheel sensor and sensor rotor installation conditions (warpage caused by overtorque, wrong installation direction, rotor decentering, LOC-TITE® on the mounting surface of the rotor, deformation caused by an impact during service and caught foreign materials). If there is any defective part, repair or replace the defective part.



Distance “a” (between the wheel sensor rotor and front wheel sensor)
0.2–1.7 mm (0.008–0.067 in)

TIP

Measure the distance between the front wheel sensor rotor and front wheel sensor in several places in one rotation of the front wheel. Do not turn the front wheel while the thickness gauge “3” is installed. This may damage the front wheel sensor rotor and the front wheel sensor.



Thickness gauge
90890-03268
Feeler gauge set
YU-26900-9

EAM20096

REAR WHEEL

EAM30022

REMOVING THE REAR WHEEL

1. Use a maintenance stand to raise the rear wheel off the ground.

EWA13120

WARNING

Securely support the vehicle so that there is no danger of it falling over.

2. Remove:
 - Rear wheel axle nut "1"
3. Loosen:
 - Locknut "2"
4. Tighten:
 - Adjusting bolt "3"

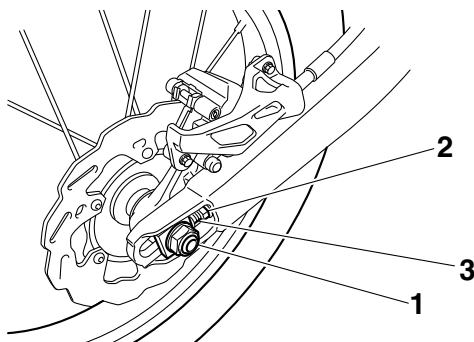

5. Remove:
 - Rear wheel axle
 - Rear wheel

TIP

- Push the rear wheel forward and remove the drive chain from the rear wheel sprocket.
- Do not depress the brake pedal with the rear wheel removed.

EAM30025

CHECKING AND REPLACING THE REAR WHEEL SPROCKET

1. Check:
 - Rear wheel sprocket
 - More than 1/4 tooth wear "a" → Replace the rear wheel sprocket and the drive sprocket as a set.
 - Bent tooth → Replace the rear wheel sprocket and the drive sprocket as a set.

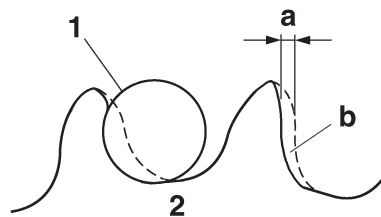

- b. Correct
 1. Drive chain roller
 2. Rear wheel sprocket

2. Replace:
 - Rear wheel sprocket
 - a. Remove the self-locking nuts and the rear wheel sprocket.
 - b. Clean the rear wheel drive hub with a clean cloth, especially the surfaces that contact the sprocket.
 - c. Install the new rear wheel sprocket.



Rear wheel sprocket self-locking nut
50 N·m (5.0 kgf·m, 37 lb·ft)

TIP

Tighten the self-locking nuts in stages and in a crisscross pattern.

EAM30027

INSTALLING THE REAR WHEEL

1. Install:
 - Rear wheel

TIP

Install the brake disc "1" between the brake pads "2" correctly.

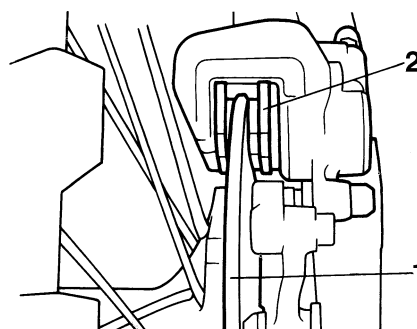

2. Install:
 - Drive chain "1"

TIP

Push the rear wheel "2" forward and install the

REAR WHEEL

drive chain.

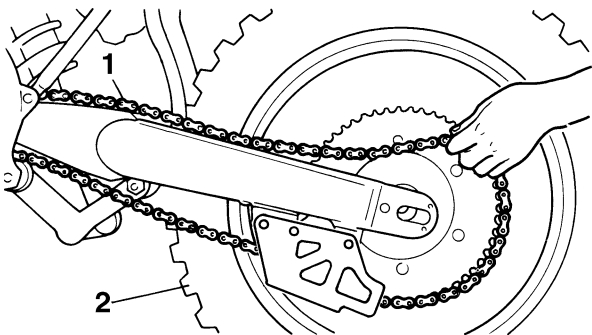

3. Install:

- Drive chain puller (left) "1"
- Rear wheel axle "2"

TIP

- Install the drive chain puller (left), and insert the rear wheel axle from the left side.
- Apply the lithium-soap-based grease to the rear wheel axle.

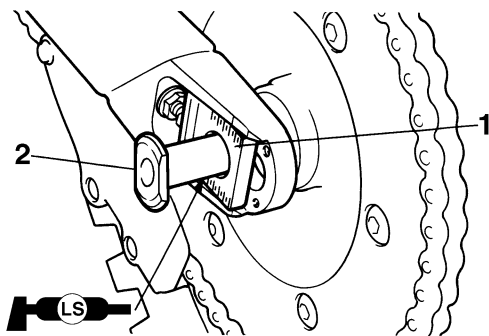

4. Install:

- Drive chain puller (right) "1"
- Washer "2"
- Rear wheel axle nut "3"

TIP

Temporarily tighten the rear wheel axle nut at this point.

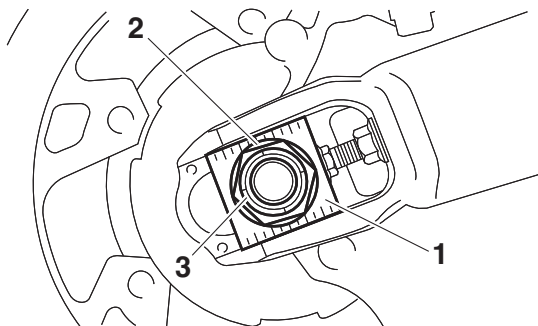

5. Adjust:

- Drive chain slack "a"



Drive chain slack (Maintenance Stand)
50.0–60.0 mm (1.97–2.36 in)

Refer to "DRIVE CHAIN SLACK" on page 3-22.

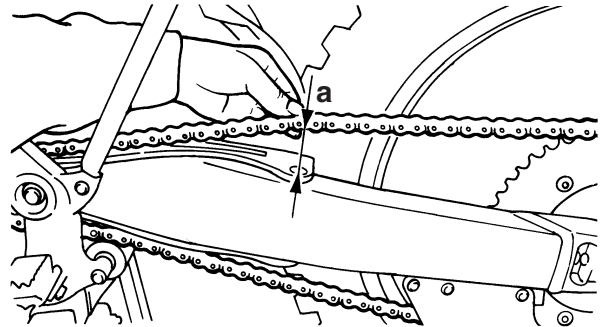

6. Tighten:

- Rear wheel axle nut "1"



Wheel axle nut
125 N·m (12.5 kgf·m, 92 lb·ft)

- Locknut "2"



Locknut
21 N·m (2.1 kgf·m, 15 lb·ft)

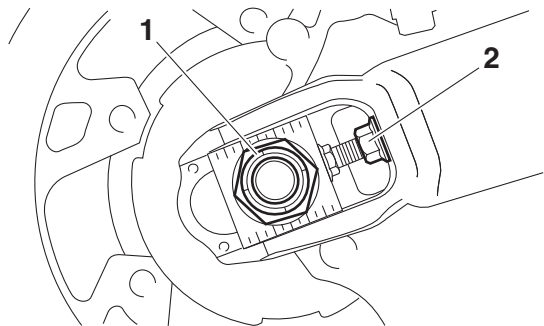

EAM20097

FRONT BRAKE

EAM30519

REPLACING THE FRONT BRAKE PADS

TIP

When replacing the brake pads, it is not necessary to disconnect the brake hose or disassemble the brake caliper.

1. Remove:

- Brake pad
 - a. Remove the pad pin plug "1".

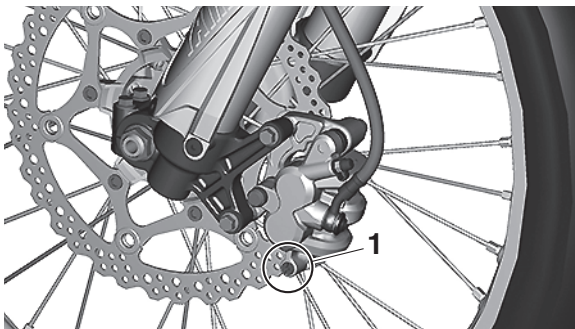

- b. Loosen the pad pin "2".
- c. Remove the brake caliper "3" from the front fork.

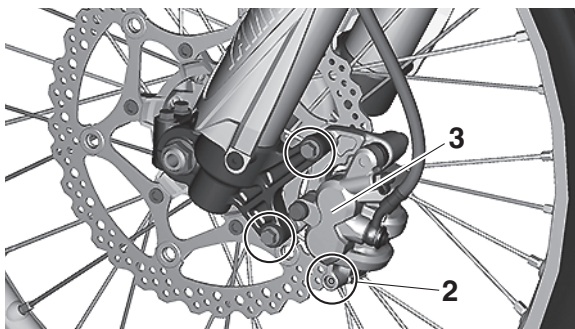

- d. Remove the pad pin and brake pads "4".

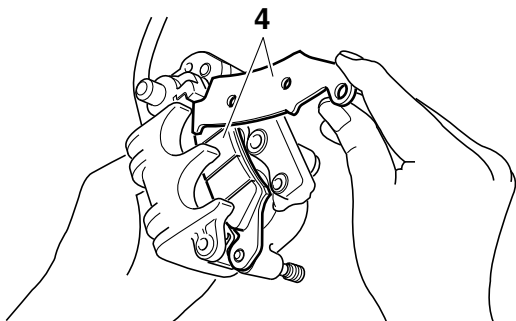

2. Measure:

- Brake pad wear limit "a"
Out of specification → Replace the brake pads as a set.



**Brake pad lining thickness limit
1.0 mm (0.04 in)**

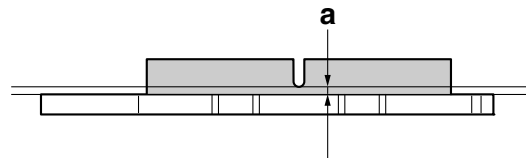

3. Install:

- Brake pad
 - a. Connect the plastic hose "1" to the bleed screw "2" and place a container under the end of the plastic hose.

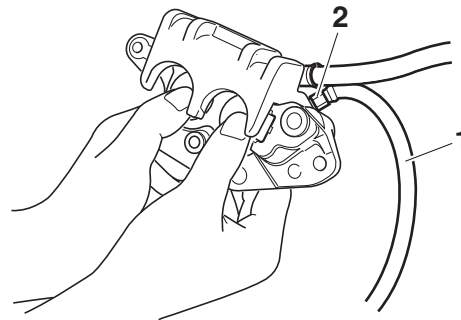

- b. Loosen the bleed screw and push the brake caliper piston in.

EWA19160

⚠ WARNING

Do not reuse the drained brake fluid.

- c. Tighten the bleed screw.



**Bleed screw
5 N·m (0.5 kgf·m, 3.7 lb·ft)**

- d. Install the brake pads "3" and the pad pin.

TIP

- Install the brake pads with their projections "a" into the brake caliper recesses "b".
- Temporarily tighten the pad pin at this point.

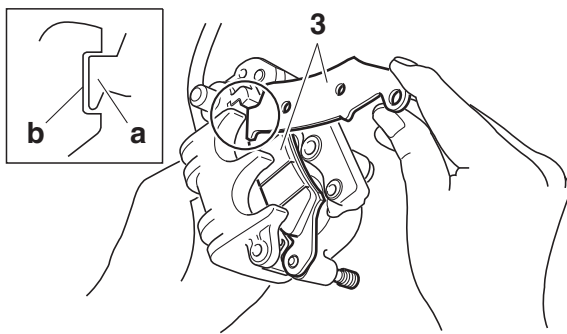

e. Install the brake caliper “4” and tighten the pad pin “5”.

| | |
|---|---|
|  | Bolt (brake caliper) 28 N·m (2.8 kgf·m, 21 lb·ft) |
| | Pad pin 17 N·m (1.7 kgf·m, 13 lb·ft) |

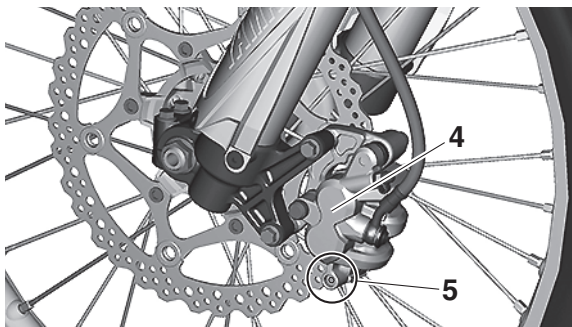

f. Install the pad pin plug “6”.

| | |
|---|--|
|  | Pad pin plug 2.5 N·m (0.25 kgf·m, 1.8 lb·ft) |
|---|--|

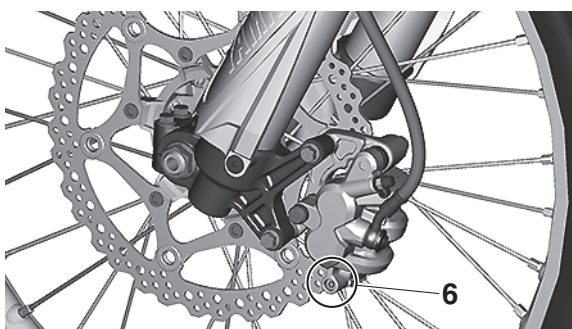

4. Check:
- Brake fluid level
Refer to “CHECKING THE BRAKE FLUID LEVEL” on page 3-19.
5. Check:
- Brake lever operation
A softy or spongy feeling → Bleed the brake system.
Refer to “BLEEDING THE HYDRAULIC BRAKE SYSTEM” on page 3-21.

EAM20098

REAR BRAKE

EAM30523

REPLACING THE REAR BRAKE PADS

TIP

When replacing the brake pads, it is not necessary to disconnect the brake hose or disassemble the brake caliper.

1. Remove:

- Brake pad
 - a. Remove the protector "1" and the pad pin plug "2".

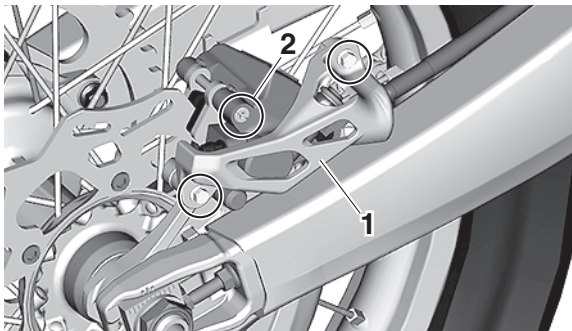

- b. Loosen the pad pin "3".
- c. Remove the rear wheel "4" and the brake caliper "5".

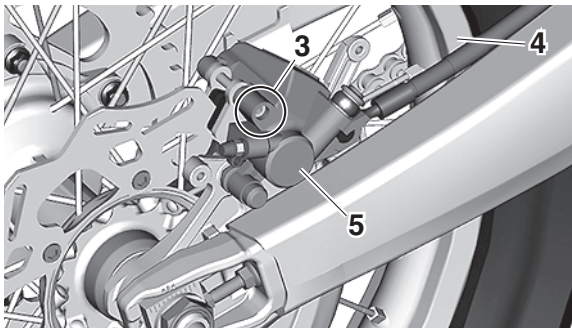

- d. Remove the pad pin "6" and the brake pads "7".

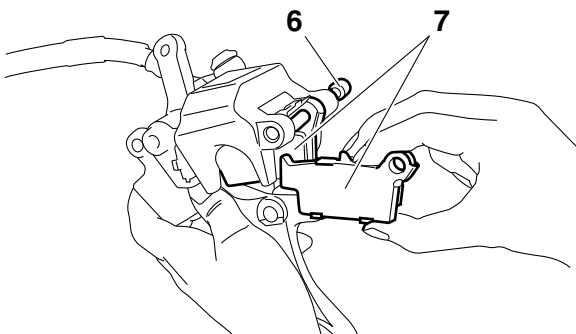

2. Measure:

- Brake pad wear limit "a"
Out of specification → Replace the brake pads as a set.



**Brake pad lining thickness limit
1.0 mm (0.04 in)**



3. Install:

- Brake pad
 - a. Connect the plastic hose "1" to the bleed screw "2" and place a container under the end of the plastic hose.

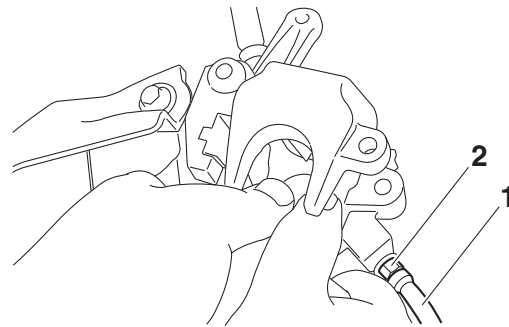

- b. Loosen the bleed screw and push the brake caliper piston in.

EWA19170

WARNING

Do not reuse the drained brake fluid.

- c. Tighten the bleed screw.



**Bleed screw
5 N·m (0.5 kgf·m, 3.7 lb·ft)**

- d. Install the brake pads "3" and the pad pin "4".

TIP

- Install the brake pads with their projections "a" into the brake caliper recesses "b".
- Temporarily tighten the pad pin at this point.

REAR BRAKE

Refer to “BLEEDING THE HYDRAULIC BRAKE SYSTEM” on page 3-21.

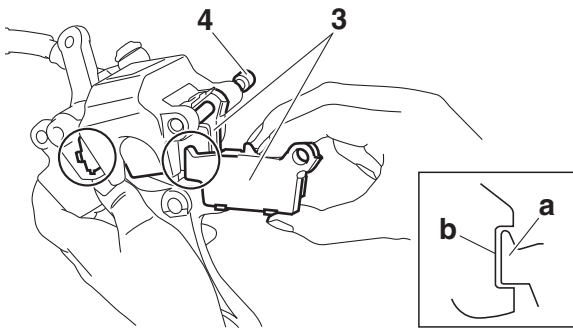

- e. Install the brake caliper “5” and the rear wheel “6”.
- f. Tighten the pad pin “7”.



Pad pin
17 N·m (1.7 kgf·m, 13 lb·ft)

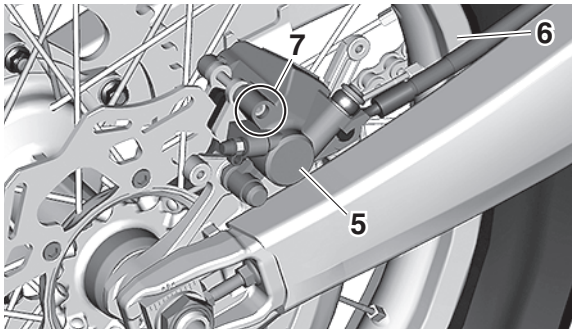

- g. Install the pad pin plug “8” and the protector “9”.



Pad pin plug
2.5 N·m (0.25 kgf·m, 1.8 lb·ft)
Bolt (protector)
7 N·m (0.7 kgf·m, 5.2 lb·ft)

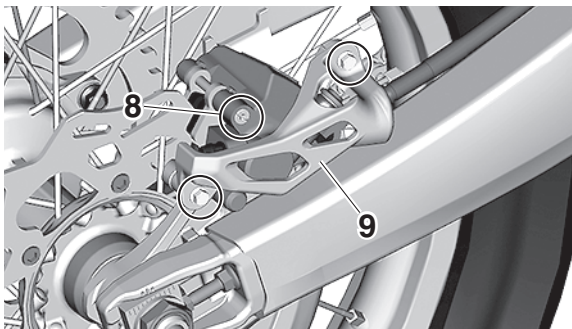

4. Check:
 - Brake fluid level
Refer to “CHECKING THE BRAKE FLUID LEVEL” on page 3-19.
5. Check:
 - Brake pedal operation
A softy or spongy feeling → Bleed the brake system.

EAM20099

HANDLEBAR

EAM30052

REMOVING THE HANDLEBAR

1. Stand the vehicle upright on a level surface.

EWA13120

WARNING

Securely support the vehicle so that there is no danger of it falling over.

2. Remove:

- Clutch switch "1"

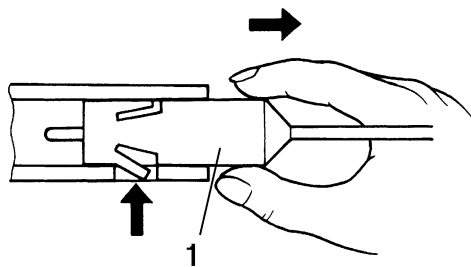

TIP

Press the projection, and remove it from the clutch lever assembly.

3. Remove:

- Grip "1"

TIP

Blow in compressed air between the handlebar or tube guide and the grip. Then remove the grip which has become loose.

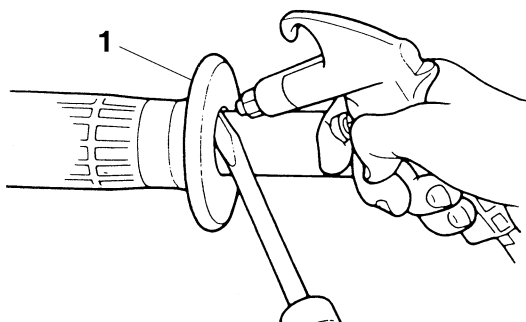

4. Remove:

- Throttle cable housing "1"
- Throttle grip "2"

TIP

While removing the throttle cable housing, pull back the rubber cover "3".

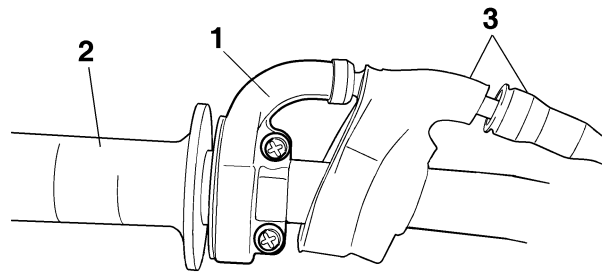

EAM30053

CHECKING THE HANDLEBAR

1. Check:

- Handlebar
Bends/cracks/damage → Replace.

EWA13690

WARNING

Do not attempt to straighten a bent handlebar as this may dangerously weaken it.

EAM30054

INSTALLING THE HANDLEBAR

1. Stand the vehicle upright on a level surface.

EWA13120

WARNING

Securely support the vehicle so that there is no danger of it falling over.

2. Install:

- Damper "1"
- Lower handlebar holder "2" (temporarily)
- Handlebar "3"
- Upper handlebar holder "4"



**Upper handlebar holder bolt
28 N·m (2.8 kgf·m, 21 lb·ft)**

TIP

- Install the lower handlebar holders with them side having the greater distance "a" from the mounting bolt center facing forward.
- Installing the lower handlebar holders in the reverse direction allow the front-to-rear offset amount of the handlebar position to be changed.
- The upper handlebar holders should be installed with the punch marks "b" facing forward.
- When installing the handlebar, make sure that right and left marks "c" are in place identically on both sides.
- Install the handlebar so that the projection "d" of the upper handlebar holders is positioned at the mark on the handlebar as shown.

HANDLEBAR

ECA14250

NOTICE

- First, tighten the bolts on the front side of the handlebar holder, and then on the rear side.
- Turn the handlebar all the way to the left and right. If there is any contact with the fuel tank, adjust the handlebar position.

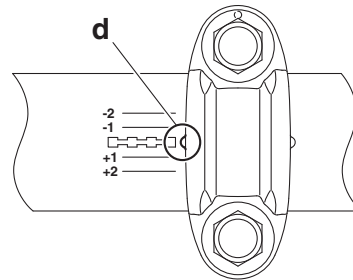
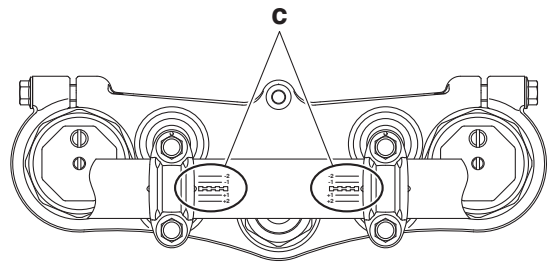
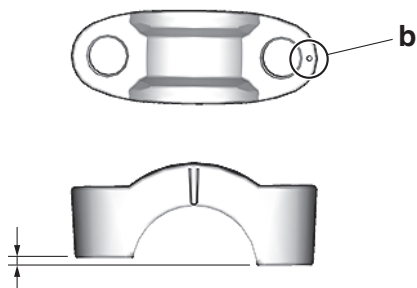
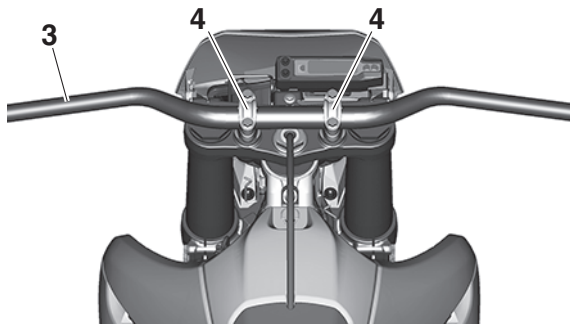
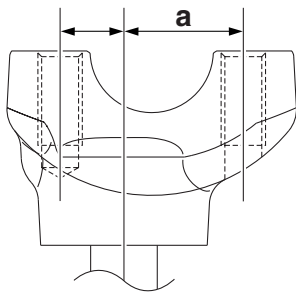
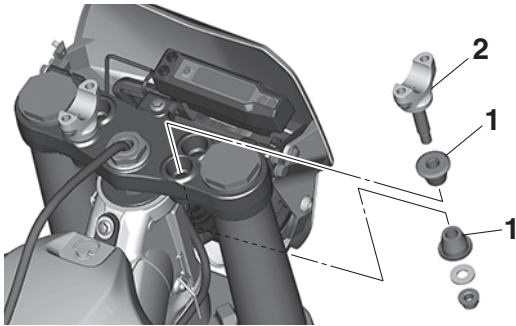

3. Tighten:

- Lower handlebar holder nut



Lower handlebar holder nut
40 N·m (4.0 kgf·m, 30 lb-ft)

4. Install:

- Clutch lever holder "1"
- Clutch lever "2"



Clutch lever holder bolt
3.8 N·m (0.38 kgf·m, 2.8 lb-ft)
Clutch lever nut
4.0 N·m (0.40 kgf·m, 3.0 lb-ft)

TIP

The clutch lever holder "1" should be installed according to the dimensions shown.

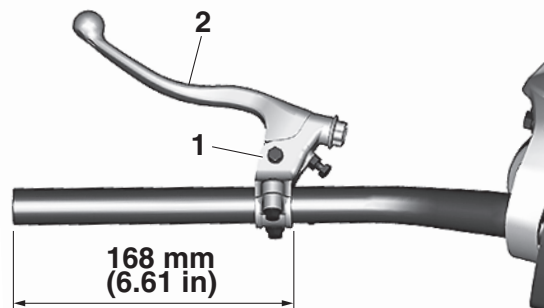

5. Install:

- Engine stop switch "1"
- Mode switch "2" (Except for Canada)
- Clamp "3"



Engine stop switch screw
 0.5 N·m (0.05 kgf·m, 0.37 lb·ft)
Screw (mode switch)
 1.3 N·m (0.13 kgf·m, 0.95 lb·ft)

TIP

- The engine stop switch “1” and the mode switch “2” should be installed according to the dimensions shown.
- Pass the engine stop switch lead through the middle of the clutch lever holder.

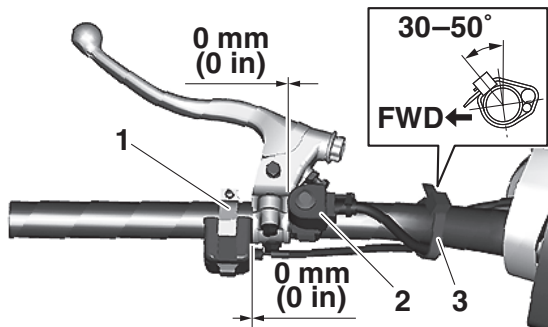

6. Install:

- Handlebar grip “1”
 - Slightly coat the handlebar left end with a rubber adhesive.
 - Install the handlebar grip on the handlebar by pressing the grip from the left side.
 - Wipe off any excess adhesive with a clean cloth.

TIP

Install the handlebar grip to the handlebar so that the line “a” between the two arrow marks faces straight upward.

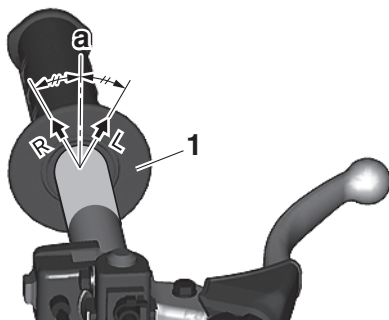

7. Install:

- Clutch cable “1”

TIP

Before installation, apply the lithium-soap-based grease to the clutch cable end.

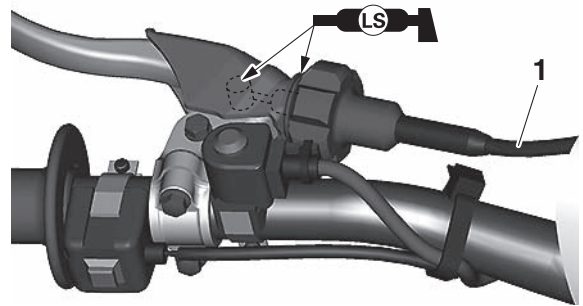

8. Adjust:

- Clutch lever free play
 Refer to “ADJUSTING THE CLUTCH LEVER FREE PLAY” on page 3-12.



Clutch lever free play
 7.0–12.0 mm (0.28–0.47 in)

9. Install:

- Right grip “1”
- Collar “2”
- Apply adhesive to the tube guide “3”.

TIP

- Before applying the adhesive, wipe off grease or oil on the tube guide surface “a” with a lacquer thinner.
- Install the grip to the tube guide so that the grip match mark “b” and tube guide slot “c” form the angle as shown.

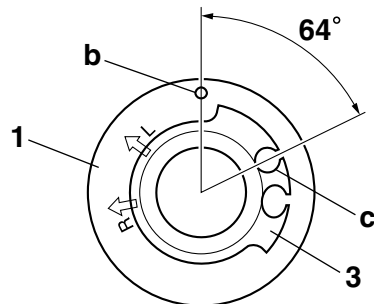
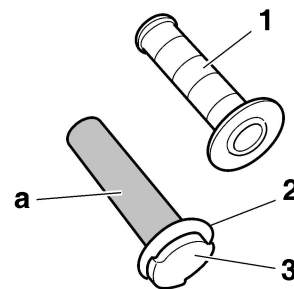

10. Install:

- Rubber cover “1”
- Throttle grip “2”

TIP

Apply the lithium-soap-based grease on the throttle grip sliding surface.

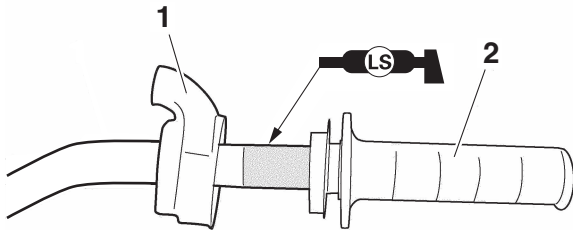

11. Install:

- Throttle cable "1"

TIP

Slightly coat the end of throttle cable and inside of throttle grip with lithium-soap-based grease. Then, mount the throttle grip onto the handlebar.

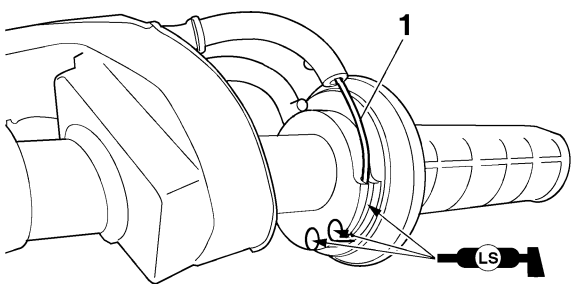

12. Install:

- Throttle cable housing "1"
- Screw (throttle cable housing) "2"



Screw (throttle cable housing)
3.8 N·m (0.38 kgf·m, 2.8 lb·ft)

EWA19310

WARNING

After tightening the throttle cable housing screws, check that the throttle grip "3" moves smoothly. If it does not, retighten the screws for adjustment.

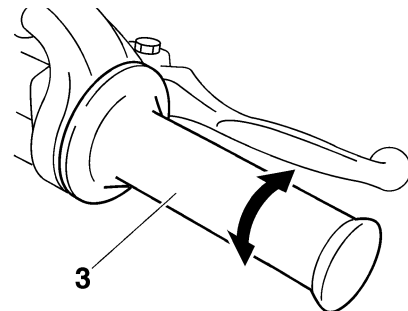
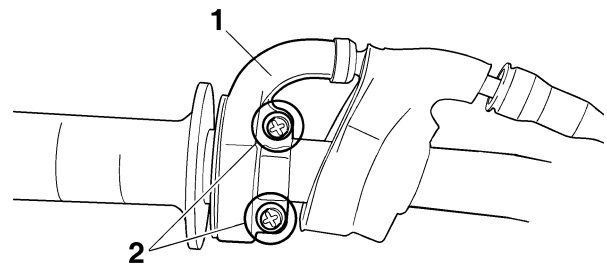

13. Install:

- Rubber cover "1"
- Cover (throttle cable housing) "2"

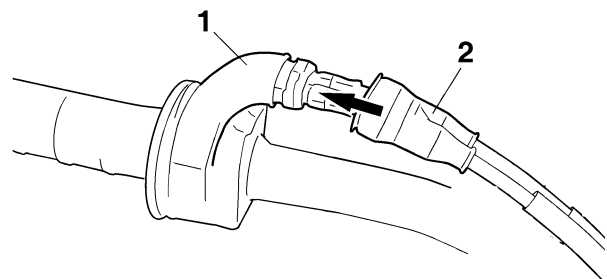

14. Install:

- Start switch "1"
- Front brake master cylinder assembly "2"
- Front brake master cylinder holder "3"
- Front brake master cylinder holder bolt "4"
- Clamp "5"



Front brake master cylinder holder bolt
9 N·m (0.9 kgf·m, 6.6 lb·ft)

TIP

- Install the brake master cylinder holder with the "UP" mark facing up.
- Install in order for the top of the front brake master cylinder assembly to be level.
- First, tighten the upper bolt, then the lower bolt.

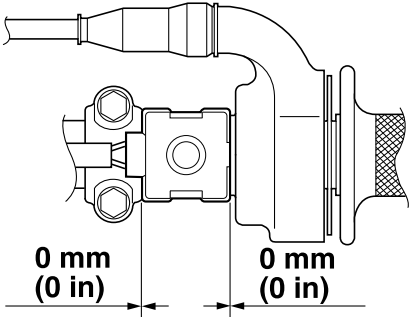
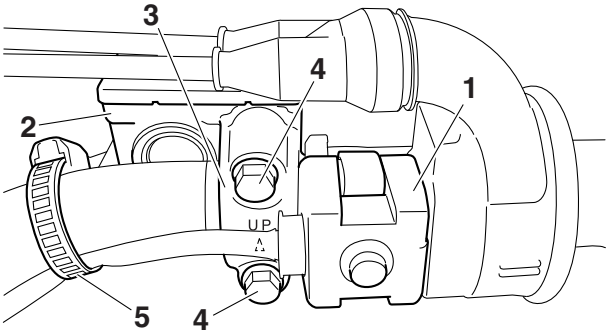

15.Adjust:

- Throttle grip free play
Refer to "CHECKING THE THROTTLE GRIP" on page 3-8.

| | |
|---|--|
|  | <p>Throttle grip free play 3.0–6.0 mm (0.12–0.24 in)</p> |
|---|--|

EAM20100

FRONT FORK

EAM30055

REMOVING THE FRONT FORK LEGS

1. Use a maintenance stand to raise the front wheel off the ground.

EWA13120

WARNING

Securely support the vehicle so that there is no danger of it falling over.

TIP

Record the adjusting screw setting position before loosening the adjuster and the base valve.

2. Loosen:

- Upper bracket pinch bolt
- Damper assembly
- Lower bracket pinch bolt

EWA20350

WARNING

Before loosening the upper and lower bracket pinch bolts, support the front fork leg.

TIP

Before removing the front fork leg from the vehicle, loosen the damper assembly "1" with the cap bolt ring wrench "2".



Cap bolt ring wrench
90890-01501
Cap bolt ring wrench
YM-01501

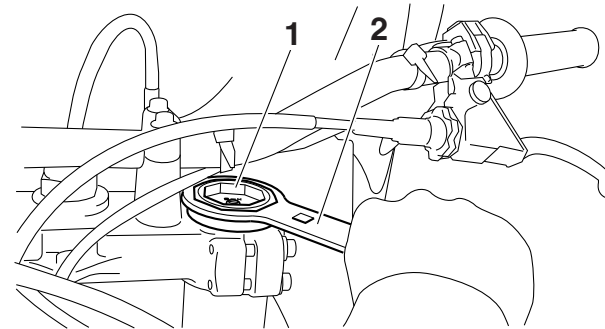

3. Remove:

- Front fork leg

EAM30056

DISASSEMBLING THE FRONT FORK LEGS

1. Drain:

- Fork oil

2. Remove:

- Adjuster "1"
(from the inner tube)

TIP

- While compressing the inner tube "2", set the cap bolt ring wrench "4" between the inner tube and locknut "3".
- Hold the locknut and remove the adjuster.

ECA24520

NOTICE

Do not remove the locknut as the damper rod may go into the damper assembly and not be taken out.



Cap bolt ring wrench
90890-01501
Cap bolt ring wrench
YM-01501

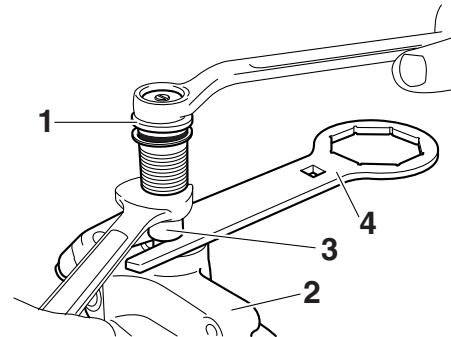

3. Remove:

- Dust seal "1"
- Stopper ring "2"
(with a flat-head screwdriver)

ECA14180

NOTICE

Do not scratch the inner tube.

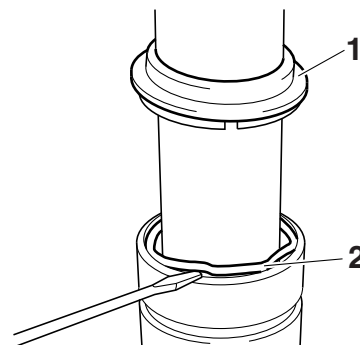

4. Remove:

- Inner tube "1"
 - a. Push in slowly "a" the inner tube just before it bottoms out and then pull it back quickly "b".
 - b. Repeat this step until the inner tube can be pulled out from the outer tube.

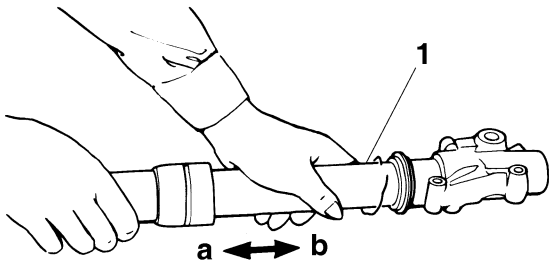

5. Remove:
- Base valve “1”
(from the damper assembly)

TIP

Hold the damper assembly with the cap bolt ring wrench “2” and use the cap bolt wrench “3” to remove the base valve.



**Cap bolt wrench
90890-01500**
**Cap bolt wrench
YM-01500**
**Cap bolt ring wrench
90890-01501**
**Cap bolt ring wrench
YM-01501**

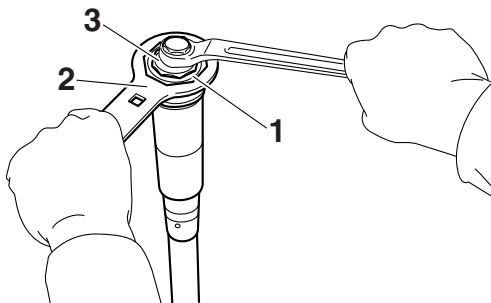

EAM30057

CHECKING THE FRONT FORK LEGS

1. Check:
- Inner tube surface
Scratches → Repair or replace.
Use #1000 grit wet sandpaper.
Damaged oil lock piece → Replace.
 - Inner tube bends
Out of specification → Replace.
Use the dial gauge.



**Inner tube bending limit
0.2 mm (0.01 in)**

TIP

The bending value is shown by one half of the

dial gauge reading.

EWA13650

WARNING

Do not attempt to straighten a bent inner tube as this may dangerously weaken it.

2. Check:
- Outer tube
Scratches/wear/damage → Replace.
3. Measure:
- Fork spring free length “a”
Out of specification → Replace.



**Fork spring free length limit
492.0 mm (19.37 in)**

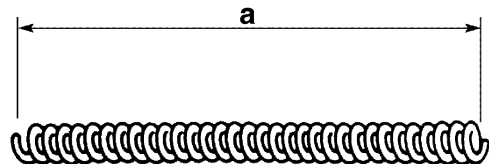

4. Check:
- Damper assembly “1”
Bend/damage → Replace.
 - O-ring “2”
Wear/damage → Replace.

ECA14200

NOTICE

- The front fork leg has a built-in damper adjusting rod and a very sophisticated internal construction, which are particularly sensitive to foreign material.
- When disassembling and assembling the front fork leg, do not allow any foreign material to enter the front fork.

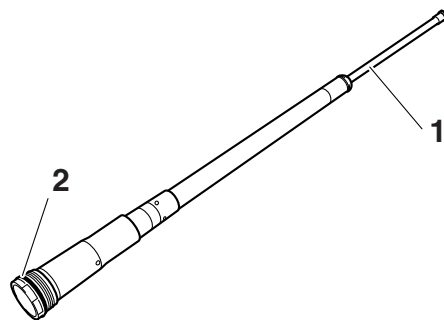

5. Check:
- Base valve “1”
Wear/damage → Replace.

FRONT FORK

- Contamination → Clean.
- O-ring “2”
Wear/damage → Replace.
- Base valve bushing
Wear/damage → Replace.
- Fork spring “3”
Damage/fatigue → Replace the base valve.
- Bleed screw “4”
Wear/damage → Replace.

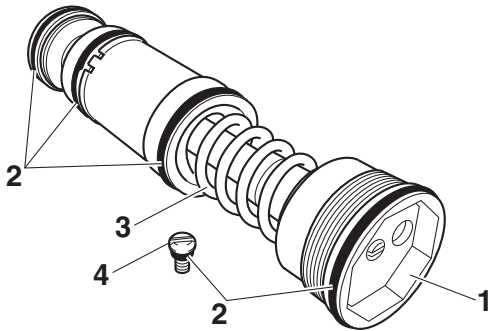

6. Check:

- Upper spring seat “1”
(contacting surface “a”)
Wear/damage → Replace.

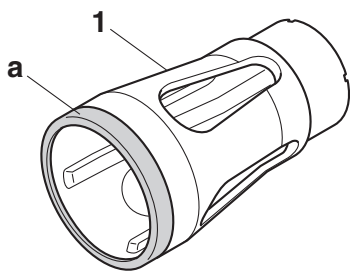

7. Check:

- Adjuster “1”
- O-ring “2”
Wear/damage → Replace.

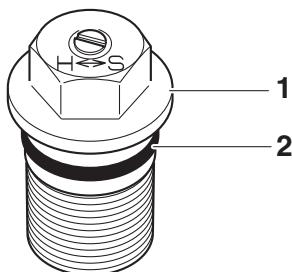

8. Check:

- Scraper “1”
Damage → Replace.

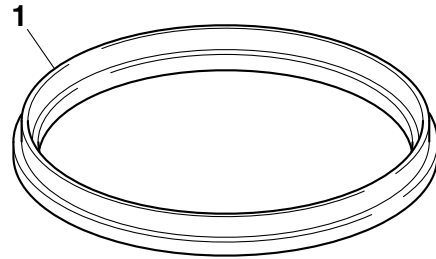

EAM30058

ASSEMBLING THE FRONT FORK LEGS

EWA13660

⚠ WARNING

- Make sure the oil levels in both front fork legs are equal.
- Uneven oil levels can result in poor handling and a loss of stability.

TIP

- When assembling the front fork leg, be sure to replace the following parts:
 - Inner tube bushing
 - Slide metal
 - Oil seal
 - Copper washer
- Before assembling the front fork leg, make sure that all of the components are clean.

1. Stretch the damper assembly fully.
2. Fill:
 - Damper assembly



Recommended oil
Yamaha Suspension Oil S1
Standard oil amount
216 cm³ (7.30 US oz, 7.62 Imp.oz)

ECA24530

NOTICE

- Be sure to use the recommended oil. Other oils may have an adverse effect on front fork performance.
- When disassembling and assembling the front fork leg, take care not to allow any foreign material to enter the front fork.

3. After filling, pump the damper assembly “1” slowly up and down (about 200 mm (7.9 in) stroke) several times to bleed the damper assembly of air.

TIP

Avoid excessive full stroke. A stroke of 200 mm (7.9 in) or more will cause air to enter. In this case, repeat the steps (1) to (3).

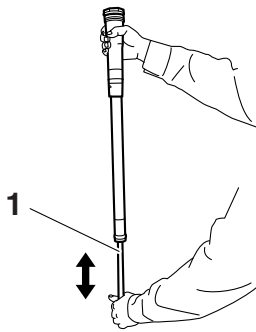

4. Measure:

- Oil level (left and right) "a"
Out of specification → Regulate.



Standard oil level
145–148 mm (5.71–5.83 in)
From top of fully stretched damper assembly.

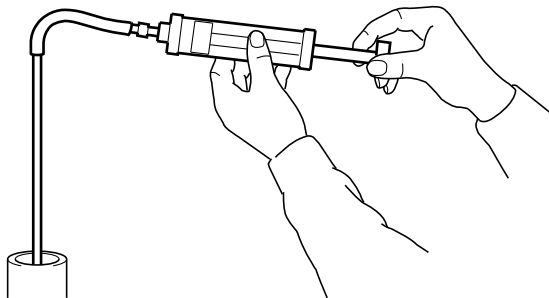
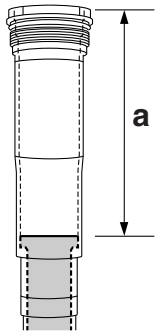

5. Tighten:

- Locknut "1"

TIP

Fully finger tighten the locknut onto the damper assembly.

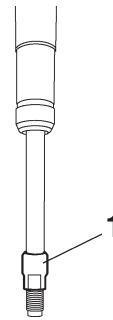

6. Loosen:

- Compression damping force adjuster "1"

TIP

- Before loosening the damping force adjuster, record the setting position.
- Unless the damping force adjuster is fully loosened, correct damping characteristic cannot be obtained after installation.

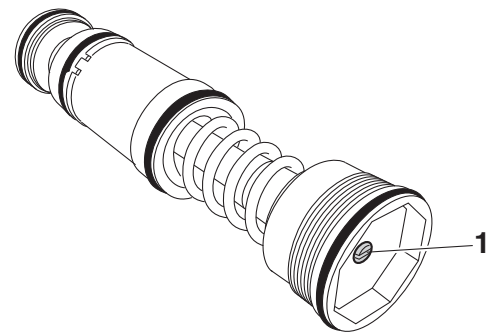

7. Install:

- Base valve "1"
(to the damper assembly "2")

TIP

First bring the damper rod pressure to a maximum. Then install the base valve while releasing the damper rod pressure.

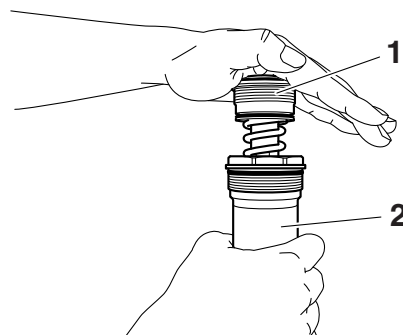

8. Check:

- Damper assembly
Not fully stretched → Repeat the steps (1) to (7).

9. Tighten:

- Base valve "1"



Base valve
28 N·m (2.8 kgf·m, 21 lb·ft)

TIP

Hold the damper assembly with the cap bolt ring wrench “2” and use the cap bolt wrench “3” to tighten the base valve.



Cap bolt wrench
90890-01500
Cap bolt wrench
YM-01500
Cap bolt ring wrench
90890-01501
Cap bolt ring wrench
YM-01501

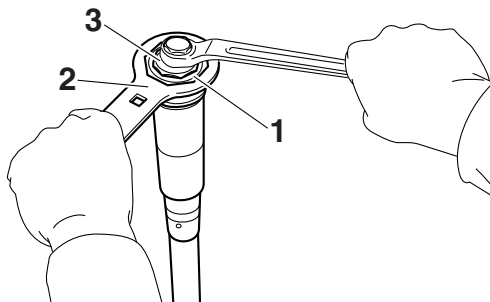

10. After filling, pump the damper assembly “1” slowly up and down more than 10 times to distribute the fork oil.

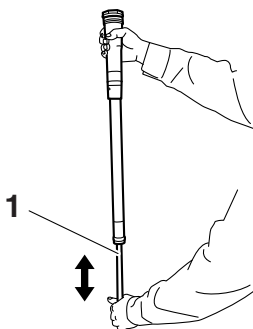

11. While protecting the damper assembly “1” with a cloth and compressing fully, allow excessive oil to overflow on the base valve side.

ECA24540

NOTICE

Take care not to damage the damper assembly.

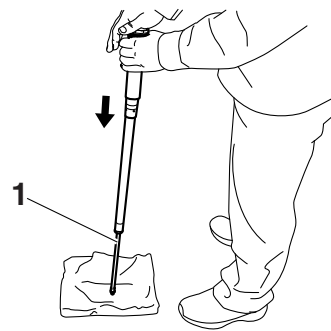

12. Allow the overflowing oil to escape at the hole “a” in the damper assembly.

TIP

The overflow measures about 10 cm³ (0.34 US oz, 0.35 Imp.oz).

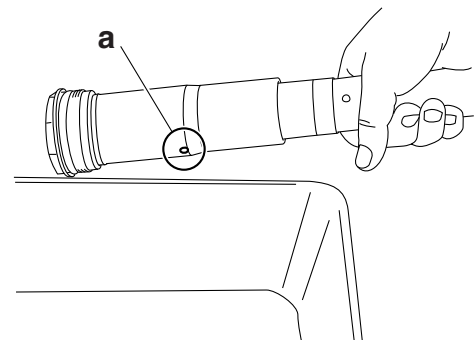

13. Check:

- Damper assembly smooth movement
- Tightness/binding/rough spots → Repeat the steps (1) to (12).

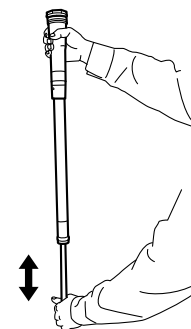

14. Install:

- Dust seal “1” **New**
- Scraper “2”
- Stopper ring “3”
- Oil seal “4” **New**
- Washer “5”
- Slide metal “6” **New**
(to the inner tube “7”)

ECA24550

NOTICE

Make sure that the numbered side of the oil seal faces bottom side.

FRONT FORK

TIP

- Apply the lithium-soap-based grease on the dust seal lip and oil seal lip.
- Apply the fork oil on the inner tube.
- Install the scraper to the inner tube as shown in the illustration.
- When installing the oil seal, use vinyl seat “a” with fork oil applied to protect the oil seal lip.

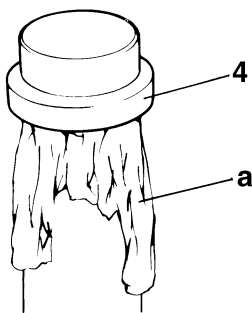
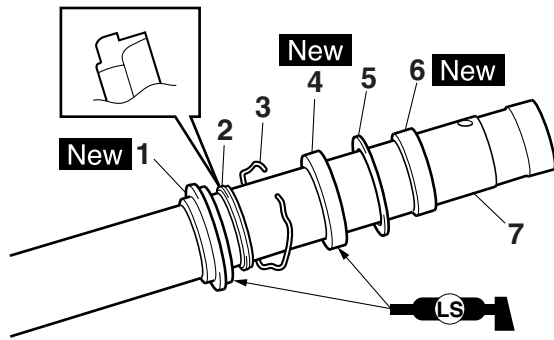

15. Install:

- Piston metal “1” **New**

TIP

Install the piston metal onto the slot on inner tube.

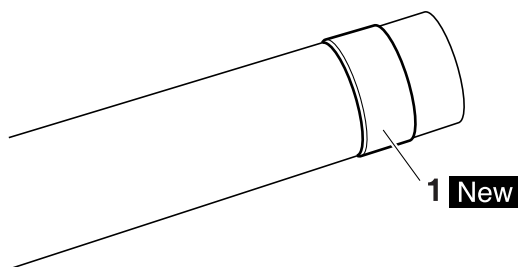

16. Install:

- Outer tube “1”
(to the inner tube “2”)

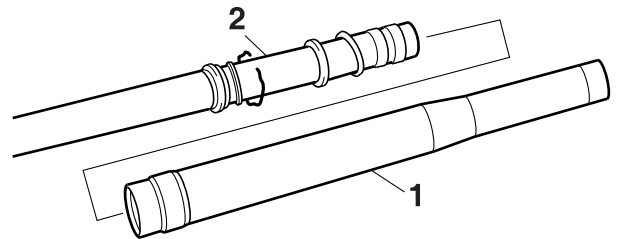

17. Install:

- Slide metal “1” **New**
- Washer “2”
(to the outer tube)

TIP

Press the slide metal into the outer tube with fork seal driver “3”.



Fork seal driver
90890-01502
Fork seal driver (48)
YM-A0948

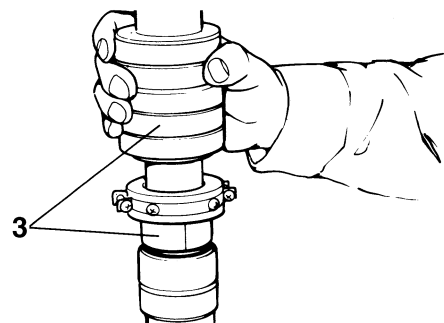
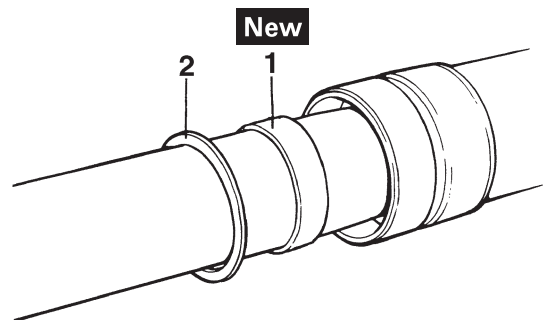

18. Install:

- Oil seal “1” **New**

TIP

Using a fork seal driver “2”, press the oil seal in until the stopper ring groove fully appears.

FRONT FORK



Fork seal driver
90890-01502
Fork seal driver (48)
YM-A0948

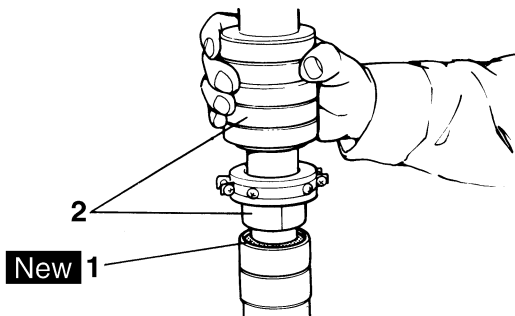

19. Install:
- Stopper ring "1"

TIP
Fit the stopper ring correctly in the groove in the outer tube.

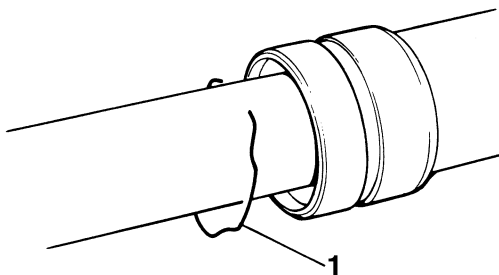

20. Install:
- Scraper "1"
 - Dust seal "2" **New**

TIP
Apply lithium-soap-based grease on the inner tube.

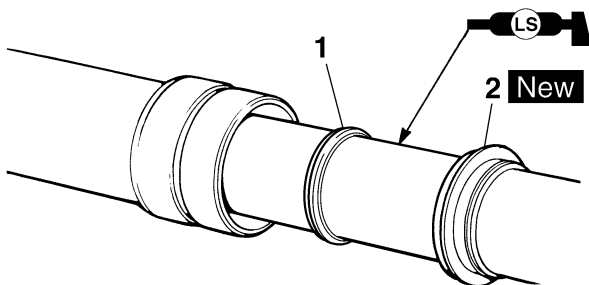

21. Check:
- Inner tube smooth movement
- Tightness/binding/rough spots → Repeat the steps (14) to (20).

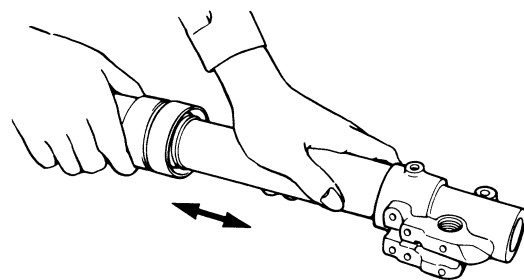

22. Measure:
- Distance "a"
- Out of specification → Turn the locknut to specification.



Distance "a"
16 mm (0.63 in) or more
Between the damper assembly
"1" bottom and locknut "2" bot-
tom.

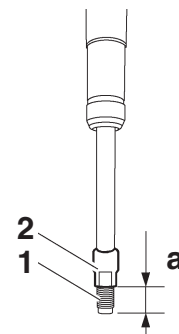

23. Install:
- Upper spring seat "1"
 - Fork spring "2"
- (to the damper assembly "3")

TIP
Install the upper spring seat with its larger dia. end "a" facing the fork spring.

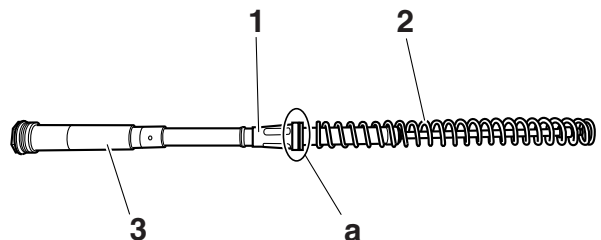

24. Install:
- Damper assembly "1"
- (to the inner tube "2")

ECA24560

NOTICE

Allow the damper assembly to slide slowly down the inner tube until it contacts the bottom of the inner tube. Be careful not to damage the inner tube.

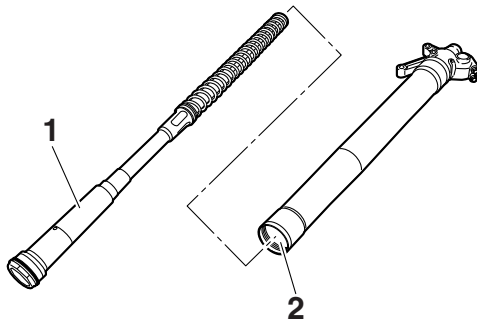

25. Loosen:

- Rebound damping force adjuster "1"

TIP

- Before loosening the damping force adjuster, record the setting position.
- Unless the damping force adjuster is fully loosened, correct damping characteristic cannot be obtained after installation.

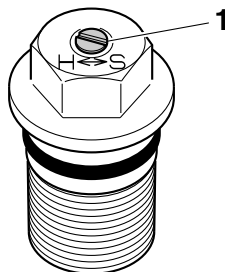

26. Install:

- Damper adjusting rod "1"
 - Copper washer "2" **New**
 - Adjuster "3"
- (to the damper assembly "4")

TIP

- While compressing the inner tube "5", set the cap bolt ring wrench "7" between the inner tube and locknut "6".
- Fully finger tighten the adjuster onto the damper assembly.



Cap bolt ring wrench
90890-01501
Cap bolt ring wrench
YM-01501

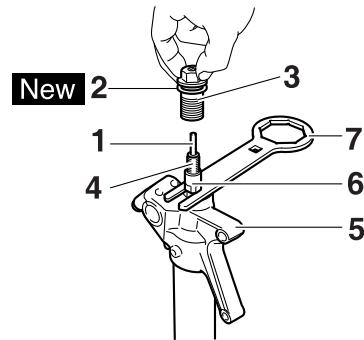

27. Measure:

- Gap "a" between the adjuster "1" and the locknut "2"
- Out of specification → Retighten and readjust the locknut.



Gap "a" between the adjuster and the locknut
0.5–1.0 mm (0.02–0.04 in)

TIP

If it is installed with a gap out of specification, correct damping force cannot be obtained.

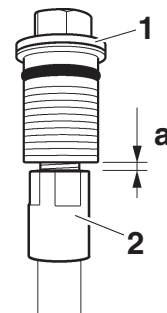

28. Tighten:

- Adjuster (damper assembly) "1"



Adjuster (damper assembly)
29 N·m (2.9 kgf·m, 21 lb-ft)

TIP

Hold the locknut "2" and tighten the adjuster.

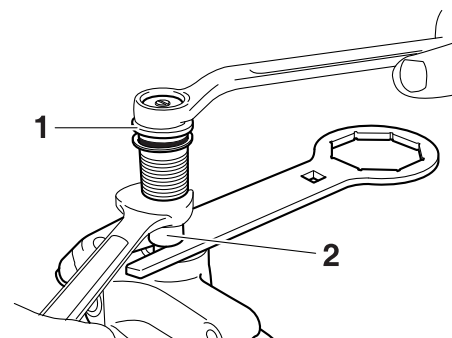

FRONT FORK

29. Install:

- Adjuster "1"
(to the inner tube)



Adjuster
55 N·m (5.5 kgf·m, 41 lb·ft)
LOCTITE®

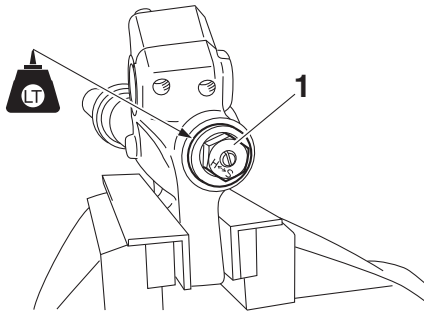

30. Fill:

- Front fork leg



Recommended oil
Yamaha Suspension Oil S1
Standard oil amount
285 cm³ (9.64 US oz, 10.05 Imp. oz)
Extent of adjustment
260–365 cm³ (8.79–12.34 US oz, 9.17–12.87 Imp. oz)

ECA24570

NOTICE

- Be sure to use the recommended oil. Other oils may have an adverse effect on front fork performance.
- When disassembling and assembling the front fork leg, do not allow any foreign material to enter the front fork.

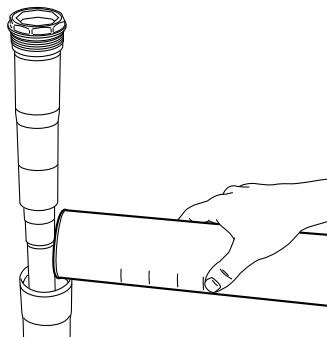

31. Install:

- Damper assembly "1"
(to the outer tube)

TIP

Temporarily tighten the damper assembly.

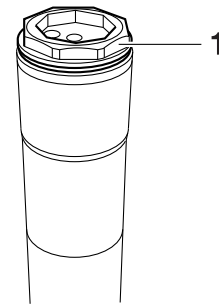

32. Install:

- Protector guide "1"

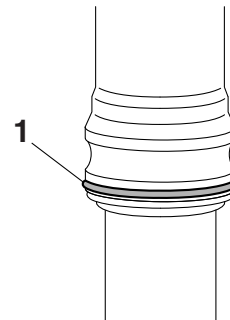

EAM30059

INSTALLING THE FRONT FORK LEGS

1. Install:

- Front fork "1"

TIP

- Temporarily tighten the lower bracket pinch bolts.
- Do not tighten the upper bracket pinch bolts yet.

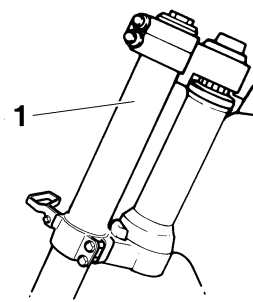

2. Tighten:

- Damper assembly "1"



Damper assembly
30 N·m (3.0 kgf·m, 22 lb·ft)

TIP

Use the cap bolt ring wrench "2" to tighten the damper assembly.

FRONT FORK



Cap bolt ring wrench
90890-01501
Cap bolt ring wrench
YM-01501

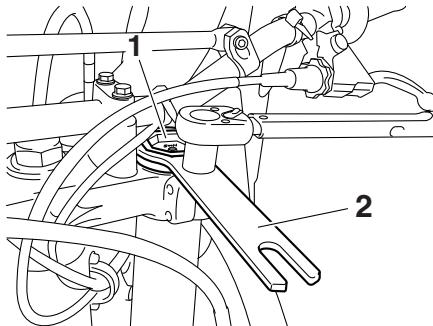

3. Adjust:

- Front fork top end "a"



Front fork top end (standard) "a"
5 mm (0.20 in)

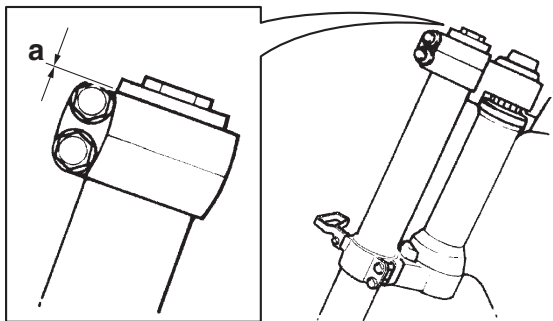

4. Tighten:

- Upper bracket pinch bolt "1"



Upper bracket pinch bolt
21 N·m (2.1 kgf·m, 15 lb-ft)

- Lower bracket pinch bolt "2"



Lower bracket pinch bolt
21 N·m (2.1 kgf·m, 15 lb-ft)

EWA19320

WARNING

Tighten the lower bracket to specified torque. If torqued too much, it may cause the front fork to malfunction.

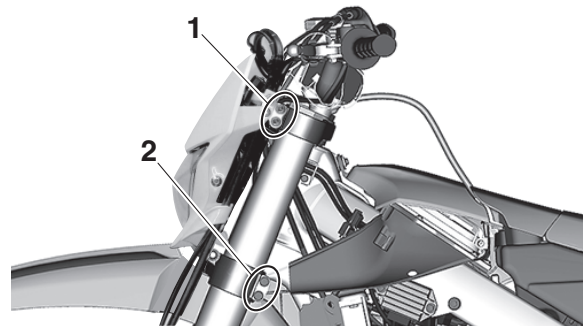

5. Install:

- Speed sensor lead "1"
- Front brake hose "2"
- Plate "3"
(to the left front fork protector)



Plate bolt
3.8 N·m (0.38 kgf·m, 2.8 lb-ft)

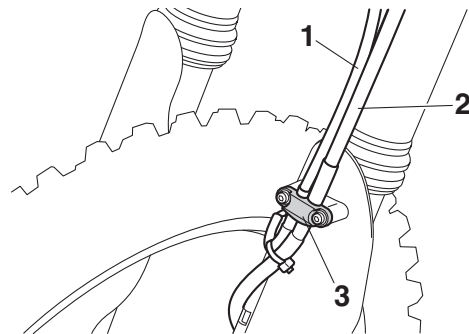

6. Install:

- Protector "1"
- Bolt (protector) "2"



Bolt (protector)
5 N·m (0.5 kgf·m, 3.7 lb-ft)

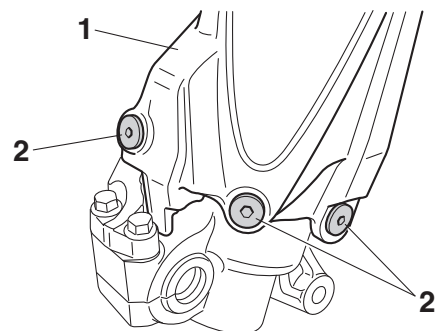

7. Adjust:

- Rebound damping force

TIP

Turn in the damping adjuster "1" finger-tight and then turn out to the originally set position.

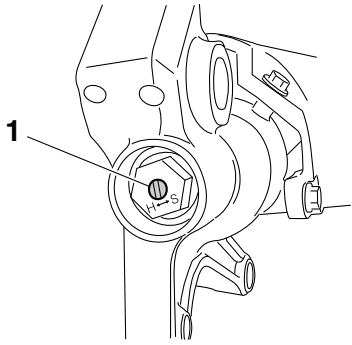

8. Adjust:

- Compression damping force

TIP

Turn in the damping adjuster "1" finger-tight and then turn out to the originally set position.

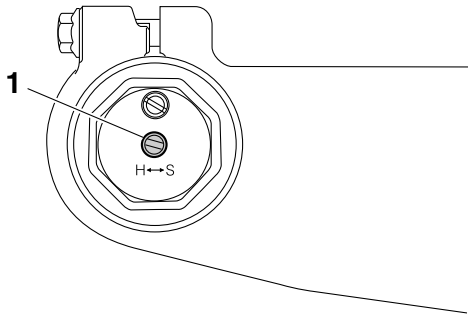

EAM20101

STEERING HEAD

EAM30060

REMOVING THE LOWER BRACKET

1. Use a maintenance stand to raise the front wheel off the ground.

EWA13120

WARNING

Securely support the vehicle so that there is no danger of it falling over.

2. Remove:
 - Ring nut "1"

TIP

Remove the ring nut with the steering nut wrench "2".



Steering nut wrench
90890-01403
Exhaust flange nut wrench
YU-A9472

EWA13730

WARNING

Securely support the lower bracket so that there is no danger of it falling.

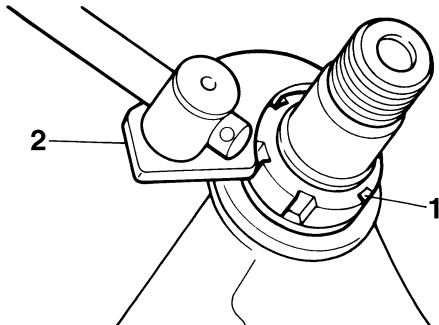

EAM30061

CHECKING THE STEERING HEAD

1. Wash with kerosene:
 - Bearing
 - Bearing race
2. Check:
 - Bearing
 - Bearing race

Damage/pitting → Replace.
3. Replace:
 - Bearing
 - Bearing race
 - a. Remove the bearing race from the steering head pipe with a long rod "1" and a hammer.
 - b. Remove the bearing race from the lower bracket with a chisel "2" and a hammer.

- c. Install a new bearing race.

ECA14270

NOTICE

If the bearing race is not installed properly, the steering head pipe could be damaged.

TIP

Always replace the bearing and the bearing race as a set.

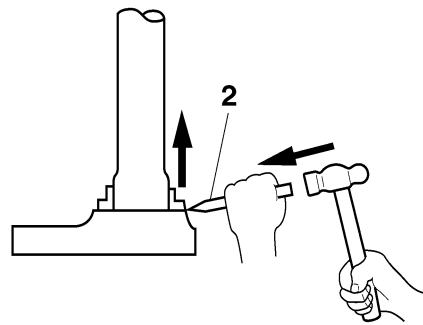
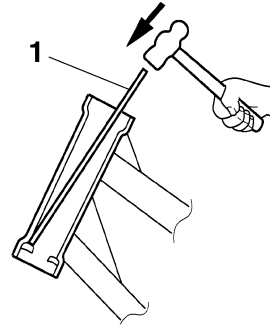

4. Check:
 - Upper bracket
 - Lower bracket

(along with the steering stem)
Bends/cracks/damage → Replace.

EAM30062

INSTALLING THE STEERING HEAD

1. Install:
 - Lower bearing "1"

TIP

Apply the lithium-soap-based grease on the dust seal lip and bearing inner circumference.

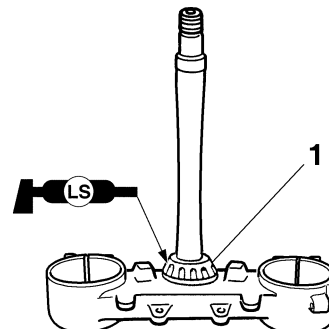

STEERING HEAD

2. Install:

- Bearing race
- Upper bearing "1"
- Bearing race cover "2"

TIP

Apply the lithium-soap-based grease on the bearing and bearing race cover lip.

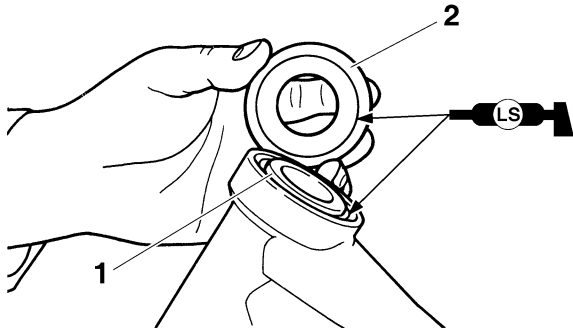

3. Install:

- Lower bracket "1"

TIP

Apply the lithium-soap-based grease on the bearing, the portion "a" and thread of the steering stem.

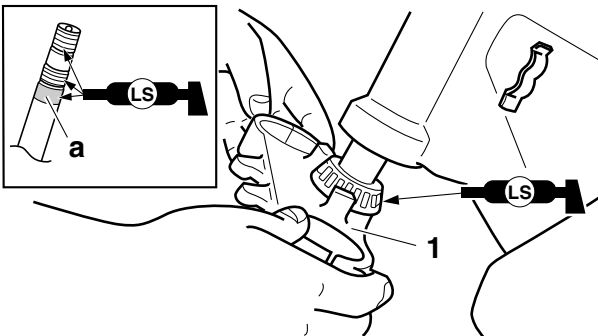

4. Install:

- Steering ring nut "1"



Steering ring nut
7 N·m (0.7 kgf·m, 5.2 lb·ft)

TIP

Install the steering ring nut with its stepped side "a" facing downward.

Tighten the steering ring nut with a steering nut wrench "2".

Refer to "CHECKING AND ADJUSTING THE STEERING HEAD" on page 3-23.

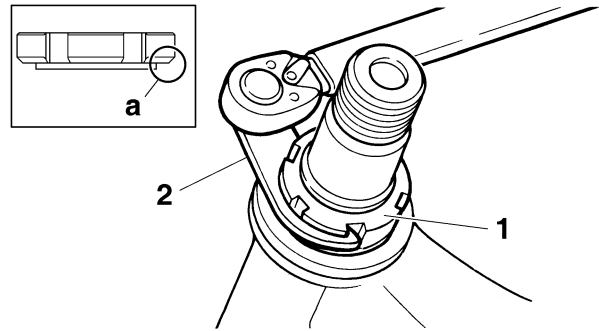

5. Check the steering stem by turning this lock to lock. If there is any binding, remove the steering stem and check the steering bearing.

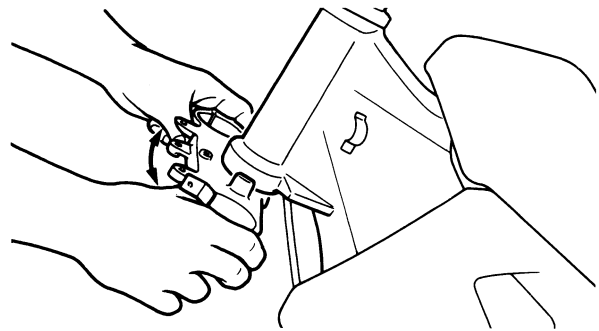

6. Install:

- Washer "1"

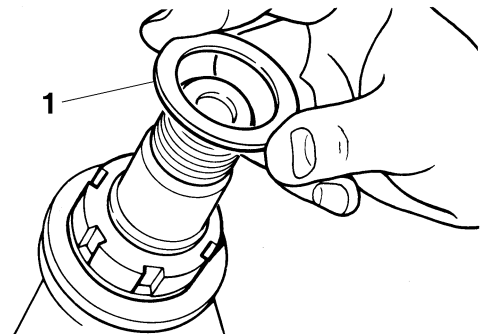

7. Install:

- Front fork "1"
- Upper bracket "2"

TIP

• Temporarily tighten the lower bracket pinch bolts.

• Do not tighten the upper bracket pinch bolts yet.

STEERING HEAD

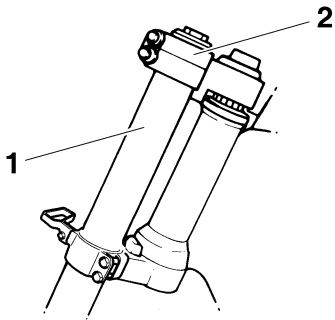

Upper bracket pinch bolt
21 N·m (2.1 kgf·m, 15 lb·ft)

- Lower bracket pinch bolt “2”



Lower bracket pinch bolt
21 N·m (2.1 kgf·m, 15 lb·ft)

EWA19330

⚠ WARNING

Tighten the lower bracket to specified torque. If torqued too much, it may cause the front fork to malfunction.

8. Install:

- Steering stem nut “1”



Steering stem nut
145 N·m (14.5 kgf·m, 107 lb·ft)

TIP

Apply the lithium-soap-based grease to the contact surface of the steering stem nut when installing.

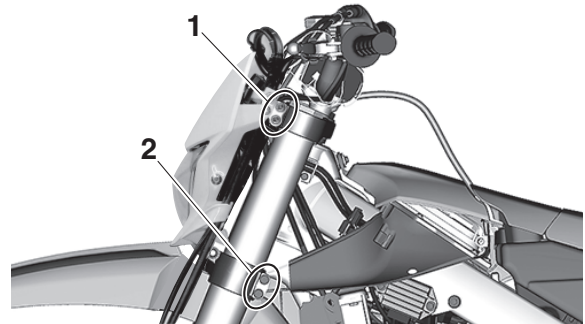
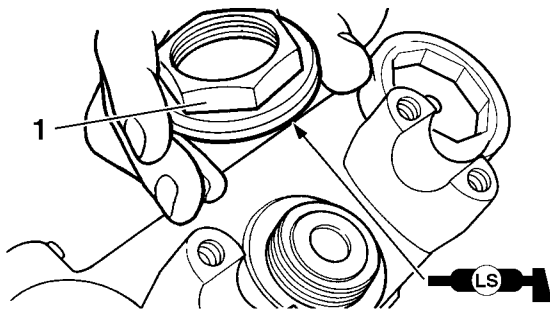

9. After tightening the nut, check the steering for smooth movement. If not, adjust the steering by loosening the steering ring nut little by little.

10. Adjust:

- Front fork top end “a”



Front fork top end (standard) “a”
5 mm (0.20 in)

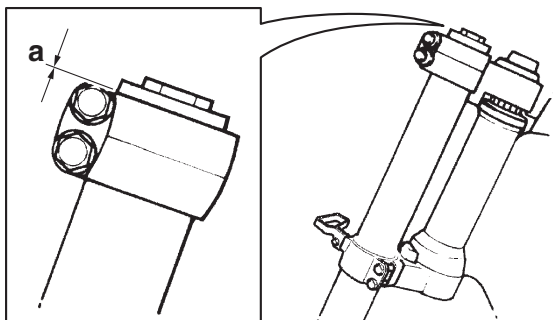

11. Tighten:

- Upper bracket pinch bolt “1”

REAR SHOCK ABSORBER ASSEMBLY

EAM20102

REAR SHOCK ABSORBER ASSEMBLY

EAM30065

REMOVING THE REAR SHOCK ABSORBER ASSEMBLY

1. Use a maintenance stand to raise the rear wheel off the ground.

EWA13120

WARNING

Securely support the vehicle so that there is no danger of it falling over.

2. Remove:

- Rear shock absorber assembly lower bolt "1"

TIP

While removing the rear shock absorber assembly lower bolt, hold the swingarm so that it does not drop down.

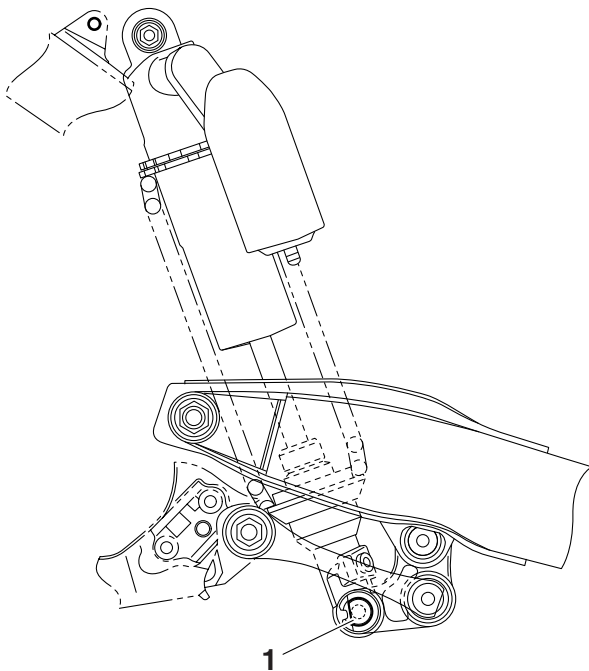

3. Remove:

- Rear shock absorber assembly upper bolt
- Rear shock absorber assembly

EAM30067

CHECKING THE REAR SHOCK ABSORBER ASSEMBLY

1. Check:

- Rear shock absorber rod
Bends/damage → Replace the rear shock absorber assembly.
- Rear shock absorber
Gas leaks/oil leaks → Replace the rear shock

absorber assembly.

- Spring
Damage/wear → Replace.
- Spring guide
Damage/wear → Replace.
- Bearing
Damage/wear → Replace.
- Bolt
Bends/damage/wear → Replace.

EAM20103

SWINGARM

EAM30071

REMOVING THE SWINGARM

1. Use a maintenance stand to raise the rear wheel off the ground.

EWA13120



Securely support the vehicle so that there is no danger of it falling over.

2. Measure:
 - Swingarm side play
 - Swingarm vertical movement
 - a. Measure the tightening torque of the pivot shaft nut.



**Pivot shaft nut
85 N·m (8.5 kgf·m, 63 lb·ft)**

- b. Check the swingarm side play “a” by moving the swingarm from side to side. If the swingarm has side-to-side play, check the bushings, the bearings, and the collars.
- c. Check the swingarm vertical movement “b” by moving the swingarm up and down. If swingarm vertical movement is not smooth or if there is binding, check the bushings, the bearings, and the collars.

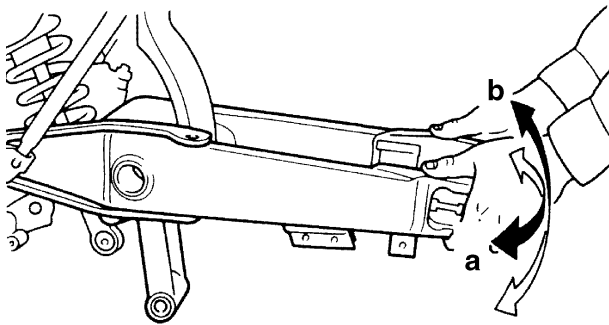

EAM20104

CHAIN DRIVE

EAM30075

REMOVING THE DRIVE CHAIN

1. Stand the vehicle on a level surface.

EWA13120

WARNING

Securely support the vehicle so that there is no danger of it falling over.

TIP

Place the vehicle on a maintenance stand so that the rear wheel is elevated.

2. Remove:

- Drive chain

TIP

Cut the drive chain with the drive chain cut & rivet tool. (Use goods on the market.)

EAM30076

CHECKING THE DRIVE CHAIN

1. Measure:

- 15-link section of the drive chain
Out of specification → Replace the drive chain.



**15-link length limit
239.3 mm (9.42 in)**

- a. Measure the length “a” between the inner sides of the pins and the length “b” between the outer sides of the pins on a 15-link section of the drive chain as shown in the illustration.

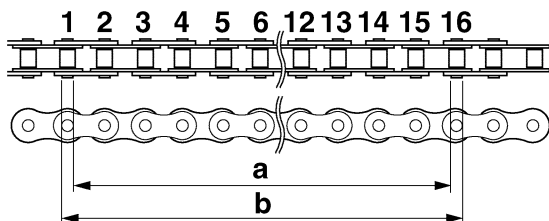

- b. Calculate the length “c” of the 15-link section of the drive chain using the following formula.

Drive chain 15-link section length “c” = (length “a” between pin inner sides + length “b” between pin outer sides)/2

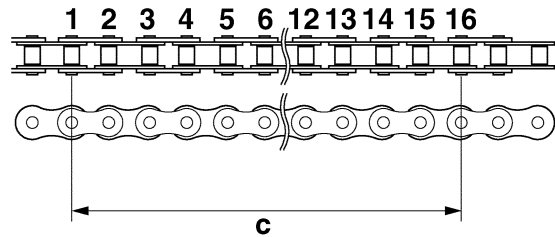

TIP

- When measuring a 15-link section of the drive chain, make sure that the drive chain is taut.
- Perform this procedure 2–3 times, at a different location each time.

2. Check:

- Drive chain
Stiffness → Clean, lubricate, or replace.

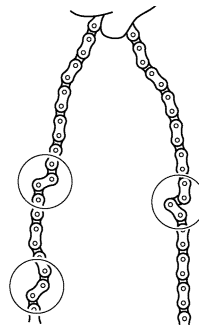

3. Clean:

- Drive chain
 - Wipe the drive chain with a clean cloth.
 - Put the drive chain in kerosene and remove any remaining dirt.
 - Remove the drive chain from the kerosene and completely dry it.

ECA19090

NOTICE

- This vehicle has a drive chain with small rubber O-rings “1” between the drive chain side plates. Never use high-pressure water or air, steam, gasoline, certain solvents (e.g., benzine), or a coarse brush to clean the drive chain. High-pressure methods could force dirt or water into the drive chain’s internals, and solvents will deteriorate the O-rings. A coarse brush can also damage the O-rings. Therefore, use only kerosene to clean the drive chain.
- Do not soak the drive chain in kerosene for more than ten minutes, otherwise the O-rings can be damaged.

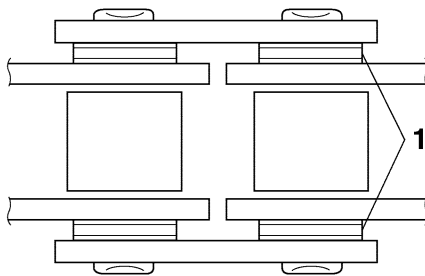
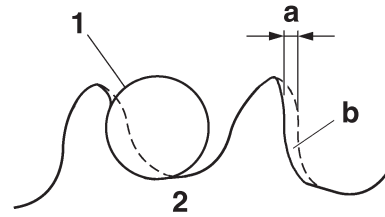
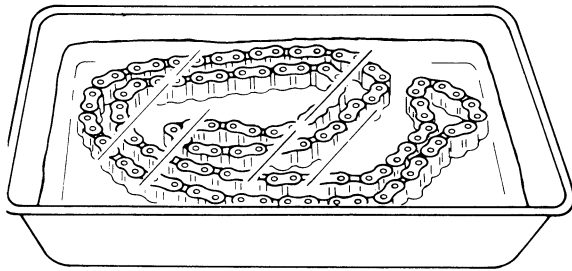

4. Check:
- O-ring "1"
Damage → Replace the drive chain.
 - Drive chain roller "2"
Damage/wear → Replace the drive chain.
 - Drive chain side plate "3"
Damage/wear → Replace the drive chain.

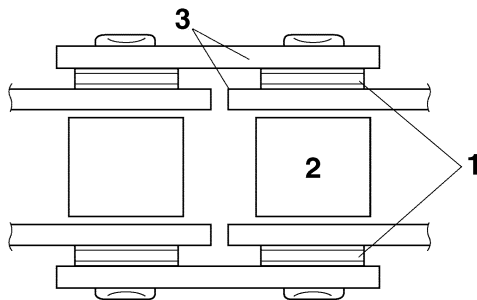

5. Lubricate:
- Drive chain



EAM30077

CHECKING THE DRIVE SPROCKET

1. Check:
- Drive sprocket
More than 1/4 tooth wear "a" → Replace the drive sprocket and the rear wheel sprocket as a set.
Bent tooth → Replace the drive sprocket and the rear wheel sprocket as a set.

b. Correct

1. Drive chain roller
2. Drive sprocket

EAM30078

CHECKING THE REAR WHEEL SPROCKET

Refer to "CHECKING AND REPLACING THE REAR WHEEL SPROCKET" on page 4-5.

EAM30079

INSTALLING THE DRIVE CHAIN

1. Install:
- Drive chain

ECA17410

NOTICE

Be sure to put on safety goggles when working.

TIP

Install the master link with the drive chain cut & rivet tool. (Use goods on the market.)

- a. When press fitting the master link plate "1", make sure the space "a" between the end of the connecting pin "2" and the master link plate is 1.2–1.4 mm (0.05–0.06 in).

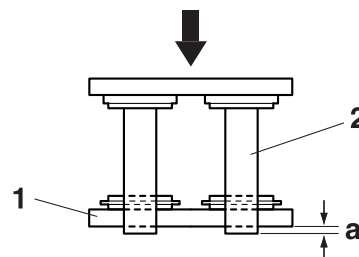

- b. After riveting, make sure the diameter between the edges "b" of the connecting pin "2" is 5.5–5.8 mm (0.22–0.23 in).

ECA24590

NOTICE

A drive chain that is too tight will overload the engine and other vital parts, and one that is too loose can skip and damage the swing-arm or cause an accident. Therefore, keep the drive chain slack within the specified limits.

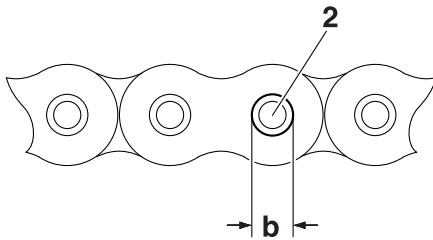

- c. After riveting, make sure the space “c”, which is inside of the master link “3” and inside of the master link plate “1”, is 12.1–12.3 mm (0.476–0.484 in).

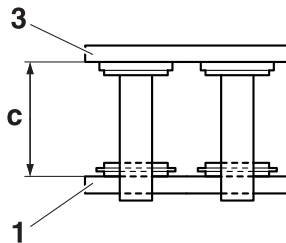

2. Lubricate:
- Drive chain



3. Install:
- Drive sprocket
 - Lock washer **New**
 - Drive sprocket nut

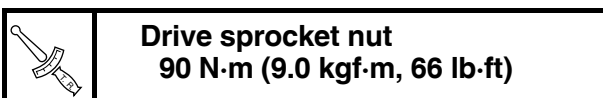

ECA14300

NOTICE

Never install a new drive chain onto worn drive chain sprockets; this will dramatically shorten the drive chain's life.

4. Adjust:
- Drive chain slack
Refer to “DRIVE CHAIN SLACK” on page 3-22.



ENGINE

| | |
|--|-----|
| EXHAUST SYSTEM | 5-1 |
| INSTALLING THE EXHAUST PIPE AND MUFFLER..... | 5-1 |
| | |
| CLUTCH | 5-2 |
| REMOVING THE CLUTCH | 5-2 |
| CHECKING THE FRICTION PLATES..... | 5-2 |
| CHECKING THE CLUTCH PLATES | 5-2 |
| CHECKING THE CLUTCH SPRINGS..... | 5-2 |
| CHECKING THE CLUTCH HOUSING | 5-2 |
| CHECKING THE CLUTCH BOSS..... | 5-3 |
| CHECKING THE PRESSURE PLATE | 5-3 |
| CHECKING THE PUSH LEVER SHAFT..... | 5-3 |
| CHECKING THE PUSH RODS | 5-3 |
| CHECKING THE PRIMARY DRIVE GEAR..... | 5-3 |
| CHECKING THE PRIMARY DRIVEN GEAR | 5-3 |
| INSTALLING THE CLUTCH..... | 5-3 |

EAM20199

EXHAUST SYSTEM

EAM30167

INSTALLING THE EXHAUST PIPE AND MUFFLER

1. Install:

- Gasket **New**
- Exhaust pipe 1 "1"
- Nut (exhaust pipe 1) "2"

| | |
|---|---|
|  | Nut (exhaust pipe 1) 10 N·m (1.0 kgf·m, 7.4 lb·ft) |
|---|---|

TIP

First temporarily tighten all nuts to 7 N·m (0.7 kgf·m, 5.2 lb·ft). Then retighten them to 10 N·m (1.0 kgf·m, 7.4 lb·ft).

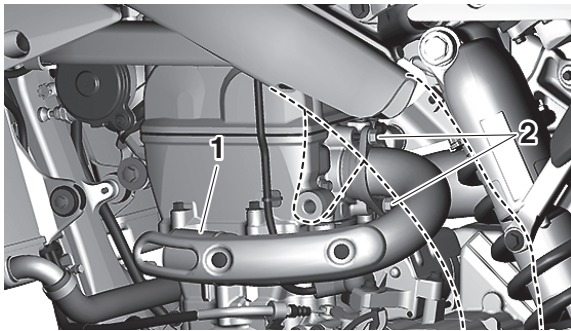

2. Install:

- Clamp
- Exhaust pipe 2 "1"
- Bolt (exhaust pipe 2) "2"

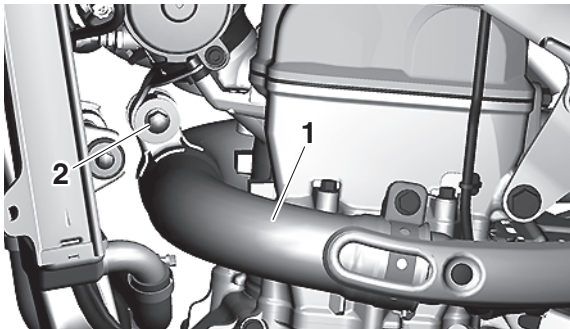

TIP

Make sure that the exhaust pipe band "3" does not ride on the projection "a" on the exhaust pipe "4" or silencer "5". Be sure to insert the projection "b" into the slot in the exhaust pipe (or silencer).

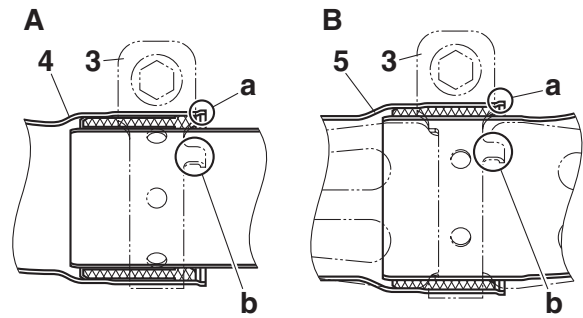

A. Exhaust pipe 1 and exhaust pipe 2

B. Exhaust pipe 2 and silencer

3. Install:

- Clamp
- Silencer "1"
- Bolt (silencer) "2"

| | |
|---|---|
|  | Bolt (silencer) 30 N·m (3.0 kgf·m, 22 lb·ft) |
|---|---|

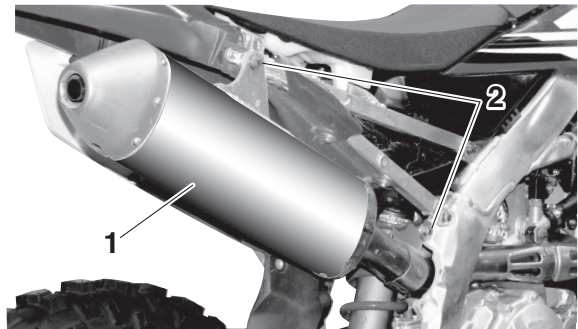

4. Tighten:

- Bolt (exhaust pipe 2)

| | |
|---|---|
|  | Bolt (exhaust pipe 2) 20 N·m (2.0 kgf·m, 15 lb·ft) |
|---|---|

- Clamp

| | |
|---|--|
|  | Clamp 12 N·m (1.2 kgf·m, 8.9 lb·ft) |
|---|--|

TIP

Tighten while checking that their front and rear joints are inserted in position.

EAM20111

CLUTCH

EAM30108

REMOVING THE CLUTCH

1. Remove:

- Clutch boss nut "1"
- Lock washer "2"
- Clutch boss "3"

TIP

- Straighten the lock washer tab.
- While holding the clutch boss with the clutch holder "4", loosen the clutch boss nut.



Clutch holder
90890-04199
Universal clutch holder
YM-91042

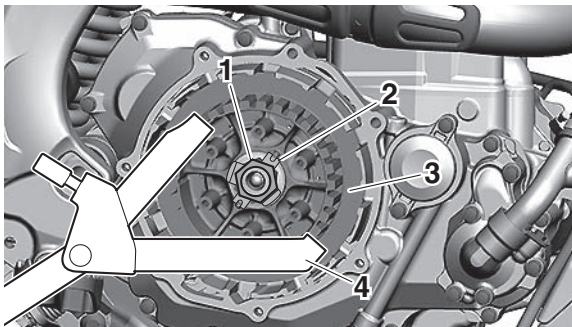

EAM30109

CHECKING THE FRICTION PLATES

1. Check:

- Friction plate
 Damage/wear → Replace the friction plates as a set.

2. Measure:

- Friction plate thickness
 Out of specification → Replace the friction plates as a set.

TIP

Measure it at four points on the friction plate.



Friction plate 1 thickness
2.92–3.08 mm (0.115–0.121 in)
Wear limit
2.82 mm (0.111 in)
Friction plate 2 thickness
2.92–3.08 mm (0.115–0.121 in)
Wear limit
2.82 mm (0.111 in)

EAM30110

CHECKING THE CLUTCH PLATES

1. Check:

- Clutch plate

Damage → Replace the clutch plates as a set.

2. Measure:

- Clutch plate warpage
 (with a surface plate and thickness gauge)
 Out of specification → Replace the clutch plates as a set.



Thickness gauge
90890-03268
Feeler gauge set
YU-26900-9



Warpage limit
0.10 mm (0.004 in)

EAM30111

CHECKING THE CLUTCH SPRINGS

1. Check:

- Clutch spring
 Damage → Replace the clutch springs as a set.

2. Measure:

- Clutch spring free length
 Out of specification → Replace the clutch springs as a set.



Clutch spring free length
48.00 mm (1.89 in)
Clutch spring free length limit
45.60 mm (1.80 in)

EAM30112

CHECKING THE CLUTCH HOUSING

1. Check:

- Clutch housing dogs "1"
 Damage/pitting/wear → Deburr the clutch housing dogs or replace the clutch housing.

TIP

Pitting on the clutch housing dogs will cause erratic clutch operation.

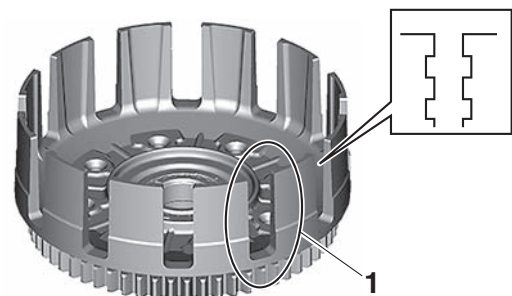

EAM30113

CHECKING THE CLUTCH BOSS

1. Check:

- Clutch boss splines
Damage/pitting/wear → Replace the clutch boss.

TIP

Pitting on the clutch boss splines will cause erratic clutch operation.

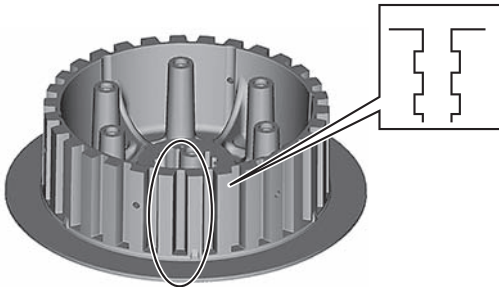

EAM30114

CHECKING THE PRESSURE PLATE

1. Check:

- Pressure plate
Crack/damage → Replace.

EAM30115

CHECKING THE PUSH LEVER SHAFT

1. Check:

- Push lever shaft
Wear/damage → Replace.

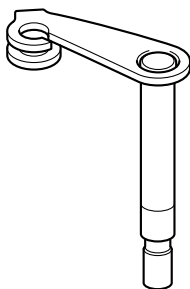

EAM30484

CHECKING THE PUSH RODS

1. Check:

- Push rod 1 “1”
 - Bearing/Washer “2”
 - Push rod 2 “3”
 - Ball “4”
- Cracks/damage/wear → Replace.

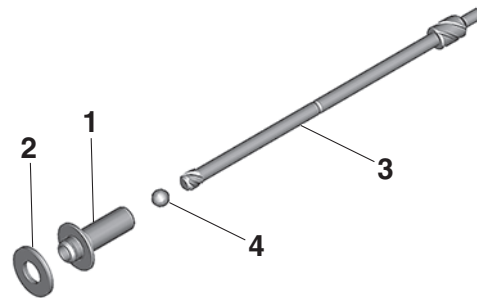

2. Measure:

- Push rod 2 bending limit
Out of specification → Replace.



**Push rod bending limit
0.10 mm (0.004 in)**

EAM30117

CHECKING THE PRIMARY DRIVE GEAR

1. Check:

- Primary drive gear
Damage/wear → Replace the primary drive and primary driven gears as a set.
Excessive noise during operation → Replace the primary drive and primary driven gears as a set.

2. Check:

- Primary-drive-gear-to-primary-driven-gear free play
Free play exists → Replace the primary drive and primary driven gears as a set.

EAM30118

CHECKING THE PRIMARY DRIVEN GEAR

1. Check:

- Primary driven gear
Damage/wear → Replace the primary drive and primary driven gears as a set.
Excessive noise during operation → Replace the primary drive and primary driven gears as a set.

EAM30121

INSTALLING THE CLUTCH

1. Install:

- Oil seal “1” **New**
- Washer “2”
- Circlip “3” **New**

TIP

- Apply the lithium-soap-based grease on the oil seal lip.
- Install the oil seal in parallel with its manufacture’s marks or numbers facing inward.

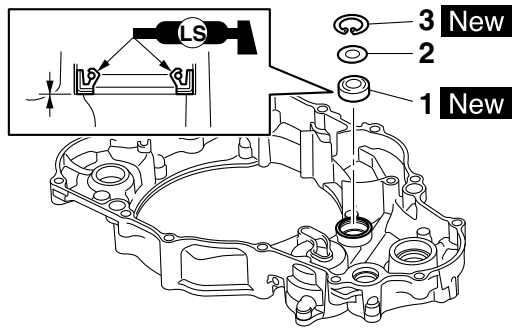

2. Install:

- Dowel pin "1"
- O-ring "2" **New**
- Collar "3"
- Gasket "4" **New**

TIP

Apply the lithium-soap-based grease on the O-ring.

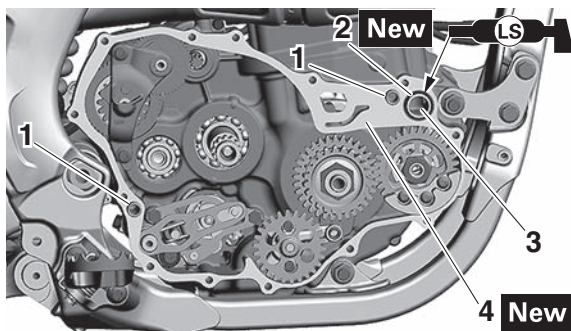

3. Install:

- Crankcase cover (right) "1"
- Crankcase cover bolt (right) "2"



Crankcase cover bolt (right)
10 N·m (1.0 kgf·m, 7.4 lb·ft)

TIP

- Apply the engine oil on the impeller shaft end.
- When installing the crankcase cover onto the crankcase, make sure that the impeller shaft end "3" aligns with the balancer end slot "4".
- Tighten the crankcase cover bolts (right) in stages and in a crisscross pattern.

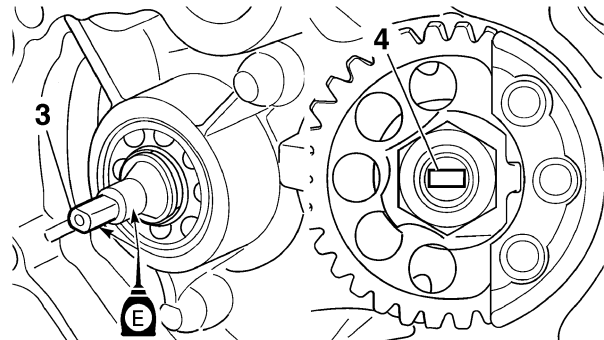
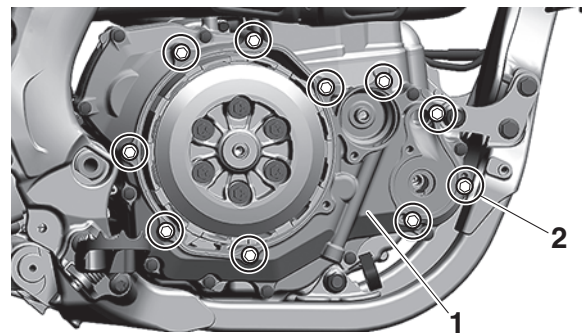

4. Install:

- Push lever shaft "1"

TIP

- Apply the lithium-soap-based grease on the oil seal lip.
- Before installation, apply the engine oil to the bearings (upper side and lower side).

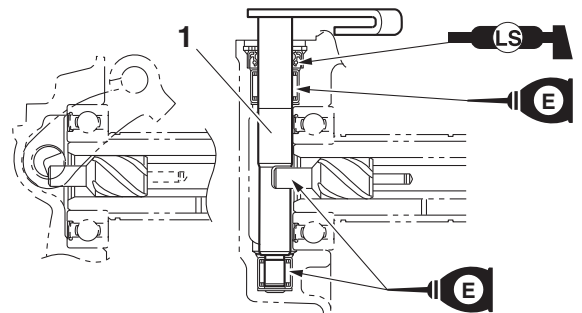

5. Install:

- Primary driven gear "1"
- Thrust washer "2"
- Clutch boss "3"

TIP

Apply the engine oil on the primary driven gear inner circumference.

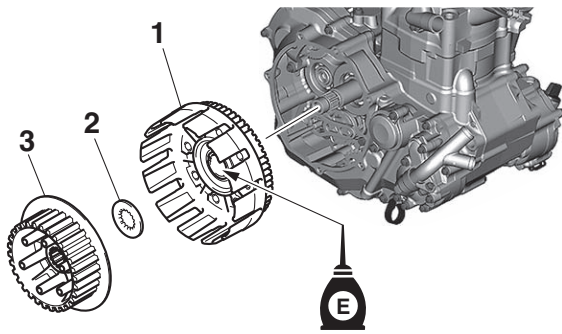

6. Install:

- Lock washer “1” **New**
- Clutch boss nut “2”

| | |
|--|---|
| | Clutch boss nut 75 N·m (7.5 kgf·m, 55 lb-ft) |
|--|---|

ECA24660

NOTICE

Make sure to tighten to specification; otherwise, it may damage the other part that is fastened together.

TIP

- Align the notch in the lock washer “1” with the detent rib “a” of the clutch boss.
- Apply engine oil to the threads and contact surface of the clutch boss nut.
- Use the clutch holder “3” to hold the clutch boss.

| | |
|--|---|
| | Clutch holder 90890-04199 Universal clutch holder YM-91042 |
|--|---|

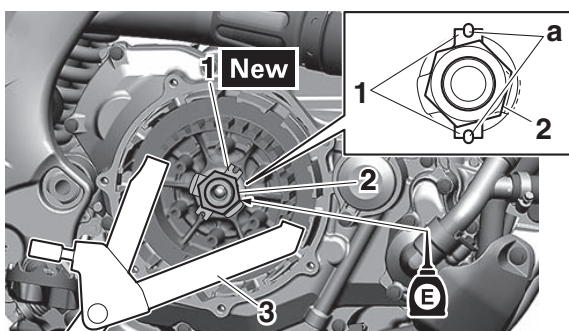

7. Bend the lock washer “1” tab.

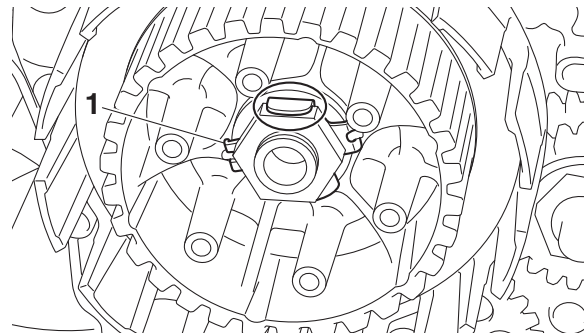

8. Install:

- Friction plate 1 “1”
- Clutch plate “2”
- Friction plate 2 “3”

TIP

- Install the clutch plates and friction plates alternately on the clutch boss, starting with a friction plate and ending with a friction plate.
- From the clutch boss side, install the friction plates in order: friction plate 1 (identification color: black) × 1, friction plate 2 (identification color: purple) × 6, and friction plate 1 (identification color: black) × 1.
- Apply the engine oil on the friction plates and clutch plates.

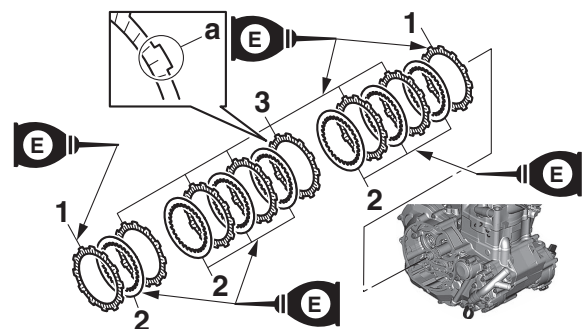

a. Identification color

9. Install:

- Bearing “1”
- Washer “2”
- Circlip “3” **New**
(to the push rod 1 “4”)

TIP

Apply the engine oil on the bearing, washer and push rod 1.

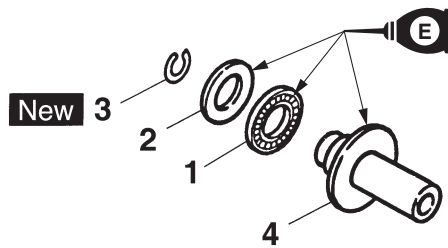

10. Install:
- Push rod 2 "1"
 - Ball "2"
 - Push rod 1 "3"

TIP
Apply the engine oil on the push rod 1, 2 and ball.

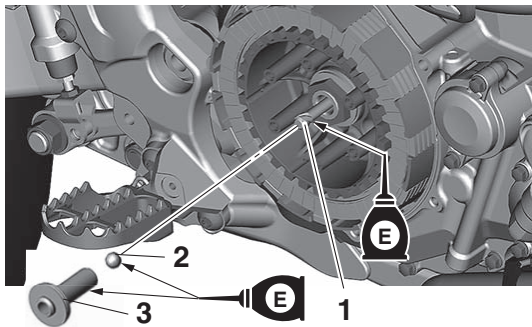

11. Install:
- Pressure plate "1"

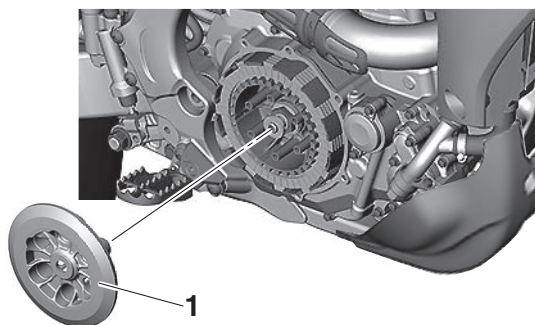

12. Install:
- Clutch spring
 - Clutch spring bolt

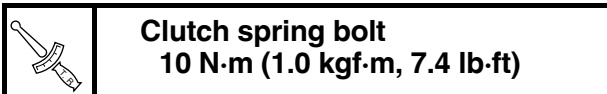

TIP
Tighten the bolts in stages and in a crisscross pattern.

13. Install:
- O-ring "1" **New**

TIP
Apply the lithium-soap-based grease to the O-ring.

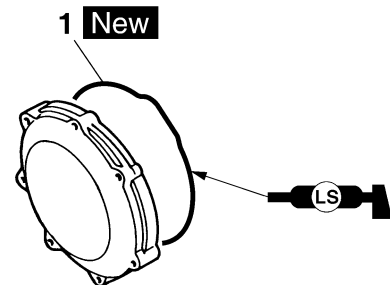

14. Install:
- Clutch cover
 - Clutch cover bolt

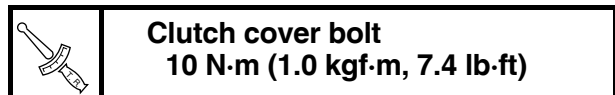

TIP
Tighten the bolts in stages and in a crisscross pattern.

FUEL SYSTEM

| | |
|-------------------------------|-----|
| FUEL TANK | 6-1 |
| REMOVING THE FUEL TANK..... | 6-1 |
| INSTALLING THE FUEL TANK..... | 6-1 |

EAM20140

FUEL TANK

EAM30263

REMOVING THE FUEL TANK

1. Extract the fuel in the fuel tank through the fuel tank cap with a pump.
2. Remove:
 - Fuel hose coupler

EWA19370

WARNING

Cover the fuel hose connection with a cloth when disconnecting it. This is because residual pressure in the fuel hose could cause fuel to spurt out when the hose is removed.

ECA26520

NOTICE

- Make sure that the fuel hose is disconnected by hand. Do not forcefully disconnect the hose with tools.
- When removing the fuel tank, handle it carefully. If the discharge port of the fuel pump touches the ground or other objects, the discharge port could be damaged.

TIP

- To disconnect the fuel hose from the fuel tank, remove the fuel hose connector holder "a", and then slide the fuel hose connector cover.
- To remove the fuel hose from the fuel rail, slide the fuel hose connector cover "1" on the end of the hose in the direction of the arrow shown, press the two buttons "2" on the sides of the connector, and then remove the hose.
- Before removing the hose, place a few cloths in the area under where it will be removed.
- To prevent sand, dust, and other foreign materials from entering the fuel pump, install the included fuel hose joint cover 1 "3" and the fuel hose joint cover 2 "4" onto the disconnected fuel hose and the fuel pump.

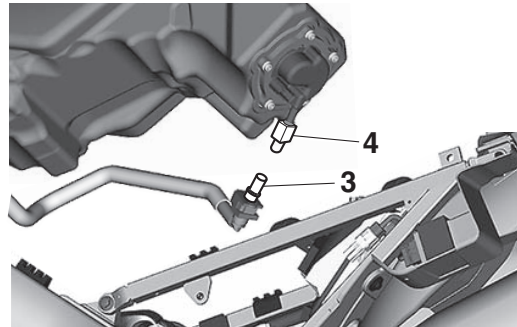
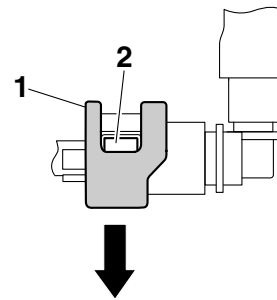
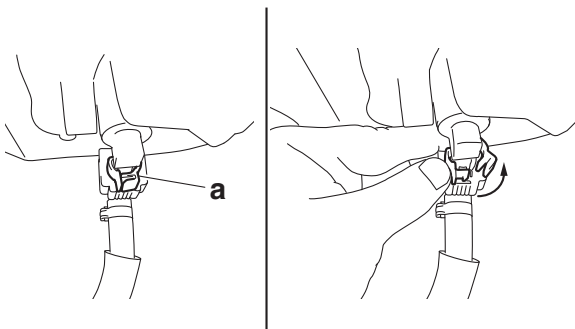

3. Remove:
 - Side cover (left/right)
 - Seat
 - Air scoop (left/right)
 - Fuel tank

TIP

Do not set the fuel tank down on the installation surface of the fuel pump. Be sure to lean the fuel tank against a wall or the like.

EAM30267

INSTALLING THE FUEL TANK

1. Install:
 - Fuel tank
2. Connect:
 - Fuel hose

ECA24740

NOTICE

- Connect the fuel hose securely, and check that the orientation of the installed fuel hose holder is correct.
- Take care not to kink or pinch the fuel hose.

TIP

- Insert the fuel hose into the fuel pipe securely until you hear a "click".
- Slide the fuel hose connector cover "1" at the hose end in the direction of the arrow.
- Install the fuel hose connector holder "a".
- Check that the fuel hose and the fuel pump lead are routed through the guide on the cover.

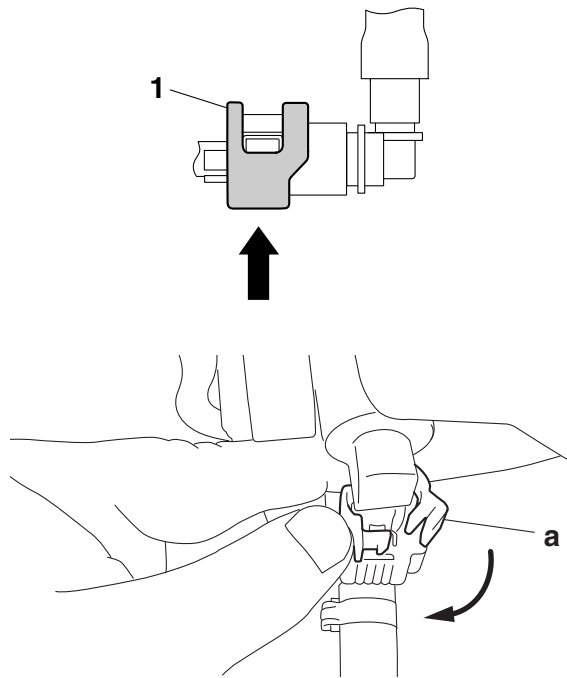

3. Connect:

- Fuel pump coupler

4. Install:

- Air scoop (left/right)
- Seat
- Side cover (left/right)

Refer to "GENERAL CHASSIS" on page 4-1.

ELECTRICAL SYSTEM

| | |
|---|-----|
| FUEL INJECTION SYSTEM | 7-1 |
| ECU SELF-DIAGNOSTIC FUNCTION..... | 7-1 |
| | |
| ELECTRICAL COMPONENTS | 7-3 |
| CHECKING THE BULBS AND BULB SOCKETS | 7-3 |
| CHECKING THE FUSES | 7-3 |
| CHECKING AND CHARGING THE BATTERY | 7-4 |

EAM20145

FUEL INJECTION SYSTEM

EAM30352

ECU SELF-DIAGNOSTIC FUNCTION

The ECU is equipped with a self-diagnostic function in order to ensure that the fuel injection system is operating normally. If this function detects a malfunction in the system, it immediately operates the engine under substitute characteristics and illuminates the engine trouble warning light to alert the rider that a malfunction has occurred in the system. Once a malfunction has been detected, a fault code number is stored in the memory of the ECU.

- To inform the rider that the fuel injection system is not functioning, the engine trouble warning light flashes while the start switch is being pushed to start the engine.
- If a malfunction is detected in the system by the self-diagnostic function, the ECU provides an appropriate substitute characteristic operation, and alerts the rider of the detected malfunction by illuminating the engine trouble warning light.

Engine trouble warning light indication and fuel injection system operation

| Warning light indication | ECU operation | Fuel injection operation | Vehicle operation |
|--------------------------|--|--|---|
| Flashing* | Warning provided when unable to start engine | Operation stopped | Cannot be operated |
| Remains on | Malfunction detected | Operated with substitute characteristics in accordance with the description of the malfunction | Can or cannot be operated depending on the fault code |

* The engine trouble warning light flashes when any one of the following conditions is present and the start switch is pushed:

- | | |
|---|--|
| 12: Crankshaft position sensor | 41: Lean angle sensor (open or short circuit) |
| 30: Lean angle sensor (latch up detected) | 50: ECU internal malfunction (faulty ECU memory) |
| 33: Ignition coil (Malfunction detected in the primary wire of the ignition coil) | |

Checking the engine trouble warning light

The engine trouble warning light comes on for around 2 seconds when pushing the start switch.

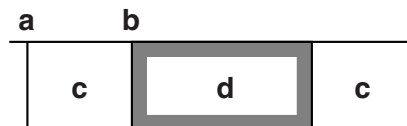

- Start switch is not being pushed.
- Start switch is being pushed.
- Engine trouble warning light goes off
- Engine trouble warning light comes on for around 2 seconds

FUEL INJECTION SYSTEM

ECU detects an abnormal signal from a sensor

If the ECU detects an abnormal signal from a sensor while the vehicle is being driven, the ECU illuminates the engine trouble warning light and provides the engine with alternate operating instructions that are appropriate for the type of malfunction.

When an abnormal signal is received from a sensor, the ECU processes the specified values that are programmed for each sensor in order to provide the engine with alternate operating instructions that enable the engine to continue operating or stop operating, depending on the conditions.

EAM20147

ELECTRICAL COMPONENTS

EAM30357

CHECKING THE BULBS AND BULB SOCKETS

- Remove:
 - Bulb

ECA25930

NOTICE

Be sure to hold the socket firmly when removing the bulb. Never pull the lead, otherwise it may be pulled out of the terminal in the coupler.

- Check:
 - Bulb (for continuity) (with the digital circuit tester)
No continuity → Replace.



Digital circuit tester (CD732)
90890-03243
Model 88 Multimeter with tachometer
YU-A1927

TIP

Before checking for continuity, set the digital circuit tester to “Ω” range.

- Check:
 - Bulb socket (for continuity) (with the digital circuit tester)
No continuity → Replace.



Digital circuit tester (CD732)
90890-03243
Model 88 Multimeter with tachometer
YU-A1927

TIP

Check each bulb socket for continuity in the same manner as described in the bulb section; however, note the following.

- Install a good bulb into the bulb socket.
- Connect the digital circuit tester probes to the respective leads of the bulb socket.
- Check the bulb socket for continuity. If any of the readings indicate no continuity, replace the bulb socket.

EAM30290

CHECKING THE FUSES

The following procedure applies to all of the fuses.

- Remove:
 - Seat
Refer to “GENERAL CHASSIS” on page 4-1.
- Check:
 - Main fuse “1”
 - Radiator fan motor fuse “2”

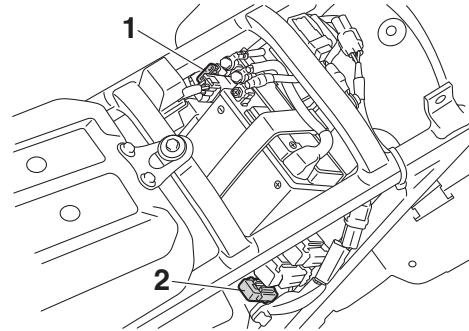

- Connect the digital circuit tester to the fuse and check the continuity.

TIP

Set the digital circuit tester selector to “Ω”.



Digital circuit tester (CD732)
90890-03243
Model 88 Multimeter with tachometer
YU-A1927

- If the digital circuit tester indicates “O.L”, replace the fuse.

- Replace:
 - Fuse
 - Install a new fuse of the correct amperage rating.
 - Push the start switch to verify if the electrical circuit is operational.
 - If the fuse immediately blows again, have a Yamaha dealer check the electrical system.

| Fuses | Amperage rating | Q'ty |
|--------------------|-----------------|------|
| Main | 15 A | 1 |
| Spare | 15 A | 1 |
| Radiator fan motor | 5 A | 1 |

EWA13310

WARNING

Never use a fuse with an amperage rating other than that specified. Improvising or using a fuse with the wrong amperage rating may cause extensive damage to the electrical system, cause the lighting and ignition systems to malfunction and could possibly

cause a fire.

4. Install:

- Seat

EAM30291

CHECKING AND CHARGING THE BATTERY

EWA13290

WARNING

Batteries generate explosive hydrogen gas and contain electrolyte which is made of poisonous and highly caustic sulfuric acid. Therefore, always follow these preventive measures:

- Wear protective eye gear when handling or working near batteries.
- Charge batteries in a well-ventilated area.
- Keep batteries away from fire, sparks or open flames (e.g., welding equipment, lighted cigarettes).
- DO NOT SMOKE when charging or handling batteries.
- KEEP BATTERIES AND ELECTROLYTE OUT OF REACH OF CHILDREN.
- Avoid bodily contact with electrolyte as it can cause severe burns or permanent eye injury.

FIRST AID IN CASE OF BODILY CONTACT: EXTERNAL

- Skin — Wash with water.
- Eyes — Flush with water for 15 minutes and get immediate medical attention.

INTERNAL

- Drink large quantities of water or milk followed with milk of magnesia, beaten egg or vegetable oil. Get immediate medical attention.

ECA13661

NOTICE

- This is a VRLA (Valve Regulated Lead Acid) battery. Never remove the sealing caps because the balance between cells will not be maintained and battery performance will deteriorate.
- Charging time, charging amperage and charging voltage for a VRLA (Valve Regulated Lead Acid) battery are different from those of conventional batteries. The VRLA (Valve Regulated Lead Acid) battery should be charged according to the appropriate charging method. If the battery is overcharged, the electrolyte level will drop considerably. Therefore, take special care when charging the battery.

TIP

Since VRLA (Valve Regulated Lead Acid) batteries are sealed, it is not possible to check the charge state of the battery by measuring the specific gravity of the electrolyte. Therefore, the charge of the battery has to be checked by measuring the voltage at the battery terminals.

1. Remove:

- Side cover (left/right)
- Seat

Refer to “GENERAL CHASSIS” on page 4-1.

2. Disconnect:

- Battery lead
(from the battery terminals)

ECA13700

NOTICE

First, disconnect the negative battery lead, and then the positive battery lead.

3. Remove:

- Battery

4. Check:

- Battery charge
 - a. Connect a digital circuit tester to the battery terminals.

- Positive tester probe → positive battery terminal
- Negative tester probe → negative battery terminal

TIP

- The charge state of a VRLA (Valve Regulated Lead Acid) battery can be checked by measuring its open-circuit voltage (i.e., the voltage when the positive battery terminal is disconnected).
- No charging is necessary when the open-circuit voltage equals or exceeds 12.8 V.

- b. Check the charge of the battery, as shown in the charts and the following example.

Example
Open-circuit voltage = 12.0 V
Charging time = 6.5 hours
Charge of the battery = 20–30 %

ELECTRICAL COMPONENTS

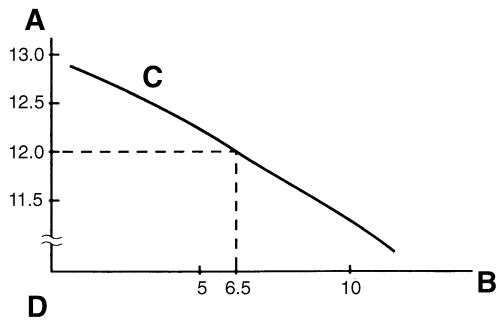

- A. Open-circuit voltage (V)
 B. Charging time (hours)
 C. Relationship between the open-circuit voltage and the charging time at 20 °C (68 °F)
 D. These values vary with the temperature, the condition of the battery plates, and the electrolyte level.

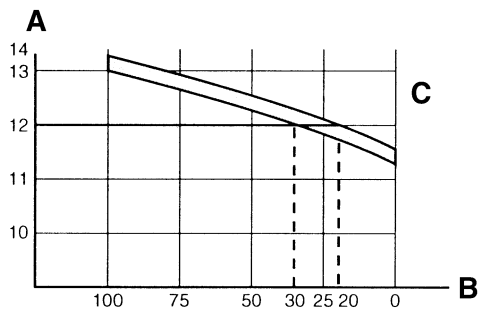

- A. Open-circuit voltage (V)
 B. Charging condition of the battery (%)
 C. Ambient temperature 20 °C (68 °F)

5. Charge:

- Battery

(refer to the appropriate charging method)

EWA19390



WARNING

Do not quick charge a battery.

ECA24800

NOTICE

- Do not use a high-rate battery charger since it forces a high-amperage current into the battery quickly and can cause battery overheating and battery plate damage.
- If it is impossible to regulate the charging current on the battery charger, be careful not to overcharge the battery.
- When charging a battery, be sure to remove it from the vehicle. (If charging has to be done with the battery mounted on the vehicle, disconnect the negative battery lead from the battery terminal.)
- To reduce the chance of sparks, do not plug in the battery charger until the battery

charger leads are connected to the battery.

- Before removing the battery charger lead clips from the battery terminals, be sure to turn off the battery charger.
- Make sure the battery charger lead clips are in full contact with the battery terminal and that they are not shorted. A corroded battery charger lead clip may generate heat in the contact area and a weak clip spring may cause sparks.
- If the battery becomes hot to the touch at any time during the charging process, disconnect the battery charger and let the battery cool before reconnecting it. Hot batteries can explode!
- As shown in the following illustration, the open-circuit voltage of a VRLA (Valve Regulated Lead Acid) battery stabilizes about 30 minutes after charging has been completed. Therefore, wait 30 minutes after charging is completed before measuring the open-circuit voltage.

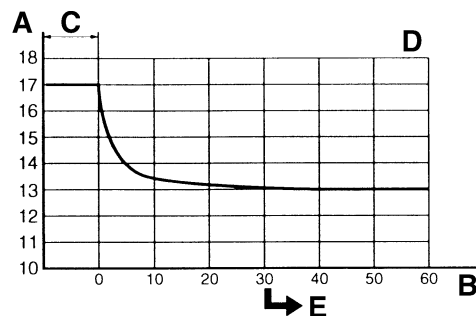

- A. Open-circuit voltage (V)
 B. Time (minutes)
 C. Charging
 D. Ambient temperature 20 °C (68 °F)
 E. Check the open-circuit voltage.

Charging method using a variable-current (voltage) charger

- a. Measure the open-circuit voltage prior to charging.

TIP

Voltage should be measured 30 minutes after the engine is stopped.

- b. Connect a charger and ammeter to the battery and start charging.

TIP

Set the charging voltage to 16–17 V. If the setting is lower, charging will be insufficient. If too high, the battery will be over-charged.

- c. Make sure that the current is higher than

ELECTRICAL COMPONENTS

the standard charging current written on the battery.

TIP

If the current is lower than the standard charging current written on the battery, set the charging voltage adjust dial at 20–24 V and monitor the amperage for 3–5 minutes to check the battery.

- Standard charging current is reached
Battery is good.
- Standard charging current is not reached
Replace the battery.

- d. Adjust the voltage so that the current is at the standard charging level.
- e. Set the time according to the charging time suitable for the open-circuit voltage.
- f. If charging requires more than 5 hours, it is advisable to check the charging current after a lapse of 5 hours. If there is any change in the amperage, readjust the voltage to obtain the standard charging current.
- g. Measure the battery open-circuit voltage after leaving the battery unused for more than 30 minutes.

12.8 V or more --- Charging is complete.
12.7 V or less --- Recharging is required.
Under 12.0 V --- Replace the battery.

Charging method using a constant voltage charger

- a. Measure the open-circuit voltage prior to charging.

TIP

Voltage should be measured 30 minutes after the engine is stopped.

- b. Connect a charger and ammeter to the battery and start charging.
- c. Make sure that the current is higher than the standard charging current written on the battery.

TIP

If the current is lower than the standard charging current written on the battery, this type of battery charger cannot charge the VRLA (Valve Regulated Lead Acid) battery. A variable voltage charger is recommended.

- d. Charge the battery until the battery's charging voltage is 15 V.

TIP

Set the charging time at 20 hours (maximum).

- e. Measure the battery open-circuit voltage

after leaving the battery unused for more than 30 minutes.

12.8 V or more --- Charging is complete.
12.7 V or less --- Recharging is required.
Under 12.0 V --- Replace the battery.

6. Install:
 - Battery
7. Connect:
 - Battery lead
(to the battery terminals)

ECA26980

NOTICE

First, connect the positive battery lead, and then the negative battery lead.

8. Check:
 - Battery terminal
Dirt → Clean with a wire brush.
Loose connection → Connect properly.
9. Lubricate:
 - Battery terminal



**Recommended lubricant
Dielectric grease**

10. Install:
 - Seat
 - Side cover (left/right)

TROUBLESHOOTING

| | |
|--|------|
| TROUBLESHOOTING | 8-1 |
| GENERAL INFORMATION | 8-1 |
| TROUBLESHOOTING OF ENGINE (fault code not detected)..... | 8-1 |
| TROUBLESHOOTING OF CLUTCH..... | 8-4 |
| TROUBLESHOOTING OF TRANSMISSION | 8-6 |
| TROUBLESHOOTING OF COOLING SYSTEM | 8-7 |
| TROUBLESHOOTING OF BRAKE | 8-8 |
| TROUBLESHOOTING OF SUSPENSION..... | 8-8 |
| TROUBLESHOOTING OF STEERING/HANDLING | 8-10 |
| TROUBLESHOOTING OF CHARGING SYSTEM | 8-11 |
| TROUBLESHOOTING OF LIGHTING SYSTEM..... | 8-11 |
| TROUBLESHOOTING OF SIGNALING SYSTEM | 8-11 |
| | |
| SELF-DIAGNOSTIC FUNCTION AND DIAGNOSTIC CODE TABLE | 8-12 |
| SELF-DIAGNOSTIC FUNCTION TABLE (FOR FUEL INJECTION SYSTEM)..... | 8-12 |

EAM20148

TROUBLESHOOTING

EAM30309

GENERAL INFORMATION

TIP

- Troubleshooting information provided here does not cover all the trouble symptoms, possible causes, and remedial actions. Some items may not apply depending on the model. Use this information as a guide and quick reference matrix when performing basic troubleshooting. Refer to the each chapter for detailed information on checking, adjustment, and replacement.
- The following guide for troubleshooting represent quick and easy procedures for checking these vital systems yourself. However, should your motorcycle require any repair, take it to a Yamaha dealer, whose skilled technicians have the necessary tools, experience, and know-how to service the motorcycle properly.

EAM30509

TROUBLESHOOTING OF ENGINE (fault code not detected)

TIP

If a fault code is detected, have a Yamaha dealer check the electrical system.

Engine does not crank.

| Symptom | Possible cause | Actions |
|--|---|--|
| Starter motor does not operate | Have a Yamaha dealer check the electrical system. | |
| Starter motor operates, but the engine does not crank. | Starter clutch malfunction | Replace the starter clutch. |
| | Improper oil grade (starter clutch slipping) | Change to recommended engine oil. |
| | Stuck piston or seized crankshaft | Disassemble and check the engine. Replace defective parts. |

Engine will not start or is difficult to start, but it cranks.

| Symptom | Possible cause | Actions |
|-------------------------------------|---|---|
| Spark plug does not produce a spark | Have a Yamaha dealer check the electrical system. | |
| Fuel not supplied | — | Measure the fuel pressure. |
| | Empty fuel tank | Fill the fuel tank with fuel. |
| | Clogged fuel tank cap breather hole | Clean the fuel tank cap. |
| | Clogged or damaged fuel hose | Clean, repair, or replace the fuel hose. |
| | Fuel leakage | Check the fuel passage. Repair or replace as necessary. |
| | Clogged fuel pump | Clean or replace the fuel pump. |
| | Cracks or damage in fuel pump | Replace the fuel pump. |
| | Fuel pump malfunction | Have a Yamaha dealer check the electrical system. |
| | Failed or clogged fuel injector | Replace the fuel injector. |
| | ECU failure | Replace the ECU. |

TROUBLESHOOTING

| Symptom | Possible cause | Actions |
|---------|--|--|
| — | Water or foreign material in fuel, degraded fuel | Change fuel. |
| | Loose spark plug | Tighten the spark plug to the specified torque. |
| | Loose cylinder head or cylinder | Tighten bolts or nuts on cylinder head and cylinder to the specified torque. |
| | Damaged cylinder head gasket | Replace the cylinder head gasket. |
| | Incorrect valve timing | Adjust the valve timing. |
| | Incorrect valve clearance | Adjust the valve clearance. |
| | Worn valve guide | Replace the valve guide. |
| | Bent, damaged, or stuck valve | Replace the valve. |
| | Poor contact between valve and valve seat | Reface the valve-to-valve-seat contact. |
| | Fatigued or broken valve spring | Replace the valve spring. |
| | Worn, damaged, or stuck piston ring | Replace the piston and piston rings as a set. |
| | Seized or damaged piston | Replace the piston and piston rings as a set. |
| | Worn or damaged cylinder bore | Replace the cylinder, piston, and piston rings as a set. |

Incorrect idling speed or mid-to-high speed

| Symptom | Possible cause | Actions |
|-------------------------------------|---------------------------------|---|
| Spark plug does not produce a spark | Incorrect spark plug gap | Adjust the spark plug gap. |
| | Worn or damaged spark plug | Replace the spark plug. |
| | Defective spark plug cap | Replace the spark plug cap. |
| | Defective ignition coil | Replace the ignition coil. |
| | ECU failure | Replace the ECU. |
| Low fuel pressure | — | Measure the fuel pressure. |
| | Fuel leakage | Check the fuel passage. Repair or replace as necessary. |
| | Clogged fuel pump | Clean or replace the fuel pump. |
| | Cracks or damage in fuel pump | Replace the fuel pump. |
| | Fuel pump malfunction | Have a Yamaha dealer check the electrical system. |
| Fuel not supplied | Failed or clogged fuel injector | Replace the fuel injector. |
| | ECU failure | Replace the ECU. |

TROUBLESHOOTING

| Symptom | Possible cause | Actions |
|---------|--|--|
| | Worn camshaft lobe | Replace the camshaft. |
| | Water or foreign material in fuel, degraded fuel | Change fuel. |
| | Contaminated throttle body or clogged internal passage | Clean the throttle body. |
| | Incorrectly adjusted throttle cable | Adjust the throttle grip free play. |
| | Incorrectly adjusted idling speed (idle screw) | Adjust the idle screw. |
| | Incorrect throttle position sensor angle | Adjust the throttle position sensor angle. |
| | Incorrect acceleration position sensor angle | Adjust the acceleration position sensor angle. |
| | Faulty ECU | Replace the ECU. |
| | Clogged vacuum hose | Clean the vacuum hose. |
| | Cracks and damage in vacuum hose | Replace the vacuum hose. |
| | Damaged throttle body joint | Replace the throttle body joint. |
| | Loose throttle body joint | Tighten the throttle body joint bolts to the specified torque. |
| | Clogged air filter element | Clean or replace the air filter element. |
| | Incorrect oil level (high) | Adjust the oil level to the specified level. |

Excessive noise from engine

| Symptom | Possible cause | Actions |
|---------------------------------------|--|--|
| Noise heard from around cylinder head | Incorrect valve clearance (too wide) | Adjust the valve clearance. |
| | Fatigued or broken valve spring | Replace the valve spring. |
| | Worn or damaged camshaft lobe | Replace the camshaft. |
| | Worn or damaged valve lifter | Replace the valve lifter and cylinder head as a set. |
| | Worn or damaged camshaft journal | Replace the camshaft. |
| | Worn or damaged cylinder head (camshaft journal) | Replace the cylinder head. |
| Noise heard from around timing chain | Worn or damaged timing chain | Replace the timing chain and camshaft sprocket as a set. |
| | Worn or damaged camshaft sprocket | Replace the timing chain and camshaft sprocket as a set. |
| | Worn or damaged timing chain guide | Replace the timing chain guide. |
| | Cracked, damaged, or faulty timing chain tensioner | Replace the timing chain tensioner. |

TROUBLESHOOTING

| Symptom | Possible cause | Actions |
|------------------------------------|--|--|
| Noise heard from around piston | Worn or damaged piston ring | Replace the piston and piston rings as a set. |
| | Worn or damaged piston | Replace the piston and piston rings as a set. |
| | Worn piston (piston pin hole) | Replace the piston and piston pin as a set. |
| | Worn or damaged piston pin | Replace the piston pin. |
| | Worn or damaged cylinder bore | Replace the cylinder, piston, and piston rings as a set. |
| | Carbon buildup in piston head and combustion chamber | Clean the piston head and combustion chamber. |
| Noise heard from around crankshaft | Worn or damaged crankshaft journal or crank pin | Replace the crankshaft. |
| | Cracked, worn, or damaged balancer shaft | Replace the balancer drive gear and balancer shaft as a set. |
| | Worn or damaged balancer drive gear | Replace the balancer drive gear and balancer shaft as a set. |
| | Worn or damaged big end bearing | Replace the big end bearing. |
| | Worn or damaged crankshaft journal bearing | Replace the crankshaft journal bearing. |
| | Worn or damaged balancer shaft journal bearing | Replace the balancer shaft journal bearing. |

EAM30510

TROUBLESHOOTING OF CLUTCH

Manual clutch

| Symptom | Possible cause | Actions |
|-----------------|----------------------------------|--|
| Clutch slippage | Improperly assembled clutch | Reassemble the clutch. |
| | Improperly adjusted clutch cable | Adjust the clutch lever free play. |
| | Loose clutch spring | Tighten the clutch spring bolts to the specified torque. |
| | Fatigued clutch spring | Replace the clutch springs as a set. |
| | Warped pressure plate | Replace the pressure plate. |
| | Worn friction plate | Replace the friction plates as a set. |
| | Warped or worn clutch plate | Replace the clutch plates as a set. |
| | Incorrect oil level | Adjust the engine oil level to the specified level. |
| | Incorrect oil viscosity (low) | Change to recommended engine oil. |
| | Deteriorated oil | Change to recommended engine oil. |

TROUBLESHOOTING

| Symptom | Possible cause | Actions |
|--------------|---------------------------------------|--|
| Clutch drags | Faulty clutch spring | Replace the clutch springs as a set. |
| | Warped pressure plate | Replace the pressure plate. |
| | Swollen friction plate | Replace the friction plates as a set. |
| | Warped clutch plate | Replace the clutch plates as a set. |
| | Bent pull rod (outer pull type) | Replace the pull rod. |
| | Worn pull rod tooth (outer pull type) | Replace the pull rod and pull lever shaft as a set. |
| | Bent push rod (inner push type) | Replace the push rod. |
| | Damaged or worn clutch boss | Replace the clutch boss. |
| | Seized clutch housing bushing | Replace the clutch housing. |
| | Improperly installed pull lever | Align the match mark on the pull lever before installation. |
| | Incorrect oil level | Adjust the engine oil level to the specified level. |
| | Incorrect oil viscosity (high) | Change to recommended engine oil. |
| | Deteriorated oil | Change to recommended engine oil. |
| Clutch noise | Damaged or worn primary driven gear | Replace the primary drive gear or crankshaft, and the clutch housing as a set. |
| | Loose clutch boss nut | Tighten the clutch boss nut to the specified torque. |
| | Fatigued clutch damper | Replace the clutch housing. |
| | Worn clutch housing bearing | Replace the clutch housing bearing. |
| | Worn pressure plate bearing | Replace the pressure plate bearing. |

TROUBLESHOOTING

EAM30511

TROUBLESHOOTING OF TRANSMISSION

| Symptom | Possible cause | Actions |
|--|---|---|
| Difficult or impossible to shift transmission gear | Clutch drags | Refer to "Clutch drags". |
| | Improperly adjusted shift rod | Adjust the shift rod installation length. |
| | Bent shift shaft | Replace the shift shaft. |
| | Foreign object in a shift drum groove | Remove foreign object from shift drum groove. |
| | Damaged shift drum | Replace the shift drum. |
| | Seized shift fork | Replace the shift fork and shift fork guide bar as a set. |
| | Bent shift fork guide bar | Replace the shift fork guide bar. |
| | Foreign object between transmission gears | Remove foreign object from transmission gears. |
| | Seized transmission gear | Replace the seized gear and the axle as a set. |
| | Improperly assembled transmission | Reassemble the transmission axle assembly. |
| Jumps out of gear | Incorrect shift pedal position | Adjust the shift pedal position. |
| | Improperly returned stopper lever | Replace the stopper lever spring. |
| | Bent or worn shift fork | Replace the shift fork. |
| | Shift drum incorrect axial play | Replace the shift drum. |
| | Worn shift drum groove | Replace the shift drum. |
| | Worn transmission gear dog | Replace the transmission gear. |
| Transmission noise | Damaged or worn transmission gear | Replace the transmission gear. |
| | Worn main axle spline | Replace the main axle. |
| | Worn drive axle spline | Replace the drive axle. |
| | Worn bearing | Replace the bearing. |

TROUBLESHOOTING

EAM30512

TROUBLESHOOTING OF COOLING SYSTEM

| Symptom | Possible cause | Actions |
|---------------------------------|--|---|
| Overheating | Carbon buildup in piston head and combustion chamber | Clean the piston head and combustion chamber. |
| | Clogged engine cooling water passages | Check and clean the engine cooling water passages. |
| | Incorrect oil level | Adjust the oil level to the specified level. |
| | Incorrect oil viscosity | Change to recommended engine oil. |
| | Inferior oil quality | Change to recommended engine oil. |
| | Low coolant level | Add recommended coolant to the specified level. |
| | Damaged or leaking radiator | Replace the radiator. |
| | Faulty radiator cap | Replace the radiator cap. |
| | Clogged radiator fin | Clean the radiator fin. |
| | Bent or damaged radiator fin | Repair the radiator fin or replace the radiator. |
| | Faulty radiator fan motor | Have a Yamaha dealer check the electrical system. |
| | Damaged or faulty water pump | Replace the water pump. |
| | Damaged hoses or pipes | Replace the hose or pipe. |
| | Improperly connected hoses or pipes | Connect the hoses and pipes properly. |
| | Damaged throttle body joint | Replace the throttle body joint. |
| | Loose throttle body joint | Tighten the throttle body joint bolts to the specified torque. |
| | Clogged air filter element | Clean or replace the air filter element. |
| | Brake drags | Check the brake system and repair or replace faulty parts as necessary. |
| Incorrect spark plug gap | Adjust to the specified spark plug gap. | |
| Incorrect spark plug heat range | Replace the spark plug with the one of the specified type. | |
| Faulty ECU | Replace the ECU. | |
| Noise from water pump | Contact between the water pump housing cover and impeller | Disassemble the water pump and replace faulty parts. |
| | Worn water pump housing bearing | Replace the water pump housing bearing. |

TROUBLESHOOTING

EAM30513

TROUBLESHOOTING OF BRAKE

| Symptom | Possible cause | Actions |
|--------------------------------|--|---|
| Poor performance of disc brake | Worn brake pad | Replace the brake pads as a set. |
| | Worn or deflected brake disc | Replace the brake disc. |
| | Air in hydraulic brake system | Bleed the hydraulic brake system. |
| | Brake fluid leakage | Check the hydraulic brake system and repair or replace faulty parts as necessary. |
| | Incorrect brake fluid level (low) | Add brake fluid to the specified level. |
| | Stuck brake caliper piston | Replace the caliper piston seal. |
| | Stuck brake caliper and slide pin | Lubricate the caliper slide pin. |
| | Loose union bolt | Tighten the union bolt to the specified torque. |
| | Damaged brake hose and brake pipe | Replace the brake hose and brake pipe. |
| | Oil or grease on the brake disc or brake pad | Clean the brake disc or brake pad. |
| | Insufficient lubrication of brake lever or brake pedal pivot | Lubricate the brake lever or brake pedal pivot. |

EAM30514

TROUBLESHOOTING OF SUSPENSION

| Symptom | Possible cause | Actions |
|--------------------|--|------------------------------------|
| Front fork is hard | Bent or damaged inner tube | Replace the inner tube. |
| | Bent or damaged outer tube | Replace the outer tube. |
| | Damaged or worn slide metal | Replace the slide metal. |
| | Bent or damaged damper rod | Replace the damper rod. |
| | Bent wheel axle | Replace the wheel axle. |
| | Incorrect oil viscosity (high) | Change to recommended fork oil. |
| | Incorrect oil level (high) | Adjust to the specified oil level. |
| | Improperly adjusted spring preload (hard) | Adjust the spring preload. |
| | Improperly adjusted rebound damping (hard) | Adjust the rebound damping. |
| | Improperly adjusted compression damping (hard) | Adjust the compression damping. |

TROUBLESHOOTING

| Symptom | Possible cause | Actions |
|-----------------------------|--|---|
| Front fork is soft | Fatigued or broken fork spring | Replace the fork spring. |
| | Incorrect oil viscosity (low) | Change to recommended fork oil. |
| | Incorrect oil level (low) | Adjust to the specified oil level. |
| | Improperly adjusted spring preload (soft) | Adjust the spring preload. |
| | Improperly adjusted rebound damping (soft) | Adjust the rebound damping. |
| | Improperly adjusted compression damping (soft) | Adjust the compression damping. |
| Leaking oil from front fork | Bent, damaged, or corroded inner tube | Replace the inner tube. |
| | Cracked or damaged outer tube | Replace the outer tube. |
| | Improperly installed oil seal | Replace the oil seal. |
| | Damaged oil seal lip | Replace the oil seal. |
| | Incorrect oil level (high) | Adjust to the specified oil level. |
| | Loose damper rod assembly bolt | Tighten the damper rod assembly bolt to the specified torque. |
| | Damaged damper rod assembly bolt copper washer | Replace the damper rod assembly bolt copper washer. |
| | Cracked or damaged cap bolt O-ring | Replace the cap bolt O-ring. |
| Rear suspension is hard | Bent or damaged rear shock absorber rod | Replace the rear shock absorber. |
| | Bent swingarm pivot shaft | Replace the swingarm pivot shaft. |
| | Damaged or worn swingarm bearing or bushing | Replace the swingarm bearing or bushing. |
| | Damaged or worn relay arm bearing | Replace the relay arm bearing. |
| | Damaged or worn connecting arm bearing | Replace the connecting arm bearing. |
| | Improperly adjusted rear shock absorber spring preload (hard) | Adjust the spring preload. |
| | Improperly adjusted rear shock absorber rebound damping (hard) | Adjust the rebound damping. |
| | Improperly adjusted rear shock absorber compression damping (hard) | Adjust the compression damping. |

TROUBLESHOOTING

| Symptom | Possible cause | Actions |
|--------------------------------------|--|----------------------------------|
| Rear suspension is soft | Oil leaking from rear shock absorber | Replace the rear shock absorber. |
| | Gas leaking from rear shock absorber | Replace the rear shock absorber. |
| | Fatigued or damaged rear shock absorber spring | Replace the rear shock absorber. |
| | Improperly adjusted rear shock absorber spring preload (soft) | Adjust the spring preload. |
| | Improperly adjusted rear shock absorber rebound damping (soft) | Adjust the rebound damping. |
| | Improperly adjusted rear shock absorber compression damping (soft) | Adjust the compression damping. |
| Oil leaking from rear shock absorber | Bent, damaged, or corroded rear shock absorber rod | Replace the rear shock absorber. |
| | Damaged oil seal lip | Replace the rear shock absorber. |

EAM30515

TROUBLESHOOTING OF STEERING/HANDLING

| Symptom | Possible cause | Actions |
|-----------------------|--|---|
| Handlebar wobble | Loose lower ring nut | Tighten the lower ring nut to the specified torque. |
| | Worn bearing or bearing race | Replace the bearing and bearing race as a set. |
| | Warped front fork | Repair or replace the front fork. |
| | Bent front wheel axle | Replace the front wheel axle. |
| | Incorrect tire pressure | Adjust to the specified tire pressure. |
| | Worn, deformed, or incorrect tire | Replace the tire. |
| Heavy steering | Lower ring nut is tightened too tight. | Tighten the lower ring nut to the specified torque. |
| | Bent lower bracket | Replace the lower bracket. |
| | Broken bearing or bearing race | Replace the bearing and bearing race as a set. |
| | Incorrect tire pressure | Adjust to the specified tire pressure. |
| Front wheel vibration | Loose spoke | Tighten the spoke and adjust the runout. |
| | Damaged or worn wheel bearing | Replace the wheel bearing. |
| | Worn, deformed, or incorrect tire | Replace the tire. |
| | Loose wheel axle or wheel axle nut | Tighten the wheel axle or wheel axle nut to the specified torque. |
| | Loose wheel axle pinch bolt | Tighten the wheel axle pinch bolt to the specified torque. |
| | Incorrect front fork oil level | Adjust to the specified front fork oil level. |

TROUBLESHOOTING

| Symptom | Possible cause | Actions |
|----------------------|---|---|
| Rear wheel vibration | Loose spoke | Tighten the spoke and adjust the runout. |
| | Damaged or worn wheel bearing | Replace the wheel bearing. |
| | Worn, deformed, or incorrect tire | Replace the tire. |
| | Loose wheel axle nut | Tighten the wheel axle nut to the specified torque. |
| | Loose swingarm pivot shaft | Tighten the swingarm pivot shaft to the specified torque. |
| | Bent or damaged swingarm | Replace the swingarm bearing. |
| | Damaged or worn swingarm bearing or bushing | Replace the swingarm bearing or bushing. |

EAM30516

TROUBLESHOOTING OF CHARGING SYSTEM

| Symptom | Possible cause | Actions |
|------------------------|---|---------|
| Battery is not charged | Have a Yamaha dealer check the electrical system. | |

EAM30525

TROUBLESHOOTING OF LIGHTING SYSTEM

| Symptom | Possible cause | Actions |
|------------------------------|---|---------|
| Headlight does not come on | Have a Yamaha dealer check the electrical system. | |
| Tail light does not come on | Have a Yamaha dealer check the electrical system. | |
| Meter light does not come on | Have a Yamaha dealer check the electrical system. | |

EAM30521

TROUBLESHOOTING OF SIGNALING SYSTEM

| Symptom | Possible cause | Actions |
|--|---|---------|
| Indicator lights do not come on properly | Have a Yamaha dealer check the electrical system. | |
| Speedometer fails to operate correctly | Have a Yamaha dealer check the electrical system. | |

SELF-DIAGNOSTIC FUNCTION AND DIAGNOSTIC CODE TABLE

EAM20174

SELF-DIAGNOSTIC FUNCTION AND DIAGNOSTIC CODE TABLE

EAM30497

SELF-DIAGNOSTIC FUNCTION TABLE (FOR FUEL INJECTION SYSTEM)

| Fault code | Item |
|------------|---|
| 12 | Crankshaft position sensor: no normal signals are received from the crankshaft position sensor. |
| 13 | Intake air pressure sensor: open or short circuit detected. |
| 14 | Intake air pressure sensor: hose system malfunction (clogged or detached hose). |
| 15 | Throttle position sensor: open or short circuit detected. |
| 16 | Throttle position sensor: stuck throttle position sensor is detected. |
| 21 | Coolant temperature sensor: open or short circuit detected. |
| 22 | Intake air temperature sensor: open or short circuit detected. |
| 30 | The vehicle has overturned. |
| 33 | Ignition coil: open or short circuit detected in the primary lead of the ignition coil. |
| 39 | Injector: open or short circuit detected. |
| 41 | ECU: built-in lean angle sensor malfunction. |
| 43 | Fuel system voltage: incorrect voltage supplied to the main relay and CCU. |
| 44 | EEPROM fault code number: an error is detected while reading or writing on EEPROM. |
| 46 | Vehicle system power supply: normal voltage is not supplied to the ECU. |
| 50 | ECU: faulty ECU memory. |
| 70 | Engine forcibly stops when the vehicle is left idling for a long period of time. |

SELF-DIAGNOSTIC FUNCTION AND DIAGNOSTIC CODE TABLE

TUNING

| | |
|--|-----|
| CHASSIS | 9-1 |
| SELECTION OF THE SECONDARY REDUCTION RATIO (SPROCKET) | 9-1 |
| DRIVE AND REAR WHEEL SPROCKETS SETTING PARTS | 9-1 |
| TIRE PRESSURE..... | 9-1 |
| FRONT FORK SETTING..... | 9-1 |
| CHANGE IN AMOUNT AND CHARACTERISTICS OF FORK OIL..... | 9-2 |
| SETTING OF SPRING AFTER REPLACEMENT | 9-2 |
| FRONT FORK SETTING PARTS..... | 9-3 |
| REAR SUSPENSION SETTING | 9-3 |
| CHOOSING SET LENGTH | 9-3 |
| SETTING OF SPRING AFTER REPLACEMENT | 9-4 |
| REAR SHOCK ABSORBER SETTING PARTS | 9-4 |
| SUSPENSION SETTING (FRONT FORK)..... | 9-6 |
| SUSPENSION SETTING (REAR SHOCK ABSORBER) | 9-7 |

EAM20119

CHASSIS

EAM30168

SELECTION OF THE SECONDARY REDUCTION RATIO (SPROCKET)

Secondary reduction ratio = Number of rear wheel sprocket teeth/Number of drive sprocket teeth



**Secondary reduction ratio
3.846 (50/13)**

<Requirement for selection of secondary gear reduction ratio>

- It is generally said that the secondary gear ratio should be reduced for a longer straight portion of a speed course and should be increased for a course with many corners. Actually, however, as the speed depends on the ground condition of the day of the race, be sure to run through the circuit to set the machine suitable for the entire course.
- In actuality, it is very difficult to achieve settings suitable for the entire course and some settings may be sacrificed. Thus, the settings should be matched to the portion of the course that has the greatest effect on the race result. In such a case, run through the entire course while making notes of lap times to find the best balance; then, determine the secondary reduction ratio.
- If a course has a long straight portion where a machine can run at maximum speed, the machine is generally set such that it can develop its maximum revolutions toward the end of the straight line, with care taken to avoid the engine over-revving.

TIP

Riding technique varies from rider to rider and the performance of a machine also vary from machine to machine. Therefore, do not imitate other rider's settings from the beginning but choose your own setting according to the level of your riding technique.

EAM30169

DRIVE AND REAR WHEEL SPROCKETS SETTING PARTS

| Part name | Type | Part number |
|--------------------------|------|-------------|
| Drive sprocket "1" (STD) | 13T | 9383E-13233 |

| Part name | Type | Part number |
|-------------------------------|------|--------------|
| Rear wheel sprocket "2" (STD) | 48T | 5GS-25448-50 |
| | 50T | 5TJ-25450-80 |
| | 51T | BAK-25451-00 |
| | 52T | 5TJ-25452-80 |

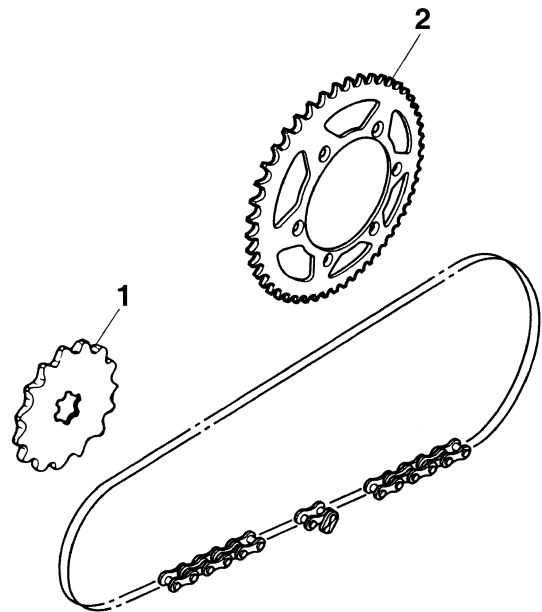

EAM30170

TIRE PRESSURE

Tire pressure should be adjusted to suit the road surface condition of the circuit.



**Standard tire pressure
100 kPa (1.00 kgf/cm², 15 psi)**

- Under a rainy, a muddy, a sandy, or a slippery condition, the tire pressure should be lower for a larger area of contact with the road surface.



**Extent of adjustment
60–80 kPa (0.60–0.80 kgf/cm², 9–12 psi)**

- Under a stony or a hard road condition, the tire pressure should be higher to prevent a flat tire.



**Extent of adjustment
100–120 kPa (1.00–1.20 kgf/cm², 15–18 psi)**

EAM30171

FRONT FORK SETTING

The front fork setting should be made depending

on the rider's feeling of an actual run and the circuit conditions.

The front fork setting includes the following three factors:

1. Setting of air spring characteristics
 - Change the fork oil amount.
2. Setting of spring preload
 - Change the spring.
3. Setting of damping force
 - Change the compression damping force.
 - Change the rebound damping force.

The spring acts on the load and the damping force acts on the cushion travel speed.

EAM30172

CHANGE IN AMOUNT AND CHARACTERISTICS OF FORK OIL

Damping characteristic near the final stroke can be changed by changing the fork oil amount.

EWA19190



WARNING

Adjust the oil amount in 5 cm³ (0.2 US oz, 0.2 Imp.oz) increments or decrements. Too small oil amount causes the front fork to produce a noise at full rebound or the rider to feel some pressure on his hands or body. Alternatively, too large oil amount will cause the air spring characteristics to have a tendency to be stiffer with the consequent deteriorated performance and characteristics. Therefore, adjust the front fork within the specified range.



Recommended oil
 Yamaha Suspension Oil S1
Standard oil amount
 285 cm³ (9.64 US oz, 10.05 Imp.oz)
Extent of adjustment
 260–365 cm³ (8.79–12.34 US oz, 9.17–12.87 Imp.oz)

A

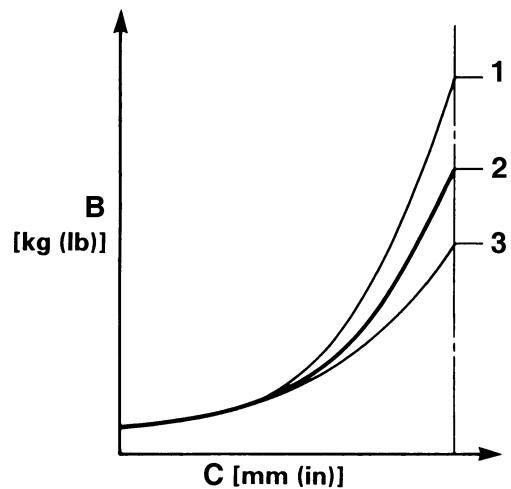

A. Air spring characteristics in relation to oil amount change

B. Load

C. Stroke

1. Max. oil amount

2. Standard oil amount

3. Min. oil amount

EAM30173

SETTING OF SPRING AFTER REPLACEMENT

As the front fork setting can be easily affected by the rear suspension, take care so that the front and the rear are balanced (in position etc.) when setting the front fork.

1. Use of soft spring

- Change the rebound damping force.
Turn out one or two clicks.
- Change the compression damping force.
Turn in one or two clicks.

TIP

Generally a soft spring gives a soft riding feeling. Rebound damping tends to become stronger and the front fork may sink deeply over a series of gaps.

2. Use of stiff spring

- Change the rebound damping force.
Turn in one or two clicks.
- Change the compression damping force.
Turn out one or two clicks.

TIP

Generally a stiff spring gives a stiff riding feeling. Rebound damping tends to become weaker, resulting in lack of a sense of contact with the road surface or in a vibrating handlebar.

EAM30174

FRONT FORK SETTING PARTS

- Front fork spring

| STD Spring rate N/mm | | 4.6 | |
|----------------------|------------------|--------------|-------------------|
| Type | Spring rate N/mm | Part number | I.D. mark (slits) |
| ↑ | 4.1 | B3J-23141-10 | III |
| | 4.2 | B3J-23141-20 | IIII |
| | 4.3 | B3J-23141-30 | IIIIII |
| | 4.4 | B3J-23141-40 | I-I |
| | 4.5 | BR9-23141-20 | I-II |
| | 4.6 | BR9-23141-30 | I-III |
| | 4.7 | BR9-23141-40 | I-IIII |
| | 4.8 | BR9-23141-50 | I-IIIII |
| | 4.9 | BR9-23141-60 | II-II |
| ↓ | 5.0 | BR9-23141-70 | II-III |
| | 5.1 | BR9-23141-80 | II-IIII |
| STIFF | | | |

TIP

The I.D. mark (slits) is proved on the end of the spring.

EAM30175

REAR SUSPENSION SETTING

The rear shock absorber setting should be made depending on the rider's feeling of an actual run and the circuit conditions.

The rear suspension setting includes the following two factors:

1. Setting of spring preload
 - Change the set length of the spring.
 - Change the spring.
2. Setting of damping force
 - Change the rebound damping force.
 - Change the compression damping force.

EAM30176

CHOOSING SET LENGTH

1. Place a stand or a block under the engine to put the rear wheel above the floor, and measure the length "a" between the rear wheel axle center and the rear fender holding bolt.

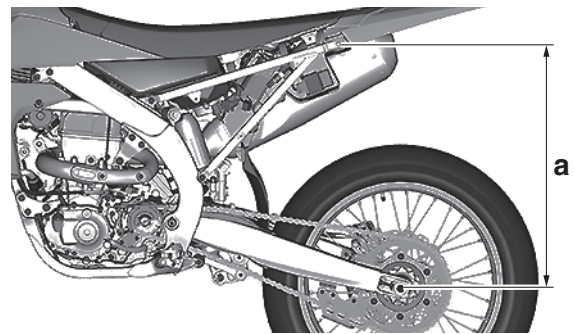

2. Remove the stand or block from the engine and, with a rider astride the seat, measure the sunken length "b" between the rear wheel axle center and the rear fender holding bolt.

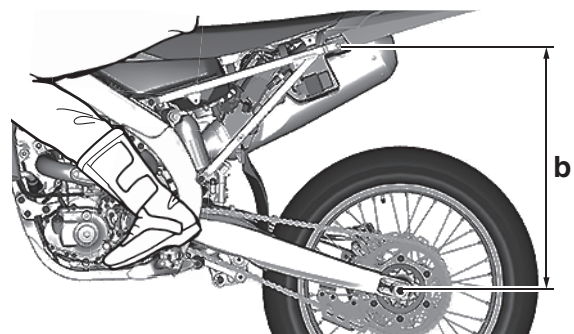

3. Loosen the locknut "1" and make adjustment by turning the adjuster "2" to achieve the standard figure from the subtraction of the length "b" from the length "a".



Standard figure
90–100 mm (3.5–3.9 in)

TIP

- If the machine is new and after it is broken in, the same set length of the spring may change because of the initial fatigue, etc. of the spring. Therefore, be sure to make reevaluation.
- If the standard figure cannot be achieved by adjusting the adjuster and changing the set length, replace the spring with an optional one and make readjustment.

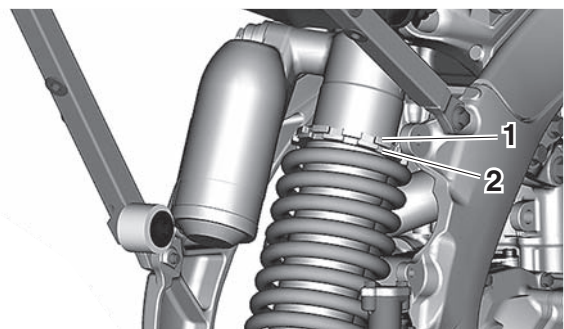

EAM30177

SETTING OF SPRING AFTER REPLACEMENT

After replacement, be sure to adjust the spring to the set length [sunken length 90–100 mm (3.5–3.9 in)] and set it.

1. Use of soft spring
 - Adjust to decrease rebound damping force to compensate for less spring load. Run with the rebound damping force adjuster one or two clicks turned out, and readjust it to suit your preference.
2. Use of stiff spring
 - Adjust to increase rebound damping force to compensate for greater spring load. Run with the rebound damping force adjuster one or two clicks turned in, and readjust it to suit your preference.

TIP

Adjusting the rebound damping force will be followed more or less by a change in the compression damping force. For correction, adjust to decrease compression damping force.

EWA19200

WARNING

When using a rear shock absorber other than currently installed, use the one whose overall length “a” does not exceed the standard as it may result in faulty performance. Never use one whose overall length is greater than standard.

 Length “a” of standard shock
460.5 mm (18.1 in)

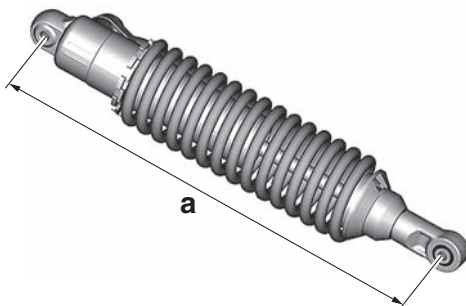

EAM30178

REAR SHOCK ABSORBER SETTING PARTS

- Rear shock spring “1”

| STD Spring rate N/mm | | 56 | |
|-------------------------|--------------------------|--------------------------|-----------|
| Type | Spring rate N/mm | Part number | I.D. mark |
| SOFT ↑ | 48 | BAJ-22212-00 (Blue) | Black |
| | | BAJ-22212-10 (Black) | Gray |
| | | BAJ-22212-30 (Silver) | Black |
| | 50 | B3J-22212-00 (Blue) | Green |
| | | B3J-22212-10 (Black) | |
| | 52 | BR9-22212-00 (Blue) | Yellow |
| | | BR9-22212-50 (Black) | |
| | 54 | BR9-22212-10 (Blue) | Pink |
| | | BR9-22212-60 (Black) | |
| | 56 | BR9-22212-20 (Blue) | White |
| | | BR9-22212-70 (Black) | |
| | | BR9-22212-A0 (Silver) | |
| 58 | BR9-22212-30 (Blue) | Silver | |
| | BR9-22212-80 (Black) | | |
| | BR9-22212-B0 (Silver) | | |
| 60 | BR9-22212-40 (Blue) | Brown | |
| | BR9-22212-90 (Black) | | |
| STIFF ↓ | | | |

TIP

- The I.D. mark “a” is marked at the end of the spring.
- Spring specification varies according to the color of I.D. marks.

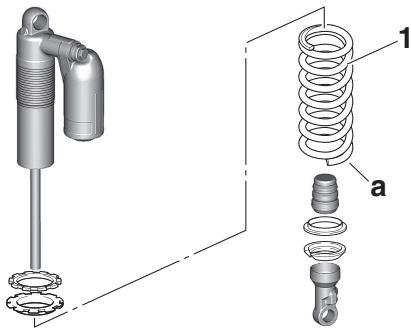

- Spring preload adjusting positions



Spring preload adjusting positions

Minimum

Position in which the spring is turned in 1.5 mm (0.06 in) from its free length.

Standard

Position in which the spring is turned in 10.0 mm (0.39 in) from its free length.

Maximum

Position in which the spring is turned in 18.0 mm (0.71 in) from its free length.

TIP

For the spring preload adjustment, refer to “ADJUSTING THE REAR SHOCK ABSORBER ASSEMBLY” on page 3-26.

EAM30179

SUSPENSION SETTING (FRONT FORK)

TIP

- If any of the following symptoms is experienced with the standard position as the base, make resetting by reference to the adjustment procedure given in the same chart.
- Before any change, set the rear shock absorber sunken length to the standard figure 90–100 mm (3.5–3.9 in).

| Symptom | Section | | | | Check | Adjust |
|---------------------------------------|---------|-----------|------------|-----------|--|--|
| | Jump | Large gap | Medium gap | Small gap | | |
| Stiff over entire range | √ | √ | √ | | Compression damping force Oil amount Spring | Turn adjuster counterclockwise (about 2 clicks) to decrease damping. Decrease oil amount by about 5–10 cm ³ (0.2–0.3 US oz, 0.2–0.4 Imp.oz). Replace with soft spring. |
| Unsmooth movement over entire range | √ | √ | √ | √ | Outer tube Inner tube Slide metal Piston metal Lower bracket tightening torque | Check for any bends, dents, other noticeable scars, etc. If any, replace affected parts. Replace with a new one for extended use. Replace with a new one for extended use. Retighten to specified torque. |
| Poor initial movement | | | | √ | Rebound damping force Oil seals | Turn adjuster counterclockwise (about 2 clicks) to decrease damping. Apply grease in oil seal wall. |
| Soft over entire range, bottoming out | √ | √ | | | Compression damping force Oil amount Spring | Turn adjuster clockwise (about 2 clicks) to increase damping. Increase oil amount by about 5–10 cm ³ (0.2–0.3 US oz, 0.2–0.4 Imp.oz). Replace with stiff spring. |
| Stiff toward stroke end | √ | | | | Oil amount | Decrease oil amount by about 5 cm ³ (0.2 US oz, 0.2 Imp.oz). |
| Soft toward stroke end, bottoming out | √ | | | | Oil amount | Increase oil amount by about 5 cm ³ (0.2 US oz, 0.2 Imp.oz). |
| Stiff initial movement | √ | √ | √ | √ | Compression damping force | Turn adjuster counterclockwise (about 2 clicks) to decrease damping. |

| Symptom | Section | | | | Check | Adjust |
|---|---------|-----------|------------|-----------|---|---|
| | Jump | Large gap | Medium gap | Small gap | | |
| Low front, tending to lower front posture | | | √ | √ | Compression damping force Rebound damping force Balance with rear end Oil amount | Turn adjuster clockwise (about 2 clicks) to increase damping. Turn adjuster counterclockwise (about 2 clicks) to decrease damping. Set sunken length for 95–100 mm (3.7–3.9 in) when one passenger is astride seat (lower rear posture). Increase oil amount by about 5 cm ³ (0.2 US oz, 0.2 Imp.oz). |
| “Obtrusive” front, tending to upper front posture | | | √ | √ | Compression damping force Balance with rear end Spring Oil amount | Turn adjuster counterclockwise (about 2 clicks) to decrease damping. Set sunken length for 90–95 mm (3.5–3.7 in) when one passenger is astride seat (upper rear posture). Replace with soft spring. Decrease oil amount by about 5–10 cm ³ (0.2–0.3 US oz, 0.2–0.4 Imp.oz). |

EAM30180

SUSPENSION SETTING (REAR SHOCK ABSORBER)

TIP

- If any of the following symptoms is experienced with the standard position as the base, make resetting by reference to the adjustment procedure given in the same chart.
- Adjust the rebound damping in 2-click increments or decrements.
- Adjust the low compression damping in 1-click increments or decrements.
- Adjust the high compression damping in 1/6 turn increments or decrements.

| Symptom | Section | | | | Check | Adjust |
|------------------------|---------|-----------|------------|-----------|--|---|
| | Jump | Large gap | Medium gap | Small gap | | |
| Stiff, tending to sink | | | √ | √ | Rebound damping force Spring set length | Turn adjuster counterclockwise (about 2 clicks) to decrease damping. Set sunken length for 90–100 mm (3.5–3.9 in) when one passenger is astride seat. |
| Spongy and unstable | | | √ | √ | Rebound damping force Low compression damping Spring | Turn adjuster clockwise (about 2 clicks) to increase damping. Turn adjuster clockwise (about 1 click) to increase damping. Replace with stiff spring. |

CHASSIS

| Symptom | Section | | | | Check | Adjust |
|--------------------|---------|-----------|------------|-----------|---|--|
| | Jump | Large gap | Medium gap | Small gap | | |
| Heavy and dragging | | | √ | √ | Rebound damping force Spring | Turn adjuster counterclockwise (about 2 clicks) to decrease damping. Replace with soft spring. |
| Poor road gripping | | | | √ | Rebound damping force Low compression damping High compression damping Spring set length Spring | Turn adjuster counterclockwise (about 2 clicks) to decrease damping. Turn adjuster clockwise (about 1 click) to increase damping. Turn adjuster clockwise (about 1/6 turn) to increase damping. Set sunken length for 90–100 mm (3.5–3.9 in) when one passenger is astride seat. Replace with soft spring. |
| Bottoming out | √ | √ | | | High compression damping Spring set length Spring | Turn adjuster clockwise (about 1/6 turn) to increase damping. Set sunken length for 90–100 mm (3.5–3.9 in) when one passenger is astride seat. Replace with stiff spring. |
| Bouncing | √ | √ | | | Rebound damping force Spring | Turn adjuster clockwise (about 2 clicks) to increase damping. Replace with soft spring. |
| Stiff travel | √ | √ | | | High compression damping Spring set length Spring | Turn adjuster counterclockwise (about 1/6 turn) to decrease damping. Set sunken length for 90–100 mm (3.5–3.9 in) when one passenger is astride seat. Replace with soft spring. |

WIRING DIAGRAM**WR450F/WR450FN 2022**

1. Crankshaft position sensor
2. AC magneto
3. Rectifier/regulator
4. Joint connector
5. Headlight relay
6. Main relay
7. Engine ground
8. Battery
9. Frame ground
10. Main fuse
11. Starter relay
12. Starter motor
13. Diode 3
14. Diode 5
15. CCU (Communication Control Unit) (Except for Canada)
16. Resistor
17. Diode 2
18. Yamaha diagnostic tool coupler
19. ECU (Engine Control Unit)
20. Ignition coil
21. Spark plug
22. Fuel injector
23. Fuel sender
24. Fuel pump
25. Radiator fan motor
26. Radiator fan motor fuse
27. Radiator fan motor relay
28. Intake air temperature sensor
29. Coolant temperature sensor
30. Throttle position sensor
31. Intake air pressure sensor
32. Speed sensor
33. Engine stop switch
34. Gear position switch
35. Mode switch (Except for Canada)
36. Diode 1
37. Starting circuit cut-off relay
38. Clutch switch
39. Start switch
40. Diode 4
41. Taillight
42. Multi-function display
43. Headlight

- A. Battery sub-lead
- B. Wire harness
- C. Ignition coil sub-lead
- D. CCU sub-lead (Except for Canada)

COLOR CODE

| | |
|------|--------------|
| B | Black |
| Br | Brown |
| DI | Dark blue |
| G | Green |
| Gy | Gray |
| L | Blue |
| Lg | Light green |
| O | Orange |
| P | Pink |
| R | Red |
| Sb | Sky blue |
| W | White |
| Y | Yellow |
| B/L | Black/Blue |
| B/O | Black/Orange |
| B/R | Black/Red |
| B/W | Black/White |
| B/Y | Black/Yellow |
| Br/W | Brown/White |
| G/B | Green/Black |
| G/W | Green/White |
| G/Y | Green/Yellow |
| L/B | Blue/Black |
| L/G | Blue/Green |
| L/R | Blue/Red |
| L/W | Blue/White |
| P/B | Pink/Black |
| P/L | Pink/Blue |
| R/B | Red/Black |
| R/L | Red/Blue |
| R/W | Red/White |
| R/Y | Red/Yellow |
| W/B | White/Black |
| W/G | White/Green |
| W/L | White/Blue |
| Y/B | Yellow/Black |
| Y/G | Yellow/Green |
| Y/W | Yellow/White |



PRINTED IN JAPAN
(E)

Original instructions
Notice originale
Originalbetriebsanleitung
Istruzioni originali
Manual original



PRINTED IN JAPAN
2021.07-0.6×1 
(E, F, G, H, S)

**WR450F/WR450FN 2022
WIRING DIAGRAM**

**WR450F/WR450FN 2022
SCHEMA DE CÂBLAGE**

**WR450F/WR450FN 2022
SCHALTPLAN**

**WR450F/WR450FN 2022
SCHEMA ELETTRICO**

**WR450F/WR450FN 2022
DIAGRAMA ELÉCTRICO**

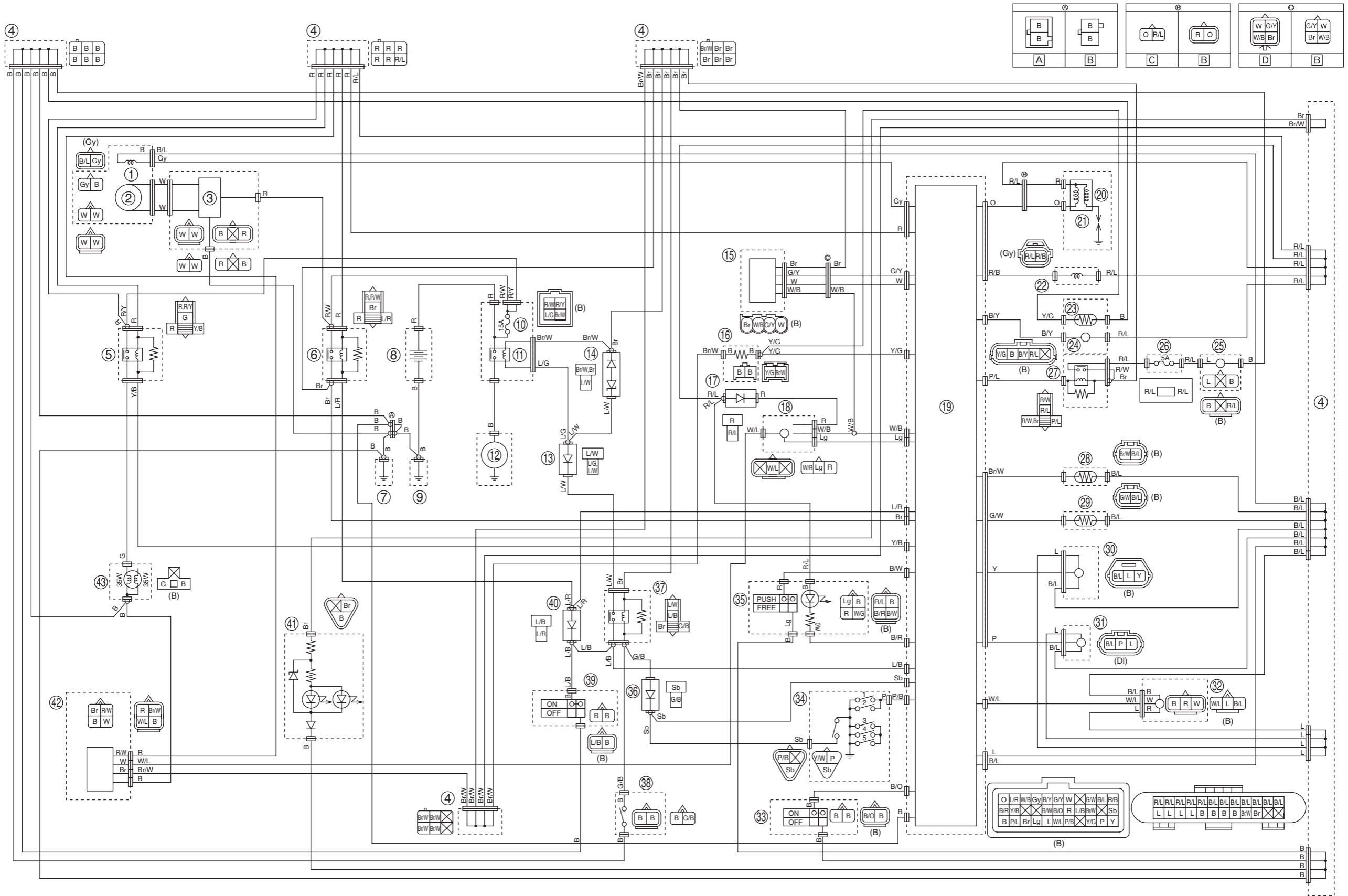

WR450F/WR450FN 2022
WIRING DIAGRAM

WR450F/WR450FN 2022
SCHEMA DE CÂBLAGE

WR450F/WR450FN 2022
SCHALTPLAN

WR450F/WR450FN 2022
SCHEMA ELETTRICO

WR450F/WR450FN 2022
DIAGRAMA ELÉCTRICO

